

Compact Wireless M-Bus Radio Module

868 MHz SRD Band

Key Features

- Low-cost Wireless M-Bus radio module (868 MHz SRD Band)
- Embedded Wireless M-Bus according to EN13757-4:2005 standard
- Range* up to 700 m (line of sight)
- Small form factor: 17 x 27 x 4 mm
- Optimized for battery use
- Easy switching between operating modes S1, S1m, S2, T1, T2, R2
- Communication and configuration via UART/SPI Interface
- Supports AES128 data encryption
- Conforms with EU R&TTE 1999/5/EC directive
- Available on Tape & Reel for SMD mounting

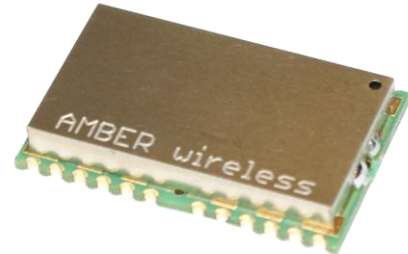

Description

The Wireless M-Bus standard (EN13757-4:2005) specifies the communication between water, gas, heat and electricity meters and concentrators. The standard comprises various operating modes (S, T and R) to meet the requirements of one-way and two-way data communication in stationary and mobile systems.

The AMB8425-M is an all embedded low-cost wireless M-Bus radio module, which operates in 12 channels in the 868 MHz frequency band. The integrated protocol controls the entire data communication. Data packets are built and transmitted according to EN13757-4:2005 specification. Configuration of parameters is handled via the UART interface. The module automatically adds the Manufacturer ID and the Address based on parameters configured in the radio module. Measured field strength (RSSI value) offers the option of enhancing quality of the radio link.

The customised application layer can be fully integrated in the radio module, thus eliminating the need for an external host microcontroller. The radio module supports the AES-128 encryption standard. A very low-power mode ensures long battery lifetime.

The module is pre-certified for operation under the European radio regulations for license-free use. Due to its outstanding RF characteristics the module achieves a range* of up to 700 metres line of sight.

The AMB8425-M is a surface-mounted module and is available on Tape & Reel for volume production.

Interfaces

The AMB8425-M is connected to a host system via an UART interface with data rates of up to 115.2 kbps. Alternatively, a SPI interface is offered (in preparation).

When using appropriate firmware, the module is also suitable for autonomously recording digital or analogue signals. Other pins can be used for data flow control and to switch between operating modes.

Range of Applications

The radio module is designed for automatic meter reading applications for wireless data transmission according to the Wireless M-Bus specification (EN13757-4:2005). The radio module is designed to be integrated in meters, concentrators and mobile metering devices. Other applications are conceivable. Its compact dimensions and low-power consumption make the radio module ideal for battery-powered devices.

Dimensions & Pin Assignment

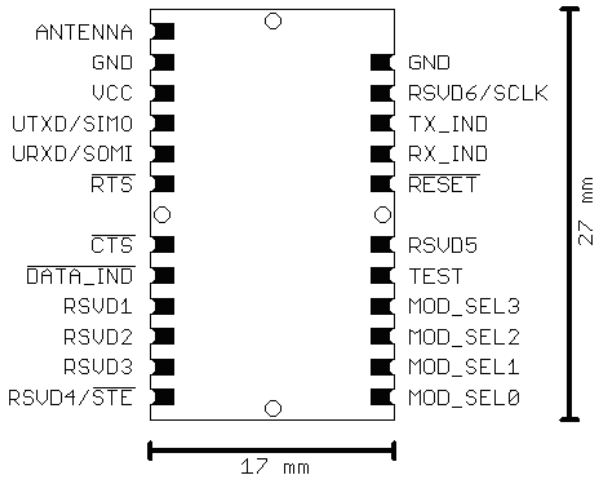

Pad Name	Description
ANTENNA	Antenna port
GND	Ground
VCC	Positive supply voltage
UTXD, URXD	UART transmit, UART receive
SIMO	Slave In Master Out (SPI in preparation)
SOMI	Slave Out Master In (SPI in preparation)
SCLK	SPI clock (SPI in preparation)
/STE	Slave Transmit Enable (SPI in preparation)
/RESET	Reset signal
TX_IND	Signals radio transmission
RX_IND	Signals radio reception
MOD_SELx	wM-Bus mode preselect
/RTS, /CTS	Hardware handshake
/DATA_IND	Signals incoming data
RSVDx	Reserved for future use
TEST	Used for programming purposes

Specifications

Performance	Range*	Up to 700 metres (depending on operating mode and antenna used)
	RF data rate	2.4 / 16.384 / 66.6 kbps (according to EN 13757-4:2005)
	Interface data rate	Up to 115.2 kbps (UART)
	Output power	Up to 11 dBm (50 Ω)
	RF sensitivity	S: typ. -103 dBm T: typ. -100 dBm R: typ. -107 dBm
General	Power supply voltage	2.2 – 3.6 V
	Power consumption	- TX: typ. 38 mA - RX: typ. 24 mA - Low Power: typ. < 0.3 μA
	Dimensions	17 x 27 x 4 mm
	Operating temperature	-30 to +85 °C
	Weight	approx. 3 g
	Antenna	External antenna port (50 Ω)
RF technology	Frequency range	863.03 - 868.95 MHz
	Channel spacing	868.03 MHz + k • 0.06 MHz k=[0,9] 868.30 MHz 868.95 MHz
	Modulation	2-FSK
Conformity	Europe	EN 300 220, EN 301 489, EN 60950, EN 50371

* Range stated is calculated assuming line-of-sight. Actual range will vary based upon specific board integration, antenna selection and environmental conditions.

Related Products

- AMB8426-M-EV Evaluation-Kit

Ordering information

Part No.	Description
AMB8426-M	Wireless M-Bus Radio Module
AMB8426-M-TR	Wireless M-Bus Radio Module, Type & Reel

Contact

AMBER wireless GmbH
 Albin-Koebis-Strasse 18
 51147 Cologne, Germany
 Tel.: +49 2203 98019 0
 Fax: +49 2203 98019 25
 E-mail: info@amber-wireless.de
 Internet: www.amber-wireless.de