

Ultra-stable, high precision (ppm class) fluxgate technology DM Series current transducer for non-intrusive, isolated DC and AC current measurement up to 1320A



**Features**

- Ø45mm aperture
- 15 ppm linearity,
- 10 ppm offset
- 10V output
- Fluxgate, closed loop compensated technology with crystal driven excitation frequency for increased stability
- Industry standard DSUB 9 pin connection
- Full aluminum body for superior EMI shielding and extended operating temperature range

**Applications:**

- Power measurement and power analysis
- Stable power supplies
- MPS for particles accelerators
- Gradient amplifiers for MRI devices
- Precision drives
- Batteries testing and evaluation systems
- Current calibration purposes

Specification highlights	Symbol	Unit	Min	Typ.	Max
Nominal primary AC current	$I_{PN AC}$	Arms			850
Nominal primary DC current	$I_{PN DC}$	A	-1200		1200
Nominal output voltage	$V_{out}$	V	-10		10
Measuring range	$I_{PM}$	A	-1320		1320
Primary / secondary ratio		V/kA	8.3333		8.3333
Linearity error (Best fit)	$\epsilon_L$	ppm	-15		15
Offset Voltage (including earth field)	$V_{OE}$	ppm	-10		10
Ratio error	$\epsilon_C$	ppm	-10		10
DC-10Hz Overall accuracy @25°C (=V <sub>OE</sub> + $\epsilon_L$ + I <sub>OE</sub> )	acc $\epsilon$	ppm	-35		35
AC Maximum gain error 10Hz to 1kHz					100ppm(0.01%)
Bandwidth (3dB)	$f_{3dB}$	kHz	300		
Operating temperature range	$T_a$	°C	-40		65
Power supply voltages	$U_c$	V	±14.25		±15.75

All ppm (or %) values refer to nominal current

**Electrical specifications at Ta=23°C, supply voltage = ± 15V unless otherwise stated**

Parameter	Symbol	Unit	Min	Typ.	Max	Comment
Nominal primary AC current	$I_{PN AC}$	Arms			850	Refer to fig. 2 for derating
Nominal primary DC current	$I_{PN DC}$	A	-1200		1200	
Measuring range	$I_{PM}$	A	-1320		1320	Refer to fig. 2 for derating
Overload capacity	$\hat{I}_{OL}$	A			1500	Non-measured, 100ms
Nominal voltage output	$V_O$	V	-10		10	At nominal primary DC current
Primary / secondary ratio		V/kA	8.3333		8.3333	
Linearity error	$\epsilon_L$	ppm	-15		15	ppm refers to nominal current
Bandwidth (3dB)	$f_{3dB}$	kHz	300			Small signal, graphs figure 3
Response time to a step current IPN	$tr@90\%$	$\mu s$		1		$di/dt = 100A/\mu s$
Amplitude error	$\epsilon_G$	%			0.01	refers to nominal current
10Hz–3kHz					1.00	
3kHz-50kHz					20.00	
Amplitude error	$\epsilon_G$	%			0.01	refers to nominal current
10Hz–3kHz					1.00	
3kHz-50kHz					20.00	
Phase shift	$\theta$	°			0.50	
10Hz–3kHz					8.00	
3kHz-50kHz					60.00	
Phase shift	$\theta$	°			0.50	
10Hz–3kHz					8.00	
3kHz-50kHz					60.00	
Noise	noise	ppm rms			0.15	refers to nominal current
0 - 100Hz					0.2	
0 - 1kHz					0.3	
0 - 10kHz					2	
Noise	noise	ppm p-p			0.8	refers to nominal current
0 - 100Hz					1	
0 - 1kHz					1.7	
0 - 10kHz					8	
Noise	noise	ppm p-p			0.8	refers to nominal current
0 - 100Hz					1	
0 - 1kHz					1.7	
0 - 10kHz					8	
Fluxgate excitation frequency	$f_{Exc}$	kHz		31.25		
Power supply voltages	$U_c$	V	±14.25		±15.75	
Positive current consumption	$I_{ps}$	mA	135	140	145	Add $V_o \cdot 0.08$ (A)
Negative current consumption	$I_{ns}$	mA	120	130	135	Add $V_o \cdot 0.08$ (A)
Operating temperature range	$T_a$	°C	-40		65	
<b>Offset error</b>						
Initial	$V_{OE}$	ppm	-10		10	ppm refers to nominal DC current
Versus temperature	$TC_{VOE}$	ppm/K	-0.1		0.1	ppm refers to nominal DC current
Versus time	$V_{OE}/time$	ppm/month	-0.3		0.3	ppm refers to nominal DC current
Versus supply voltage		ppm/V	-0.1		0.1	ppm refers to nominal DC current
<b>Ratio Error</b>						
Initial @23°C	$\epsilon_C$	ppm	-10		10	ppm refers to primary current
Versus temperature	$TC\epsilon_C$	ppm/K	-1		1	ppm refers to primary current
Versus time	$\epsilon_C/time$	ppm/month	-3		3	ppm refers to primary current

**Frequency and ambient temperature derating (Fig. 2)**

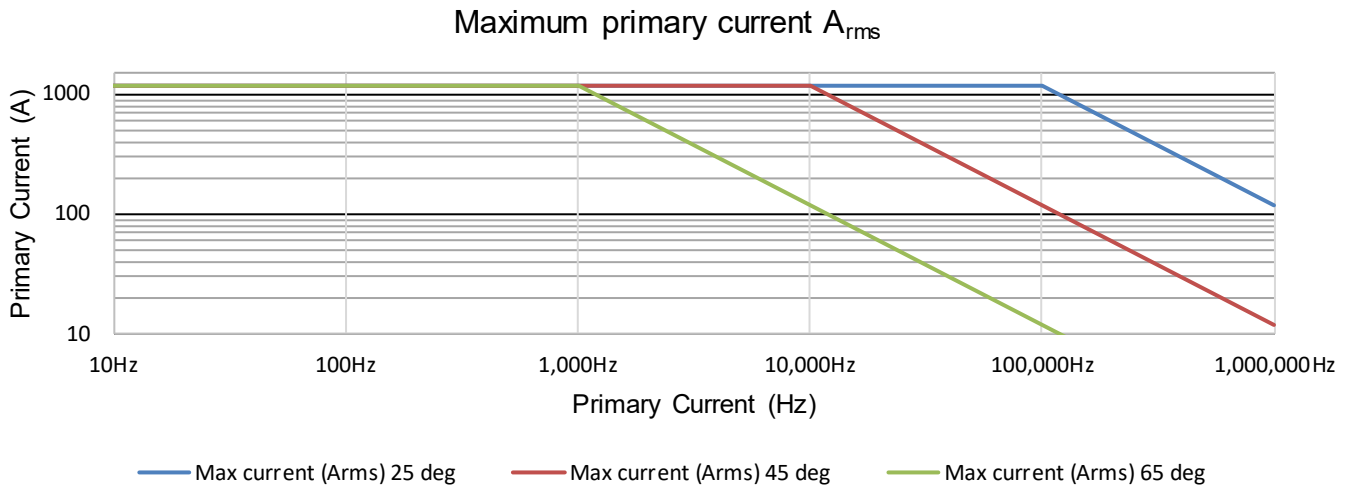

**Frequency characteristics (Fig. 3)**

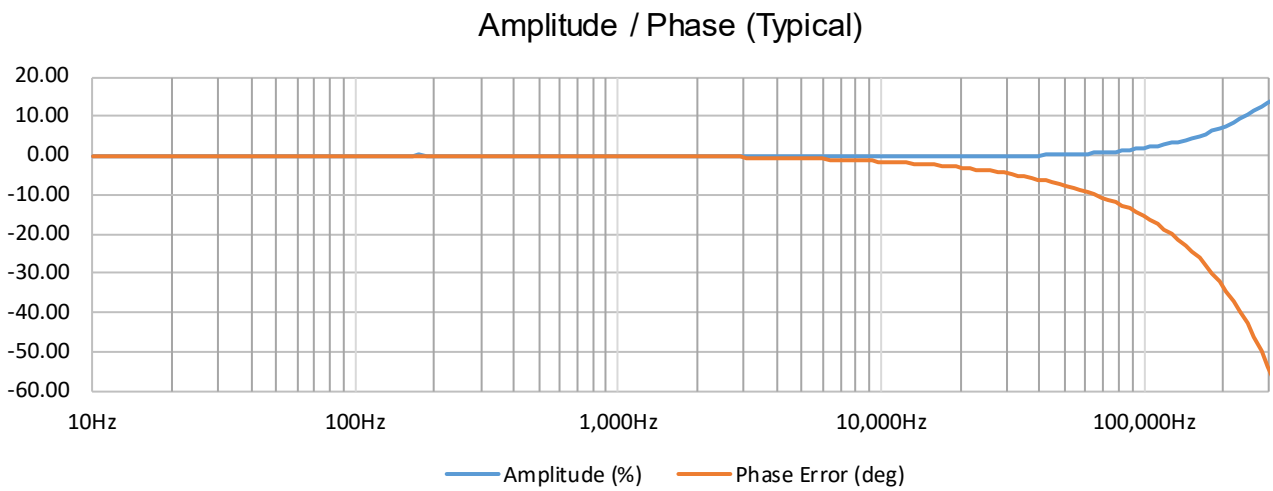

**Isolation specifications**

Parameter	Unit	Value
Clearance	mm	12
Creepage distance	mm	12
Comparative tracking index (CTI)		> 600
Rms voltage for AC isolation test, 50/60 Hz, 1 min - Between primary and (secondary and shield) - Between secondary and shield	kV	5.7 0.2
Impulse withstand voltage (1.2/50µs)	kV	10.4
Continous working voltage with uninsulated wire <ul style="list-style-type: none"> <li>• Non mains</li> <li>• CAT II (DC and rms)</li> <li>• CAT III (DC and rms)</li> </ul> Insulated wire <ul style="list-style-type: none"> <li>• Non mains</li> <li>• CAT II (DC and rms)</li> <li>• CAT III (DC and rms)</li> </ul>	V	1000 600 300  2000 1000 1000
Transient voltage with uninsulated wire <ul style="list-style-type: none"> <li>• Non mains</li> <li>• CAT II</li> <li>• CAT III</li> </ul> Insulated wire <ul style="list-style-type: none"> <li>• Non mains</li> <li>• CAT II</li> <li>• CAT III</li> </ul>	V	4500 6000 6000  6000 6000 8000

**Caution:** Do not connect the transducer to signals or use for measurements within Measurement Category IV, or for measurements on MAINS circuits or on circuits derived from Overvoltage Category IV which may have transient overvoltages above what the product can withstand. The product must not be connected to circuits that have a maximum voltage above the continuous working voltage, relative to earth or to other channels, or this could damage and defeat the insulation. The product can only withstand transients up to the transient overvoltage rating without breakdown or damage to the insulation. An analysis of the working voltages, loop impedances, temporary overvoltages, and transient overvoltages in the system must be conducted prior to making measurements.



**Caution:** When using insulated wires all wiring must be insulated for the highest voltage used.



**Absolute maximum ratings**

Parameter	Unit	Max	Comment
Primary	kA	4.5	Maximum 100ms
Power supply	V	±16.5	

## Environmental, safety and mechanical specifications

Parameter	Unit	Min	Typ	Max	Comment
Altitude	m			2000	
Usage					Designed for indoor use
Transient voltages					Up to overvoltage category III
Poution Degree				2	
Ambient operating temperature range	°C	-40		65	
Storage temperature range	°C	-40		65	
Relative humidity	%	20		80	Non-condensing
Mass	kg		2.0		
Connections	DSUB9 male and BNC connector				
Standards	IEC61010-2-30, IEC61326-1 EMC and EC61010-1:2010 3rd Edition				
External devices	External devices connected to current transducers must comply with the standards IEC61010-1, IEC60950 or IEC62368-1 and be energy-limited circuitry				
Cleaning	The transducer should only be cleaned with a damp cloth. No detergent or chemicals should be used.				
Temperature	<p>When multiple primary turns are used or high primary currents are applied the temperature around the transducer will increase, please monitor to ensure that the maximum ratings are not exceeded.</p> <p>It is recommended to have minimum 1mm<sup>2</sup> per ampere in the primary busbar.</p>				

## Advanced Sensor Protection Circuits “ASPC”

Developed to protect the current transducer from typical fault conditions:

- Unit is un-powered and secondary circuit is open or closed
- Unit is powered and secondary circuit is open or interrupted

Both DC and AC primary current up to 100% of nominal value can be applied to the current transducers in the above situations without damage to the electronics.

Please notice that the transducer core can be magnetized in all above cases, leading to a small change in output offset current (less than 10ppm)

## Accessories

- 4-channel power supplies unit for connection up to 4xDM1200 : [DSSIU-4](#)
- 6-channel power supplies unit for connection up to 6xDM1200 : [DSSIU-6](#)
- Transducer cables in 5 lengths (2m - 5m - 10m - 15m - 20m): [DSUB2 - DSUB5 - DSUB10 - DSUB15 - DSUB20](#)
- Transducer cable 3m for connection to end-user's power supply: [Transducer cable for lab PS](#)  
(with access to current output via  $\phi 4$  banana jacks)

Please visit Danisense homepage for relevant datasheets

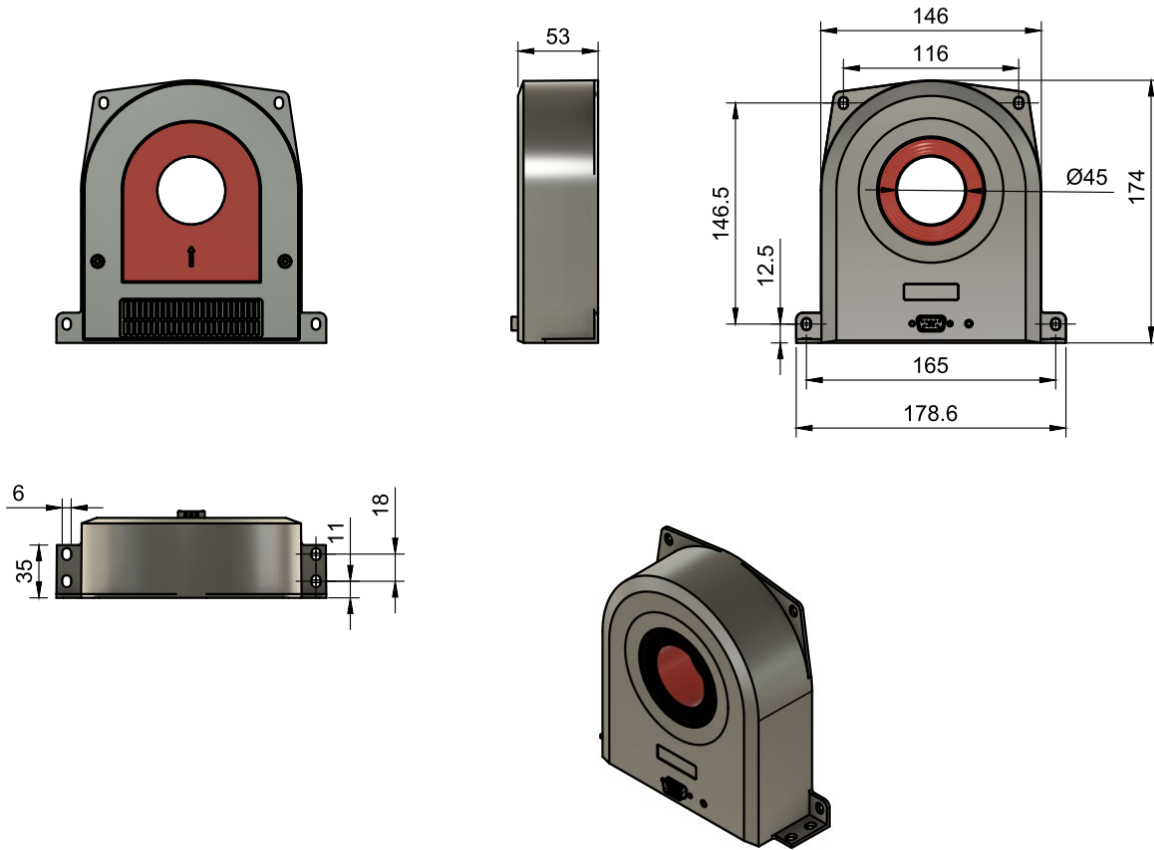

Standard DSUB-9 current output



When sensor is operating in normal condition the status pins are shorted.

Status pin properties.

- Forward direction pin 8 to pin 3
- Maximum forward current 10mA
- Maximum forward voltage 60V
- Maximum reverse voltage 5V

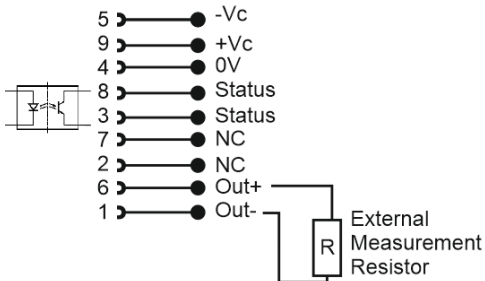

**Positive current direction**

Is identified by an arrow on the transducers red isolation piece in the center

**Mounting instructions**

- Horizontal or vertical mounting
- 4 holes  $\phi 6 \times 11$
- 4 x M5 steel screws / 6N.m

**Intended use:**

The DS1200UB-10V is designed to measure current up to 1320A, and be powered by a DSSIU-4-1U or DSSIU-6-1U.

**Instruction for use:**

1. Do not power up the device before all cables are connected.
2. Only use Danisense cables to ensure correct impedance levels.
3. Place the primary conductor through the aperture of the transducer
4. If the DSSIU-4(6)-1U is intended for desk use, mount the rubber feet which are part of the package.
5. If the DSSIU-4(6)-1U is intended for Rack mounting, use the screw kit for mounting and do not mount the rubber feet.
6. Connect a DSUB cable between DSSIU-4(6)-1U and each sensor
7. Connect a low impedance amperemeter, measuring resistor or power analyzer on the secondary output (4mm red and black connectors)
8. Ensure that no calibration connectors are attached when measuring primary current. Always avoid to create a calibration short circuit, between + and — calibration connection.
9. There is a risk of electrical shock if an uninsulated busbar with high voltages is touching the metal enclosure of the transducer. Please ensure before powering up the system that no primary busbar can touch the metal enclosure.
10. When all connection are secured - connect mains power
11. Apply primary current

**Safety Instructions:**

DO NOT TRY TO DISASSEMBLE THE UNIT.

If the green transducer diode is not operating when the system is powered up, disconnect power and contact Danisense for further instruction.

If the equipment is used in a manner not specified by the manufacturer, the protection provided by the equipment may be impaired.