

DMC Co., Ltd.

**Analog Resistive Touch Screen Controller
TSC-50/IC Product Specification**

Table of Contents

1. Products outline	2
1-1. Scope of Application	2
1-2. Outline	2
1-3. Features	2
1-4. General specification	3
2. Pin layout and representation	4
3. Pin functions	5
4. Initial setting	7
4-1. EEPROM setting	7
4-2. Communication mode setting	7
4-3. Touch screen mode setting	7
4-4. Configuration in USB mode	8
4-5. Panel ID setting (USB mode)	8
5. Data sheet	9
5-1. Absolute maximum rating	9
5-2. Recommended operational conditions	10
5-3. Timing requirement	11
6. Packaging specification	13
6-1. Outline	13
6-2. Notes on storage/handling	13
6-3. Basic packaging	13
6-4. Small group packaging	14
6-5. Tray specification	15
6-6. Product name label specification	15
7. Storage specification	16
7-1. Storage conditions	16
7-2. Baking	16
8. Mounting specification	17
9. Terminal pin specification	18
10. Changes and improvements	18
10-1. Version history	18
11. Warranty	19
11-1. Warranty period	19
11-2. Warranty target	19
11-3. Warranty exceptions	19
12. Notes on use	20
12-1. Overall handling	20
12-2. Others	20

Dimensional Drawing

Circuit Diagram

1. Products outline

1-1. Scope of Application

This specification applies to the TSC-50/IC.

1-2. Outline

TSC-50/IC is an analog touch screen control IC that performs A/D conversion on analog signal for the 4-wire and 5-wire resistive analog touch screen, and transmits coordination data with 10bit resolution to the host in a 9600bps serial (asynchronous) and USB.

At the coordinate detection, internal filtering process provides a stabilized coordinate value. By using the correction function, in addition to the losses that occur in the circuit, display deflection between touch screen input point that occur in each element and indicator cursor can be corrected to adjust the display position.

1-3. Features

- § Two coordinate output modes are provided and selected per application: "Coordinate data mode" where coordinate information is sent with 10bit resolution as it is, and "correction data mode" where read coordinate is converted to the indicator's display coordinate and sent.
- § "Correction data mode" will be available after a correction data is saved into EEPROM that is contained in TSC-50/IC. The correction points can be set up to nine points. Coordinate data can be corrected with the base of correction points. Using this function makes implementation of correction function into the host driver unnecessary.
- § USB has multi-touch screen function enable four simultaneous connections to the host.
- § Two external switch functions are always available in the coordinate (correction) data mode. Two pieces of external switch information are, at the transmission of coordinate data, included in the coordinate data as pen-down/pen-up information. Since in the pen-up mode, pen-up data can be always output to the host, this switch is available as a function switch.
- § At the touch screen input, buzzer and LED outputs are available. Input confirmation via display and sound is available.
- § In the serial communication, when no touch screen input is performed, the state moves to "power-save mode" so that such application can be supported that requests a low power consumption. In USB mode, USB suspend is supported and restored by the external interrupt of touch screen input.
- § Seven types of coordinate output rates are provided and either can be selected per application among seven types: six types from 50 to 150p/s plus one type, a point mode that outputs the coordinate only one time when pen-down is performed.

1-4. General specification

Item		Rating	Notes
Power supply voltage		DC 2.5V to 5.5V	
Operating Current		50mA (TYP) (Sleep mode: 1mA(TYP))	At power supply voltage $V_{DD}=5.0V$ 150p/s, at touch input
Operating Temp		-40 °C to +105 °C (No dew condensation)	
Temperature range at storing		-55 °C to +150 °C (No dew condensation)	
Communication scheme (serial)	Communication scheme	Asynchronous, UART	Each setting is fixed
	Communication rate	9600bps	
	Data length	8bits	
	Stop bit	1bit	
	Parity	None	
Communication scheme (USB)	Transfer rate	USB Specification2.0 Full Speed	
	Transfer mode	Control transfer (command)	
		Interrupt transfer (coordinate)	
Operation frequency		16MHz	Internal CPU 72MHz
Coordinate output rate (point / second)		(1) Point mode (2) 50p/s (3) 50p/s (4) 80p/s (5) 100p/s (6) 150p/s (7) 150p/s	Point Mode: Only when touch screen is input, pen-down ID is sent once. After input ends, no pen-up ID is sent.
Linearity error		±3 LSB	
Input response time		10ms (TYP)	For coordinate mode, 150p/s, Serial mode
Coordinate resolution		10bit (1024×1024)	In the correction data function, resolution follows the setting value
Dimension (mm)		9.0×9.0×1.7	

2. Pin layout and representation

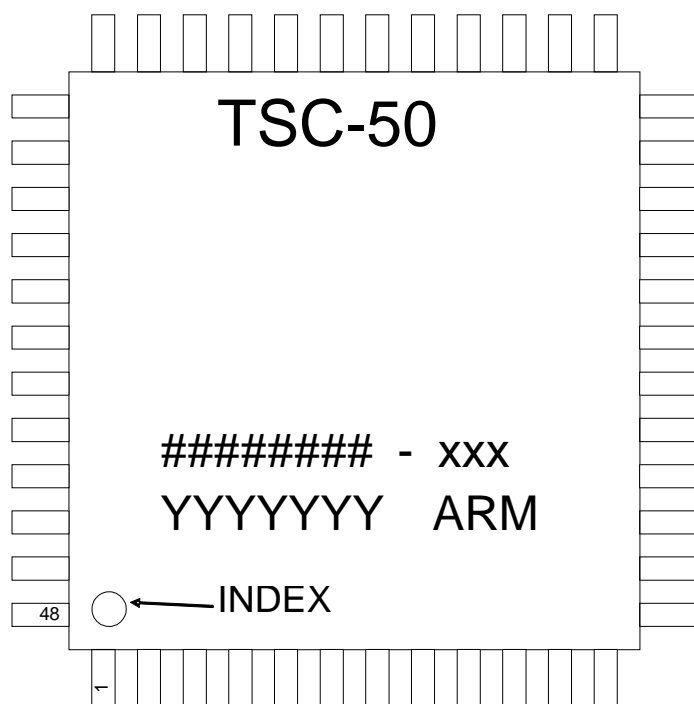

Marking specification

TSC-50	Product number
#####	Lot number
YYYYYYY	DMC Control Number
ARM	ARM CPU

3. Pin functions

Pin number	Pin name	I/O	Functional description
1	AD_YD	I	Touch Screen YD input pin.
2	N.C.	O	Unused pin; Opened.
3	AD_YU	I	Touch Screen YU input pin.
4	nRESET	I	Reset input pin (active L).
5	PANEL_YD	O	Touch screen control pin.
6	AVSS	I	Vss is connected.
7	PANEL_YU	O	Touch screen control pin.
8	PANEL_XR	O	Touch screen control pin.
9	PANEL_XL	O	Touch screen control pin.
10	VBAT	I	VDD is connected.
11	LED0	O	LED output pin; When internal initialization was finished correctly, output L.
12	LED1	O	LED output pin; Touch input, ON=L, OFF=H.
13	LED2	O	LED output pin; When a response for the command is NAK, output L.
14	BEEP	O	BEEP output pin; H output. Output frequency=2.5KHz, Output time=50ms.
15	XT1_OUT	O	Clock output pin; When using external clock, this pin is opened.
16	XT1_IN	I	Clock input pin; When using external clock, clock(16MHz) is input to this pin
17	VSS	I	Vss is connected.
18	LDO_CAP	I	Via capacitance; Vss is connected.
19	PANEL_THOa	O	Pen down detection pin.
20	PANEL_THOb	O	Touch screen control pin. Used only in 5-wire mode. In 4-wire mode, opened.
21	SW0	I	SW0 input pin; H=ON=1, L=OFF=0.
22	SW1	I	SW1 input pin; H=ON=1, L=OFF=0.
23	JP2	I	At the serial mode, connecting to H enables touch operation after boot.
24	JP4	I	In USB mode, Panel ID select pin. Vss is connected in serial mode.
25	ICE_CK	I	Via resistance; VDD is connected.
26	ICE_DAT	I	Via resistance; VDD is connected.
27	PANEL_LL	O	Touch screen control pin.
28	PANEL_UR	O	Touch screen control pin.
29	N.C.	O	Unused pin; Opened.
30	N.C.	O	Unused pin; Opened.
31	VDDIO	I	VDD is connected.
32	USB_VBUS	I	VDD is connected.
33	USB_D-	I/O	In USB mode, D- pin. In Serial mode, Opened.
34	USB_D+	I/O	In USB mode, D+ pin. In Serial mode, Opened.
35	JP5	I	In USB mode, Panel ID select pin. Vss is connected in serial mode.
36	USB_VDD33	I	Via capacitance; Vss is connected.
37	JP7	I	Vss is connected.
38	JP6	I	Touch screen mode setting pin; L=4 wire, H=5-wire
39	UART_RxD	I	In serial mode, data receive pin. In USB mode, Opened.
40	UART_TxD	O	In serial mode, data send pin. In USB mode, Opened.

41	VDD	I	VDD is connected.
42	AVDD	I	VDD is connected.
43	VREF	I	A/D converter reference voltage input pin; VDD is connected.
44	N.C.	O	Unused pin; Opened.
45	JP9	I	EEPROM is set via resistance and VDD or VSS is connected. (L=Used, H=Not used)
46	N.C.	O	Unused pin; Opened.
47	AD_XL	I	Touch Screen XL input pin.
48	AD_XR	I	Touch Screen XR input pin.

4. Initial setting

4-1. EEPROM setting

Depending on that calibration is performed in either TSC-50/IC or host, you can select whether EEPROM is used or not to store the correction data. EEPROM selection can be set via pin number 45, where hardware reset release enables the setting.

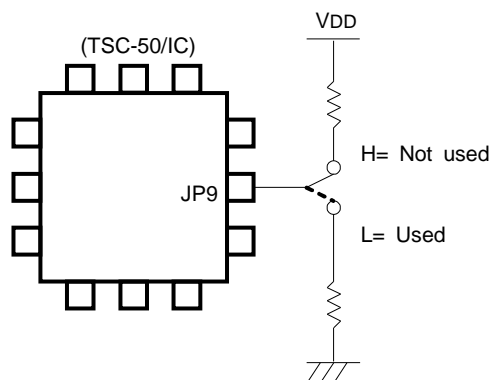

4-2. Communication mode setting

After boot or hardware reset release, either serial or USB communication mode will be determined according to the following conditions.

<Serial Communication>

Serial communication mode will be established if a serial command is received appropriately from the host computer.

<USB Communication>

USB communication mode will be established once USB configuration with the host computer is completed.

*Note

The two types of the communication methods, serial and USB, cannot be used at the same time.

Make sure to use either one of the two communication methods.

Operation would not be guaranteed if both types of the communications are connected at the same time.

4-3. Touch screen mode setting

Touch screen mode setting for 4-wire or 5-wire is performed by setting pin number 38 (JP6) to "H" or "L". When power supply is turned on, or hardware reset is released, pin number 38 is read to turn on in either 4-wire or 5-wire mode.

Mode	Pin number 38 (JP6)
4-wire touch screen	GND
5-wire touch screen	VDD

4-4. Configuration in USB mode

§ Basic configuration

Item	Specification
USB standard	Specification Rev2.0 Full Speed
Power supply	Bus power supply / Self-Power
Device class	Vendor definition
Interrupt (coordinate) transfer interval	1ms
End point buffer size	EP0: 8byte EP1: 5byte (EP0: control transfer, EP1: interrupt transfer)

§ Connection with Host

Coordinate data, correction value or other various output data are all output to the host as a response to IN token. Output coordinate in coordinate data mode and correction data mode is output in the interrupt transfer, while other data is output to the host with control transfer.

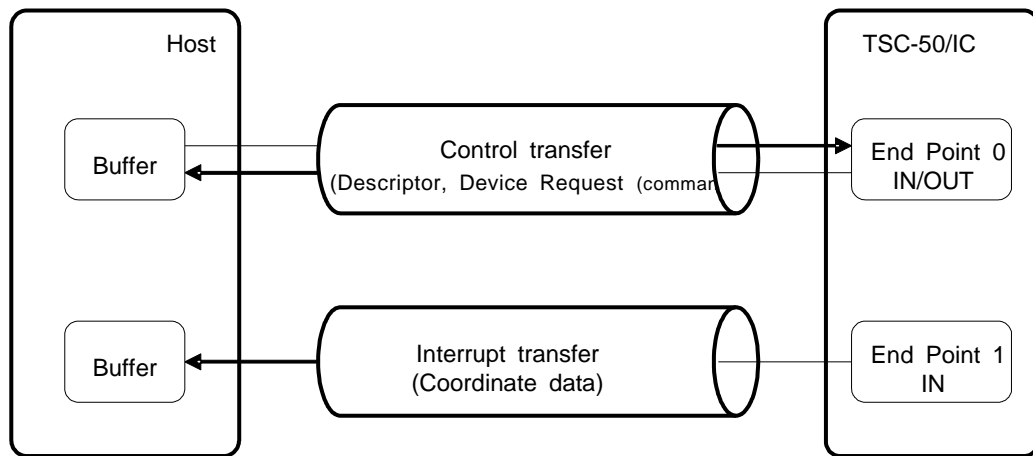

4-5. Panel ID setting (USB mode)

If two (three or four) touch screens to the same host are connected simultaneously, each TSC-50/IC to the host needs panel ID setting. This function is enabled in the USB mode, by setting pin number 24 (JP4) and pin number 35 (JP5) to "H" or "L". Setting is enabled when hardware is reset, where Device Descriptor's iProduct is set to "0" or "1" and this value is identified by the host as panel ID.

JP4	JP5	iProduct	Panel ID
L	L	00h	0
H	L	01h	1
L	H	02h	2
H	H	03h	3

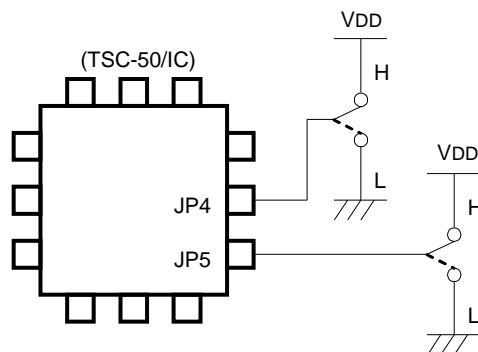

5. Data sheet

5-1. Absolute maximum rating

Item	Symbol	Ratings		Unit	Description
		Minimum	Maximum		
Power supply voltage	V _{DD}	-0.3	7.0	V	
Input voltage	V _I	V _{SS} -0.3	V _{CC} +0.3	V	
Maximum Current into V _{DD}	I _{DD}		120	mA	
Maximum Current out of V _{SS}	I _{SS}		120	mA	
Operation temperature	T _{OPR}	-40	+105	°C	
Storage temperature	T _{STG}	-55	+150	°C	

5-2. Recommended operational conditions

Item	Symbol	Limits			Unit	Description
		Minimum	Standard	Maximum		
Power supply voltage	VDD	2.5		5.5	V	
Analog reference voltage	AVDD		VDD		V	
Power supply voltage (GND)	Vss	-0.3	0	0.3	V	
Analog reference voltage (GND)	AVss	-0.3	0	0.3	V	
“L” input voltage (Pin number 21-26, 35, 37-39, 45)	V _{IL1}	-0.3		0.8	V	VDD=4.5V
		-0.3		0.6		VDD=2.5V
“H” input voltage (Pin number 21-26, 35, 37-39, 45)	V _{IH1}	2.0		VDD+0.3	V	VDD=5.5V
		1.5		VDD+0.3		VDD=3.0V
“L” output voltage (Pin number 5,7-9,11-14,19, 20,27-30,40)	V _{OL}			0.45	V	VDD=4.5V IOL=17mA
				0.45		VDD=2.7V IOL=11mA
“H” output voltage (Pin number 5,7-9,11-14,19, 20,27-30,40)	V _{OH}	2.4			V	VDD=4.5V IOL=-26mA
		2.2				VDD=2.7V IOL=-5.2mA
“L” input voltage (Pin number 16(XT1_IN))	V _{IL3}	0		0.8	V	VDD=4.5V
		0		0.4		VDD=2.5V
“H” input voltage (Pin number 16(XT1_IN))	V _{IH3}	3.5		VDD+0.3	V	VDD=5.5V
		2.4		VDD+0.3		VDD=3.0V
“L” input voltage Schmitt (Pin number 4(nRESET))	V _{ILS}	-0.3		0.2VDD	V	
“H” input voltage Schmitt (Pin number 4(nRESET))	V _{IHS}	0.7VDD		VDD+0.3	V	
Vibration frequency	XIN		16.0		MHz	In USB mode Tolerance:±0.25%

5-3. Timing requirement

§ Power-on Reset

(VDD = 5.5, VSS = 0V, Ta = -40 to 105°C)

Item	Symbol	Limits			Unit	Description
		Minimum	Normal	Maximum		
Reset Voltage	VPOR	1.6	2	2.4	V	
VDD Start Voltage	VPOR			100	mV	
VDD Raising Rate	RRVDD	0.025			V/ms	
Minimum Time for VDD Stays at VPOR	tPOR	0.5			ms	

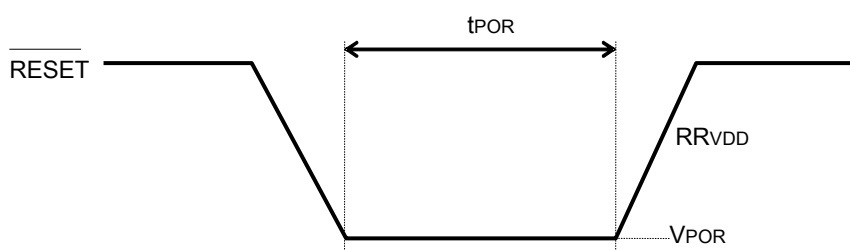

§ nRESET Reset

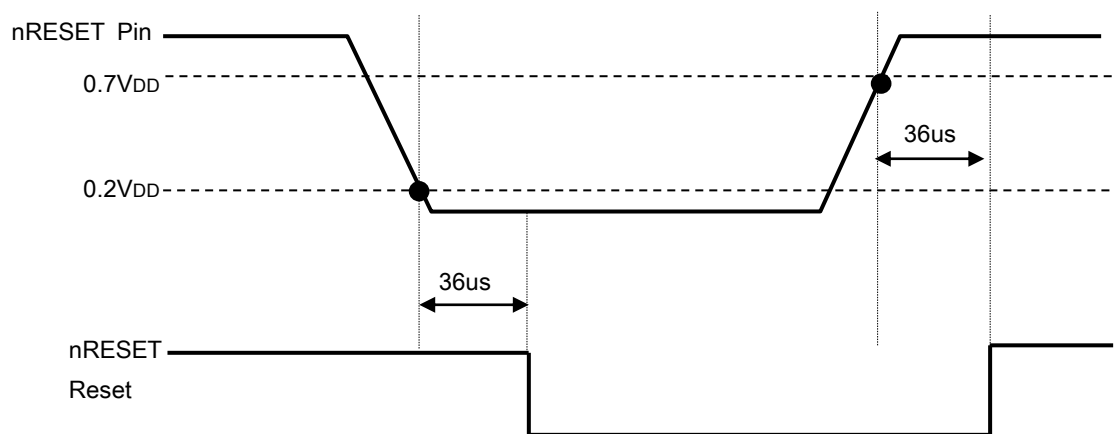

*Minimum pulse width 36us.

§ External clock timing

Item	Symbol	Limits			Unit	Description
		Minimum	TYP	Maximum		
Input cycle	t_c		62.5		ns	16MHz
Clock pulse width	t_{WH}, t_{WL}	10			ns	

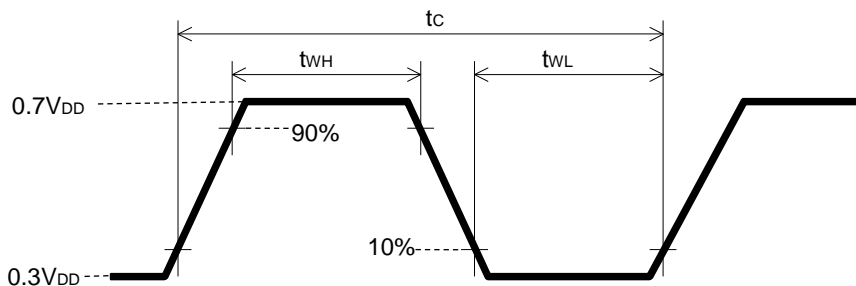

§ Clock input circuit

Using ceramic vibrator

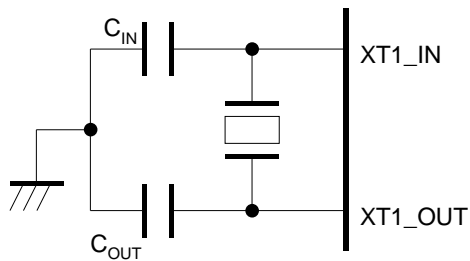

External clock input circuit

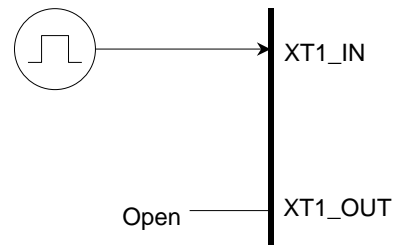

6. Packaging specification

6-1. Outline

With a basic packaging unit of 2,000pcs, TSC-50/IC is packaged for the number of 2,000 and its multiple using damp-proof aluminum bags (Basic packaging). If the delivery quantity is less than 2,000 or not multiple of 2000, or the product cannot be packaged with a unit of 2,000, then damp-proof aluminum laminate bags or no damp-proof packaging specification is applicable (Small group packaging).

If packaged with small group packaging, the products may be dampened. Before mounting, the product shall take the baking process as specified in [Baking] under the section "7. Storage specification".

6-2. Notes on storage/handling

- (1) Handle the packages with care and avoid throwing and dropping them. Or, a large impact may be imposed, causing packaging material's damage, broken package or bending lead.
- (2) Cardboard box may be deteriorated in its strength and deformed due to storage site's humidity, stacking condition and storage duration. It is desirable to keep the storage under normal temperature/humidity (5 to 30 °C, 40 to 60%RH). For warehousing, follow the FIFO principle.
- (3) After unpacking, be careful in handling the product to avoid electrostatic breakdown.

6-3. Basic packaging

§ Packaging type

Damp-proof packaging (Aluminum bag)

§ Packaging quantity specification

Quantity per tray	Number of trays	Quantity per packages
250	8 + 1(cover)	2,000

§ Packing sample

- ① Pile the trays up and bind them with a nylon tie.

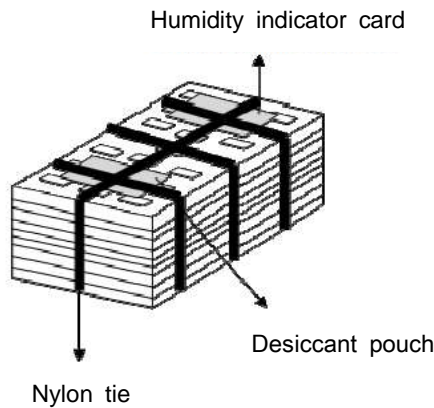

- ④ Put into inner box.

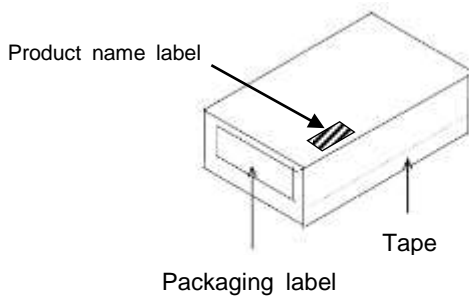

- ② Put the trays into an aluminum bag and pack with vacuum.

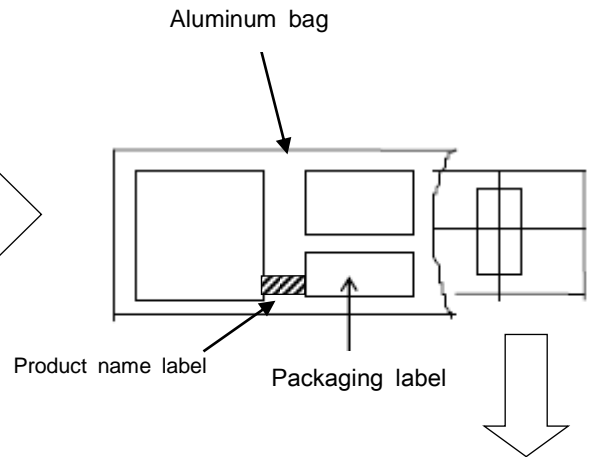

- ③ Cover the aluminum bag with EPE form sheet.

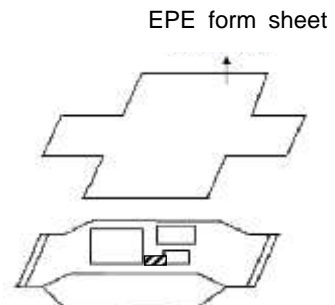

§ Diagram for packaging box sizes

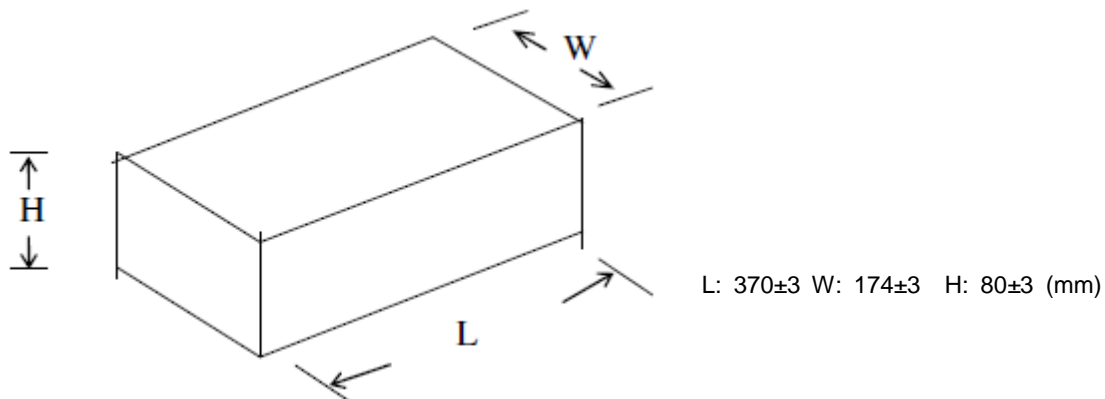

6-4. Small group packaging

§ Packaging type

General packaging (No damp-proof processing)

§ Packaging quantity specification

Quantity per tray	Number of trays	Quantity per packages
250	1 to 8 +1(cover)	1 - 1999

Packing sample

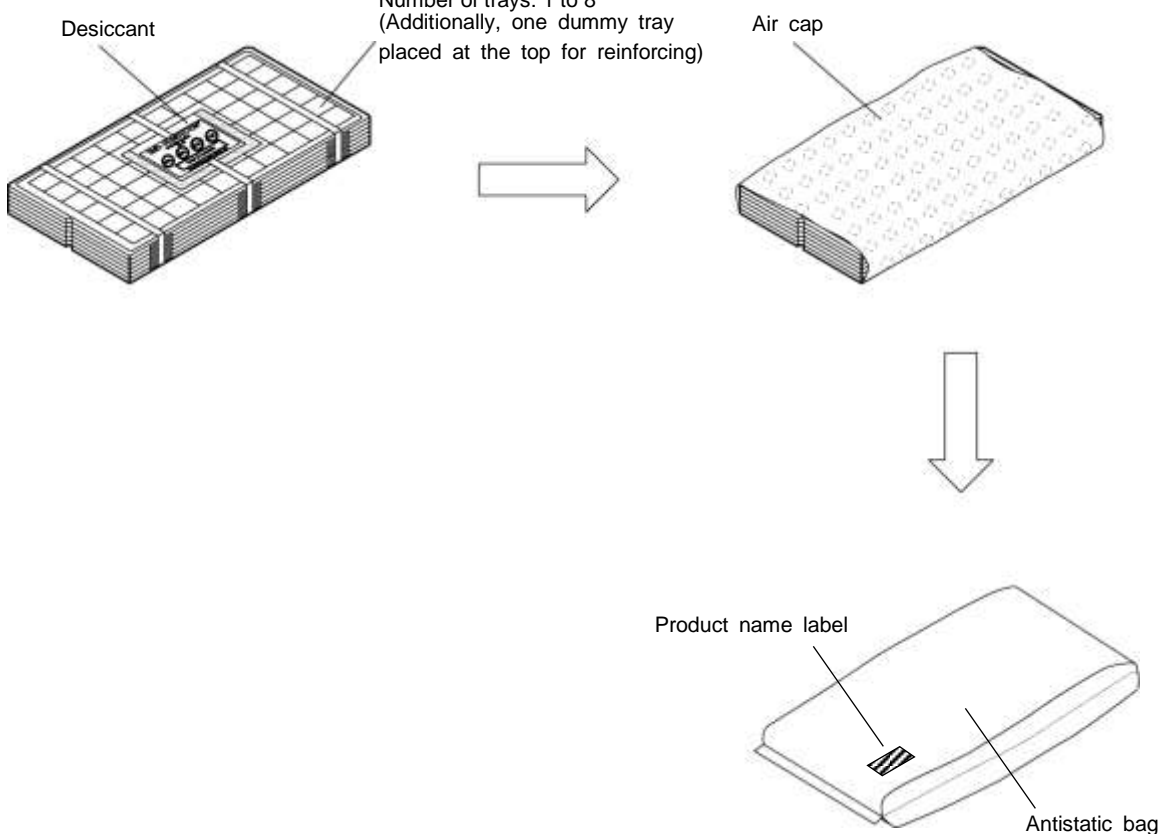

* No sizes specified for packaging box (Cardboard box) used for transportation.

* This is an example and may not be the same as supplies.

6-5. Tray specification

This tray is heat-proof type, allowing the heating with 125 °C for 24 hours. During heating/cooling process, however, bending may occur. In baking process, to minimize the bending, heat and cool the tray by placing it on a flat plate.

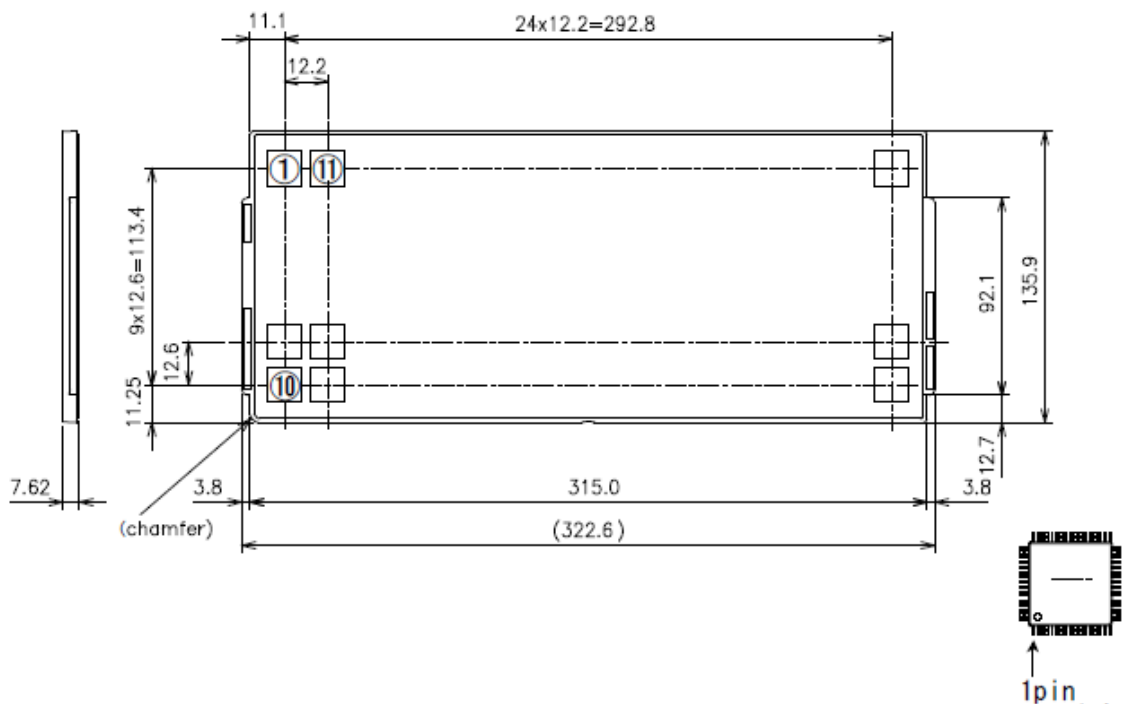

6-6. Product name label specification

- DMC P/N: Product number (TSC-50/IC)
- QTY: Quantity
- DAC: DMC Control Number



7. Storage specification

7-1. Storage conditions

For storing the product until its mounting, it is recommended that the following storage conditions are applied:

1. Before unpacking the damp-proof package (Aluminum bag)
 - Temperature and humidity: <math><40\text{ }^{\circ}\text{C}</math>, <math><90\%\text{RH}</math>
 - Duration: Within 12months

2. After unpacking the damp-proof package (Aluminum bag)

After the aluminum bag is opened, the products that will be subjected to reflow solder or other high temperature process must be

 - a. mounted within 168 hours of factory conditions<math><30\text{ }^{\circ}\text{C}</math> /60%RH, or
 - b. stored at <math><10\%\text{RH}</math>

7-2. Baking

The product requires bake, before mounting, if

1. Humidity indicator card is >10% when read at $23\pm 5^{\circ}\text{C}$
2. Neither a nor b in the item 2 in [7-1 Storage Conditions] section above is not satisfied.

You may place the tray used for damp-proof packaging directly into the thermostatic chamber since the tray is heat-proof type. When placing into the chamber or after removing from it, to avoid deformation, cool the tray by placing it on the flat plate such as surface table.

Baking method

Temperature: $125 \pm 5^{\circ}\text{C}$

Duration: 24 hours

8. Mounting specification

Temperature condition for mounting

If the product is to be mounted in high temperature such as reflow method, confirm the appropriate temperature in the temperature profile before mounting, because it depends on melting temperature of solder and paste materials.

Wave soldering method is not recommended.

1. Reflow method (Infrared reflow, air reflow)

Temperature: The following temperature profile is recommended.

Frequency: 3 times or less

Pb Free & Halogen Free IR-Profile

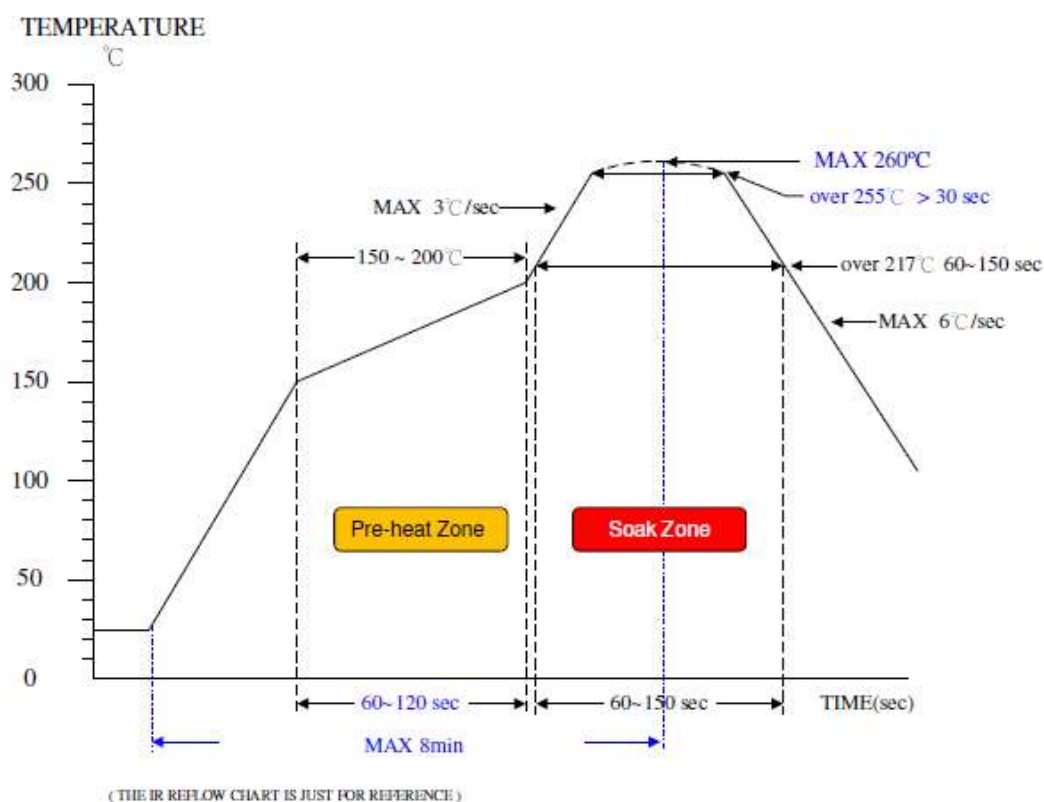

Figure 1: reflow temperature profile

2. Soldering iron (Manual soldering)

Soldering bit's temperature: 355±5 °C

Soldering time: 5 seconds or less/terminal

9. Terminal pin specification

Base material	:Cu alloy
Coat	:Tin (Sn)
Thickness of coat	:8 to 20um

10. Changes and improvements

10-1. Version history

§ TSC-50/IC

Ver 0.1 (December 1, 2015)

Draft release

Ver 0.2 (February 2, 2016)

Description mistakes in the circuit diagram were corrected (Rev0.1 → 0.2)

The corrected mistakes were as following.

- C4 : 2.2u→10pF
- C5 : 0.1u→10pF
- C12=C13=C14=C15 : 0.1uF → 1000p
- R9 was deleted from the diagrams for 4-wire Resistive Touch Screen

Ver1.0 (April 1, 2016)

First edition release

1-4. General specification Value of power consumption was added.

2. Pin layout and representation Marking specification was changed.

5-1. Absolute maximum rating Maximum Current into VDD and Maximum Current rating out of VSS were added

The new sections, [6. Packaging specification], [7. Storage specification], [8. Mounting specification,] and [9. Terminal pin specification] were added.

Circuit diagrams of 8-wire were added. (Rev.1)

Ver2.0 (December 20, 2016)

Descriptions about 8-wire are deleted.

1-4. General Specification: Power Consumption → Operating Current (description change), value changed

1-4. General Specification: Operation Frequency → [Internal CPU 72MHz] is added in [Notes]

3. Pin functions: Descriptions about serial connection are added in 24th and 35th pins.

5-2. Recommended Operational Condition: Description errors are corrected (no specification change)

5-3. Timing requirement: Descriptions about nRESET are added.

5-3. Timing requirement: External clock timing → TYP value is added.

8. Mounting Specification: Frequency is added.

Circuit Diagram: changes are as following (Rev.2)

24th (JP4) and 35th (JP5) pins are fixed to GND in serial mode.

Condenser is added between the reset terminal and GND.

Condenser capacitance connected to 18th and 36th pins is changed from 0.1uF to 1uF.

Condenser connected to D+/D- at USB connection is deleted.

Circuit diagrams for 8-wire are deleted.

11. Warranty

11-1. Warranty period

- § The warranty period is limited to 1 year from the date of shipping. The warranty for the initial deflection such as appearance deflection is limited to 1 month.
- § Any defected parts under proper use will be examined by the supplier and replaced by the new parts if the deflection is considered to be caused by the supplier.
- § The replacement is subject to be included in the next lot.

11-2. Warranty target

- § The warranty only covers the product itself and does not cover any damage to others caused by using this product. Onsite repair or replacement is not supported.
- § We will do our best for delivery problem and product defections, but the warranty for the production line is not covered.

11-3. Warranty exceptions

Following conditions are not covered with the warranty and subject to charge.

- § Any malfunctions and damages during transportation and transfer by the user.
- § Any malfunctions and damages caused by a natural disaster or a fire.
- § Any malfunctions and damages caused by static electricity
- § Any malfunctions and damages caused by the failure of the associated equipment.
- § If the product is remodeled, disassembled or repaired by the user.
- § If the product is glued onto the equipment and uninstalled.
- § Any malfunctions and damages caused by an improper usage and handling against the specifications and notes.

12. Notes on use

12-1. Overall handling

- § When using the product, do not place it close to, or make it contact with, the conductive materials such as metal.
- § Do not touch the metal part in the product directly with your hands. Or, it may be destructed by the static electricity. If you contact, or may contact, it directly with your hand, prepare in advance the measure against static electricity.
- § To store the product, use an appropriate packing box and keep the storage temperature range with no overload on it.
- § In using the product or storing it, avoid the following conditions:
 - Conditions where water is, or may be, attached to the product.
 - Conditions where condensation takes place, or may take place.
 - In the ambience of organic solvent or acidity or contact, or where the product contacts them.
- § Do not alter or disassemble the product.

12-2. Others

- § This specification may be changed for improvement without prior notices.
- § No liabilities are taken by us for any damage caused by use of this product.
- § This product intends to be used for the standard applications (e.g. office equipment and OA devices, industrial use, communication devices, household equipment). Avoid its use where failure or malfunction directly may affect the human body or special applications where extremely high reliability is required (e.g. airline and space industries, nuclear controls, medical use for life-sustaining).
- § Semi-conductor devices may fail in a certain possibility. Keep the safety design in your mind so that possible failure in this product shall not cause physical accidents such as injury and death, fire and other social damages.

TSC-50/IC Product Specification
Version 2.0: Issued at December 20, 2016
©2016 DMC Co., Ltd.

This document is allowed to redistribute but no alteration, part or all, is prohibited.

DMC Co., Ltd.

<http://www.dmccoltd.com/english/>
11F Takanawa Sengakuji Ekimae Bldg., 2-18-10 Takanawa, Minato-ku, Tokyo 108-0074, Japan
Phone: +81-3-6721-6731 (Japanese), 6736 (English) Fax: +81-3-6721-6732

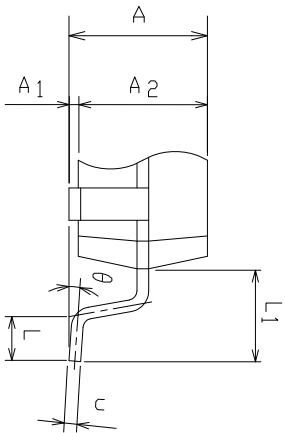
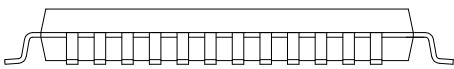
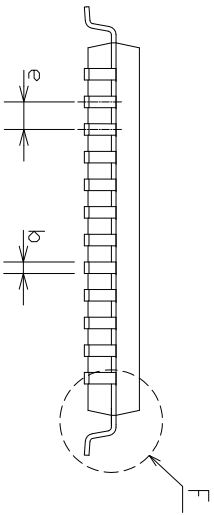
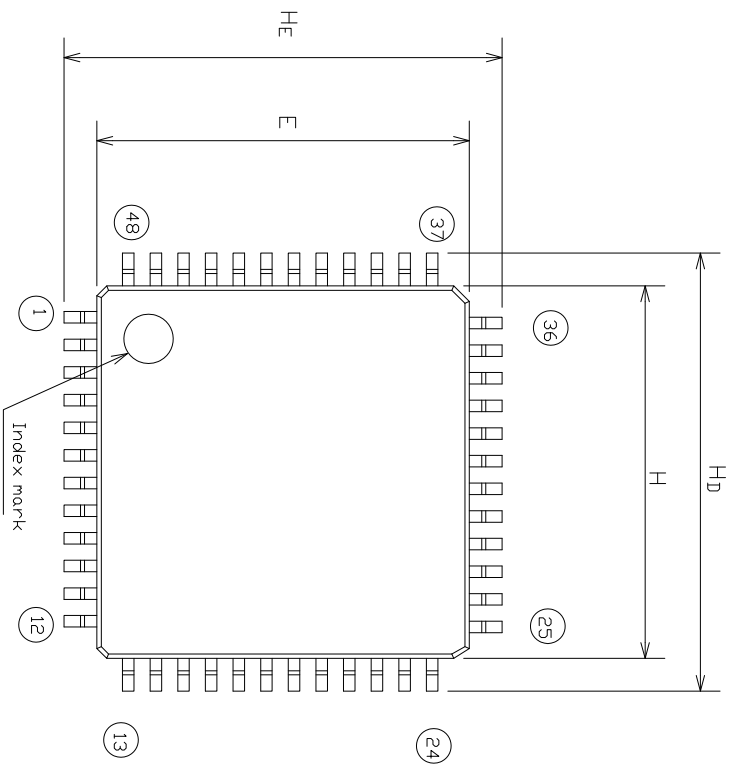

Detail F

Symbol	Dimension in Millimeters		
	Min	Nom	Max
A	-	-	-
A1	0.05	0.10	0.15
A2	1.35	1.40	1.45
b	0.15	0.20	0.25
c	0.10	0.15	0.20
D	6.90	7.00	7.10
E	6.90	7.00	7.10
e	0.35	0.50	0.65
Hd	8.90	9.00	9.10
HE	8.90	9.00	9.10
L	0.45	0.60	0.75
L1	-	1.00	-
Y	-	-	0.10
θ	0°	-	7°

©DMC Co., Ltd.

Date	March 30, 2016	P/N	TSC-50/IC
Name	Dimensional Drawing Rev.1.0		
DMC Co., Ltd.			

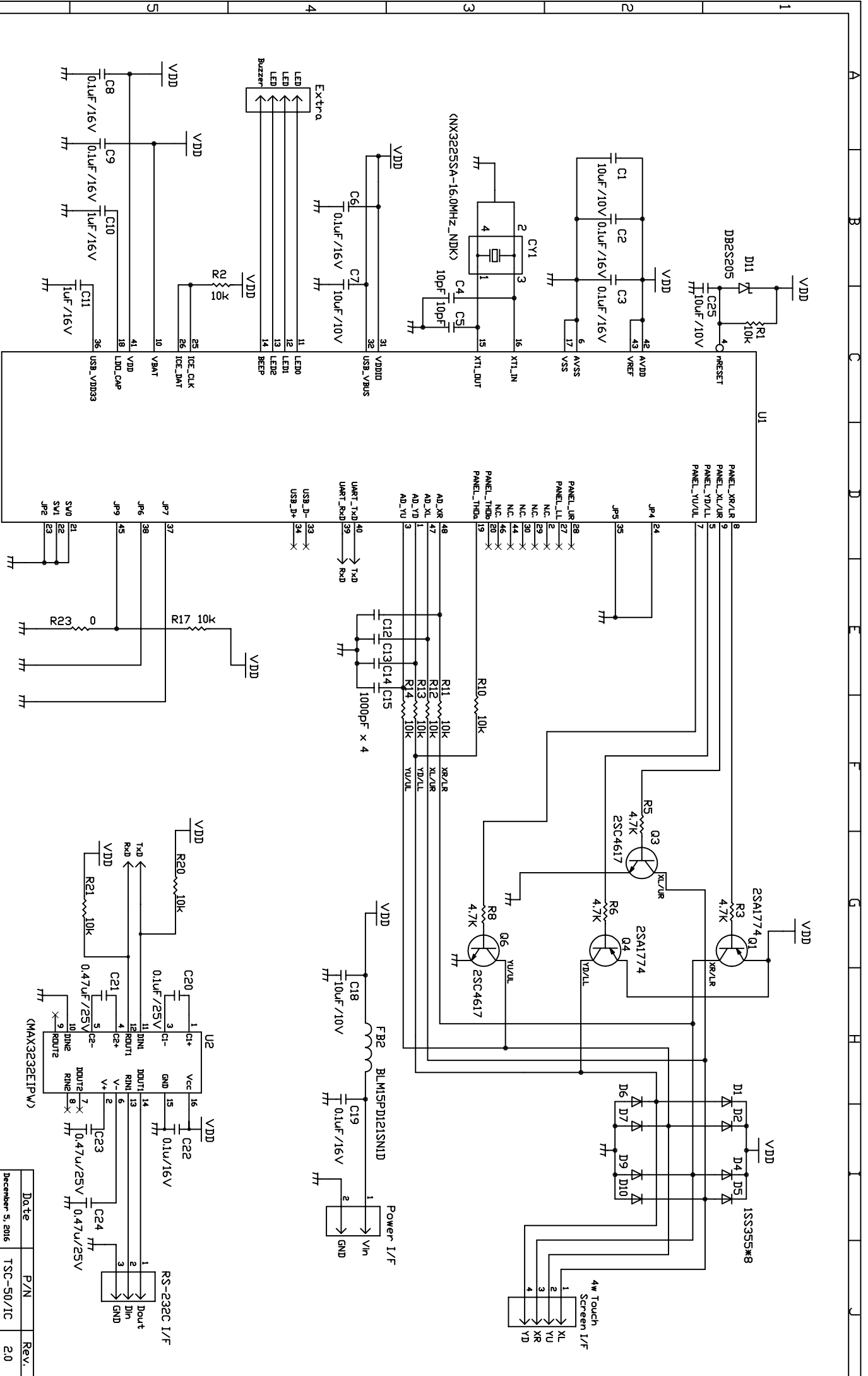

Enable EEPROM : Delete R17
 Disable EEPROM : Delete R23

TSC-50/1C

Date	P/N	Rev.
December 5, 2016	TSC-50/1C	2.0

4-Wire Resistive Touch Screen
 RS-232C I/F Circuit Diagram
 DMC Co., Ltd.

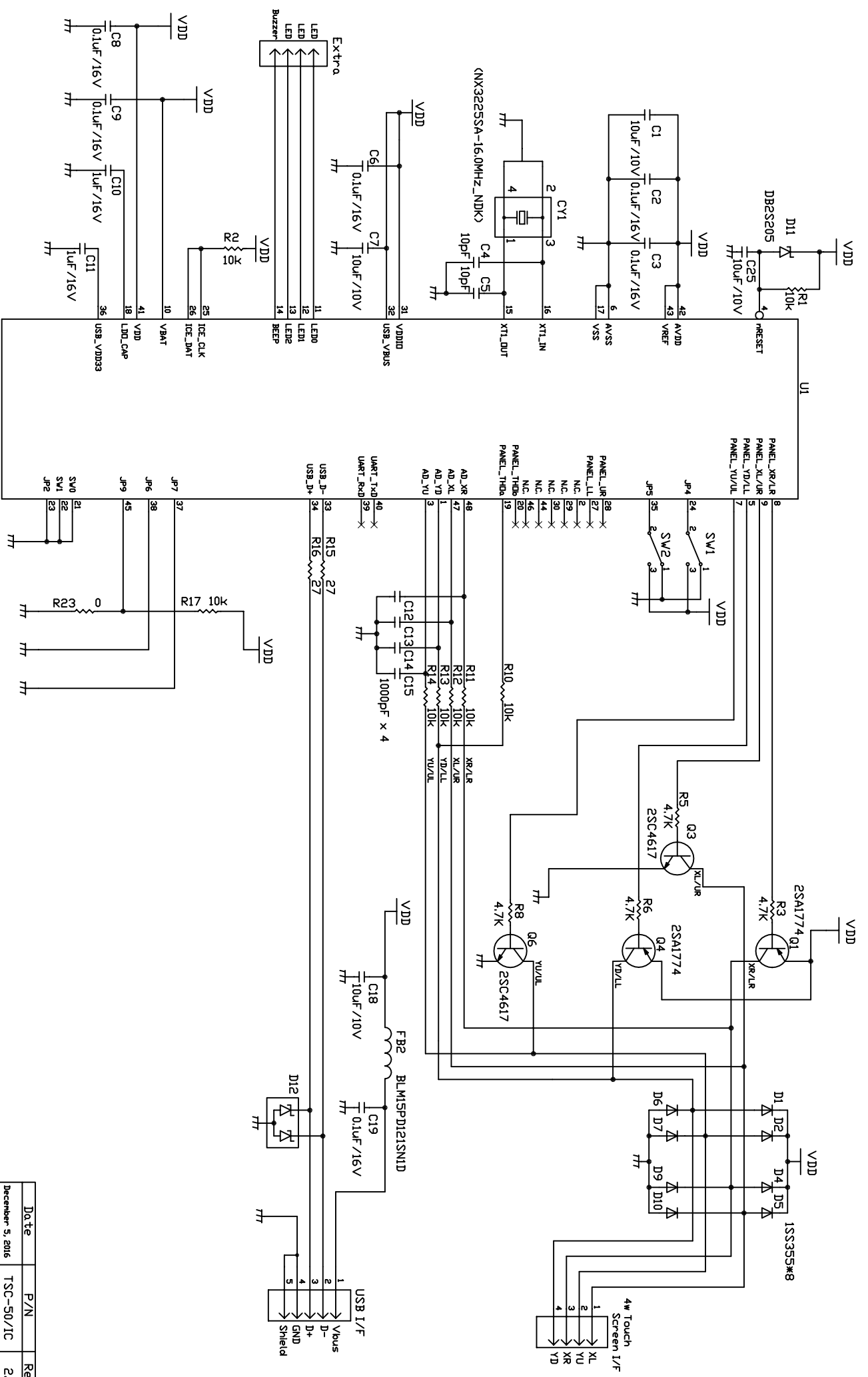

TSC-50/IC

Enable EEPROM : Delete R17
 Disable EEPROM : Delete R23

Date	P/N	Rev.
December 5, 2016	TSC-50/IC	2.0

4-Wire Resistive Touch Screen
 USB I/F Circuit Diagram

DMC Co., Ltd.

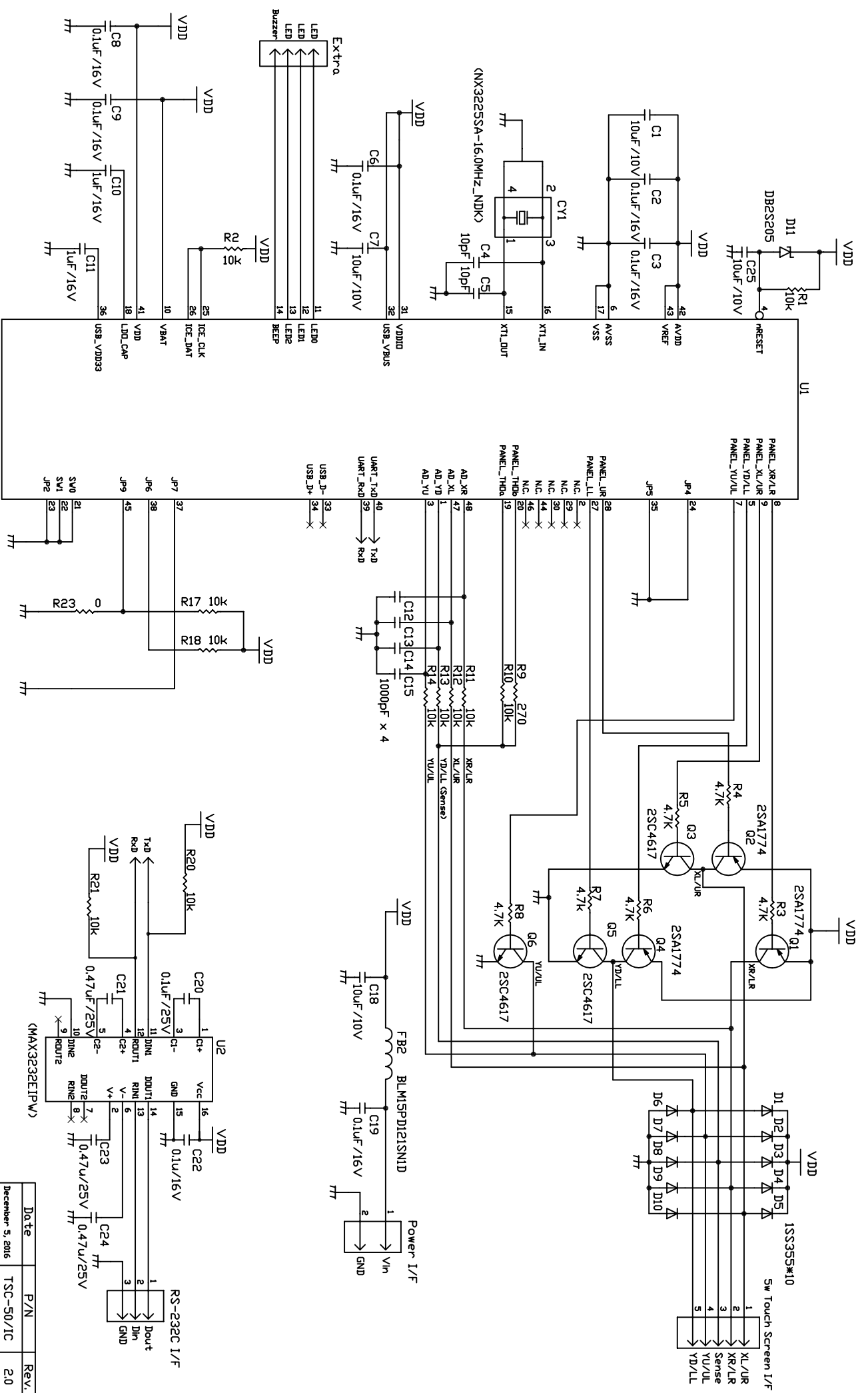

Enable EEPROM : Delete R17
 Disable EEPROM : Delete R23

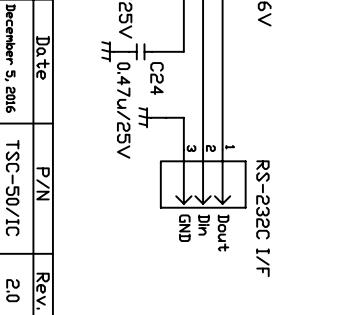

© DMC Co., Ltd.
 This document is to be used as a reference guide only.
 DMC assumes no liability for applications assistance or customer product design.
 DMC does not warrant or represent that any license is granted under patent or other rights.

Date	P/N	Rev.
December 5, 2016	TSC-50/1C	2.0

Name
 5-Wire Resistive Touch Screen
 RS-232C I/F Circuit Diagram
 DMC Co., Ltd.

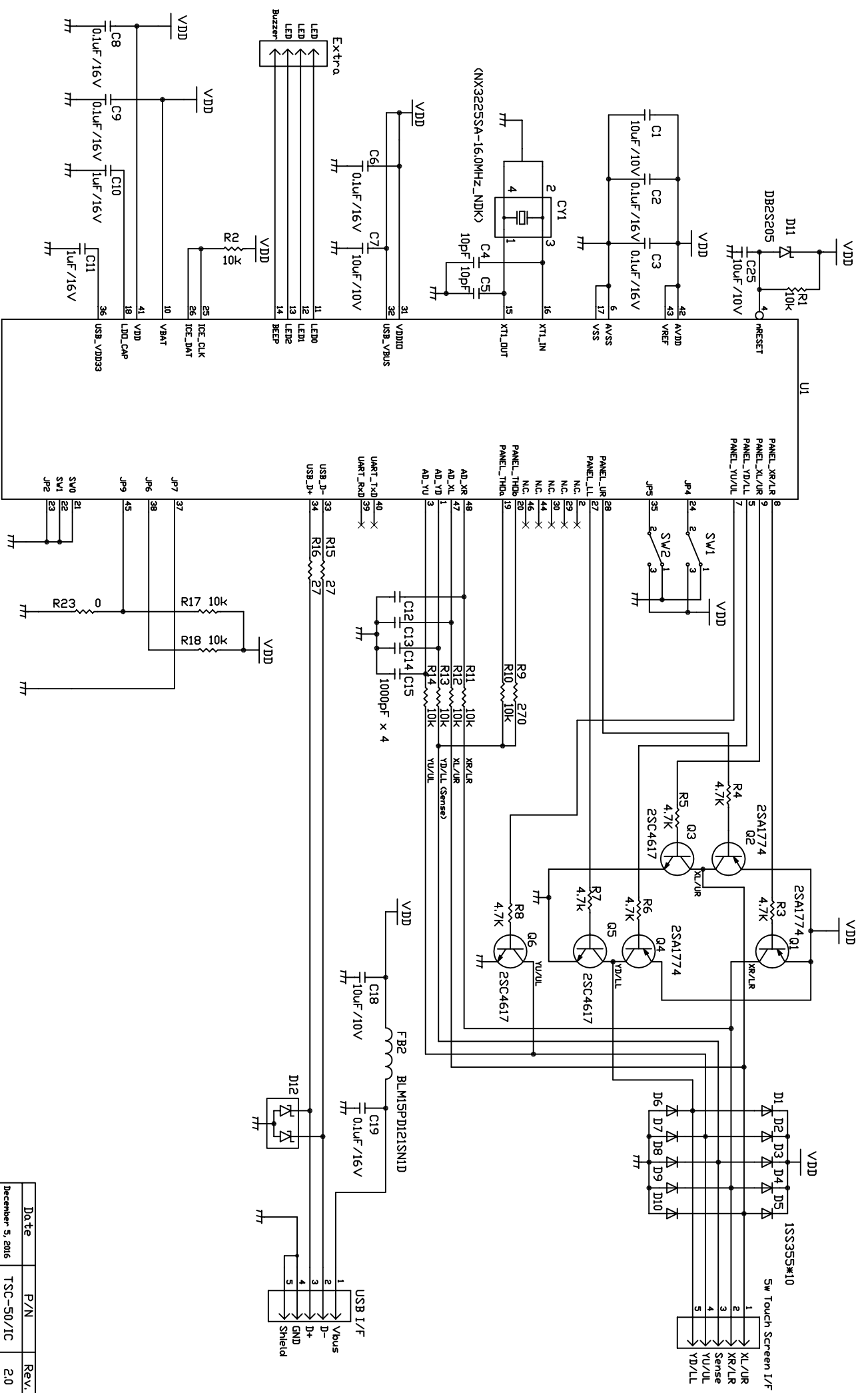

TSC-50/1C

Enable EEPROM : Delete R17
 Disable EEPROM : Delete R23

1 2 3 4 5 6

1 2 3 4 5 6

Date	P/N	Rev.
December 5, 2016	TSC-50/1C	2.0

5-Wire Resistive Touch Screen
 USB I/F Circuit Diagram

DMC Co., Ltd.

© DMC Co., Ltd.
 This document is to be used as a reference guide only.
 DMC assumes no liability for applications assistance or customer product design.
 DMC does not warrant or represent that any license is granted under patent or other rights.