

Data Sheet IVS-282

Version 1.2 - 05.03.2019

designed
and manufactured
in Germany

PRODUCT FAMILY

K-Band Transceiver

APPLICATIONS

- Traffic Monitoring
- Industrial Applications

- Movement
- Velocity
- Direction
- Presence
- Distance
- Angle

FEATURES:

- » Radar-based distance, speed & motion sensor
- » Advanced MMIC Technology
- » Integrated Low Noise Amplifier
- » Extended temperature range from -40°C up to +85°C
- » Shutdown feature for low power operation
- » Integrated Prescaler

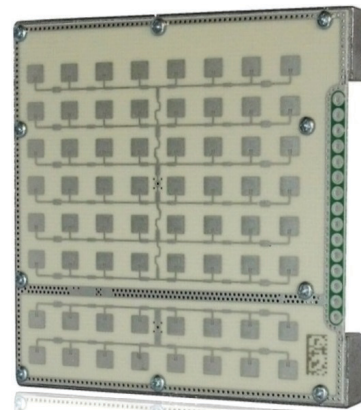

DESCRIPTION

High sensitivity K-Band FMCW Radar with I Q - outputs.

The shutdown option can be used for intermittent operation in battery powered applications.

ETSI / FCC

The IVS-282 module is compliant to ETSI 300 440 and FCC 15.245.

ADDITIONAL INFORMATION

InnoSenT Standard Product. Changes will not be notified as long as there is no influence on form, fit and within this data sheet specified function of the product.

CERTIFICATES

InnoSenT GmbH has established and applies a quality system for development, production and sales of radar sensors for industrial and automotive sensors.



RoHS-INFO

This product is compliant to the restriction of hazardous substances (RoHS - European Union directive 2011/65/EU).

CONFIDENTIAL AND PROPRIETARY

The information contained in this document shall remain the sole and exclusive property of InnoSenT GmbH and shall not be disclosed by the recipient to third parties without prior consent of InnoSenT in writing.

APPLICATION INFORMATION

The frequency can be monitored @ Pin 'DIV_OUT'

ELECTRICAL CHARACTERISTICS

PARAMETER	CONDITIONS	SYMBOL	MIN	TYP	MAX	UNITS
Radar						
transmit frequency		f	24.000		24.250	GHz
output power (EIRP)		P _{out}			20	dBm
varactor tuning voltage		V _{tune}	0.7		2.5	V
tuning slope				720	2000	MHz/V
IF output DC-Offset		U _{DC-offset}	1.4	1.8	2.2	V
IF-Bandwidth (-3dB)		B	0		1M	Hz
signal level	(RCS = 10m ² @ 50m)	IF _{ID}		300		μVrms
noise level	100Hz...1kHz	N _{1/2}		15		μVrms
quadrat. phase imbalance		ε _p	-25		25	°
overall gain	conversion gain + antenna gain	G _{OA}		54		dB
divider ratio depending on PIN_7	high (2.7V - 3.3V)			8192		
divider ratio depending on PIN_7	low (0 - 0.6V)			16		
divider output voltage	term with 50Ω			120		mV
Power supply						
supply voltage	transceiver	V _{CC}	3.2	3.3	3.4	V
supply current	transceiver	I _{CC}		73	86	mA
Environment						
operating temperature		T _{OP}	-40		+85	°C
storage temperature		T _{STG}	-40		+85	°C
Mechanical Outlines						
outline dimensions	compare to schematic on page 4	height length width		10.2 70 65.8		mm
varactor tuning impedance				tbd		Ω
modulation input					tbd	kHz

CONFIDENTIAL AND PROPRIETARY

The information contained in this document shall remain the sole and exclusive property of InnoSenT GmbH and shall not be disclosed by the recipient to third parties without prior consent of InnoSenT in writing.

SIMULATED ANTENNA PATTERN

Antenna Orientation:

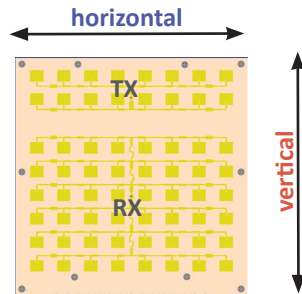

System Pattern (without radome)

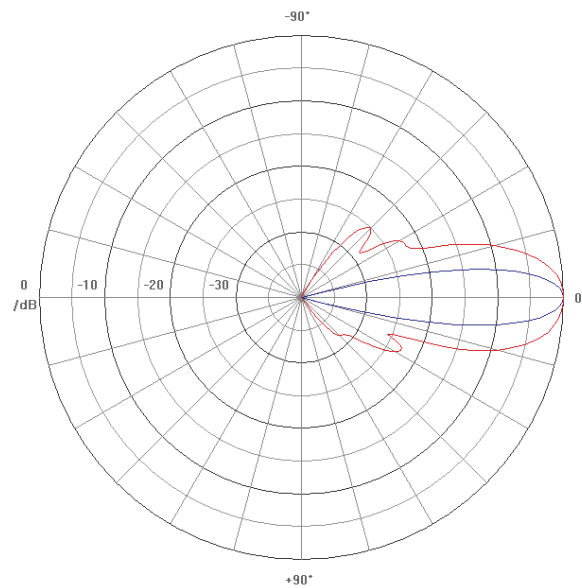
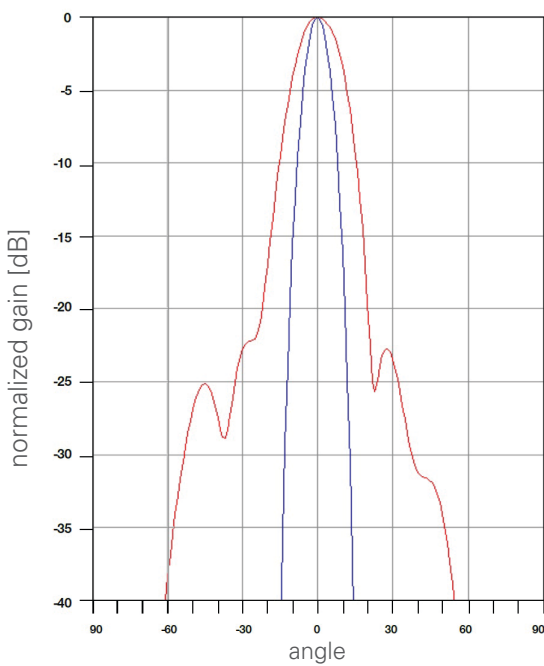

PARAMETER	CONDITIONS	SYMBOL	MIN	TYP	MAX	UNITS
System beam width @ -3dB		horizontal		9		°
		vertical		18		°

CONFIDENTIAL AND PROPRIETARY

The information contained in this document shall remain the sole and exclusive property of InnoSenT GmbH and shall not be disclosed by the recipient to third parties without prior consent of InnoSenT in writing.

INTERFACE

The sensor provides a 2.54mm hole grid

PIN #	DESCRIPTION	IN / OUT	COMMENT
1	GND	input	analog ground
2	d.n.c.		don't connect, leave open
3	V_tune	input	frequency tuning
4	n.c.	n.c.	not connected
5	enable	input	active low, enables internal power supply
6	V _{CC}	input	supply voltage 3.3V
7	VCCP	input	controls the divider ratio (for details see page 2)
8	V _{CC divider}	input	supply voltage divider +3.3V
9	TX_ON	input	active high, enables transmit power
10	GND	input	analog ground
11	Q	output	Analog Output Quad Phase
12	I	output	Analog Output In Phase
13	GND	input	analog ground
14	DIV_OUT	output	divider signal depending on PIN_7 (for more details see page 2)
15	GND	input	analog ground

MECHANICAL OUTLINES

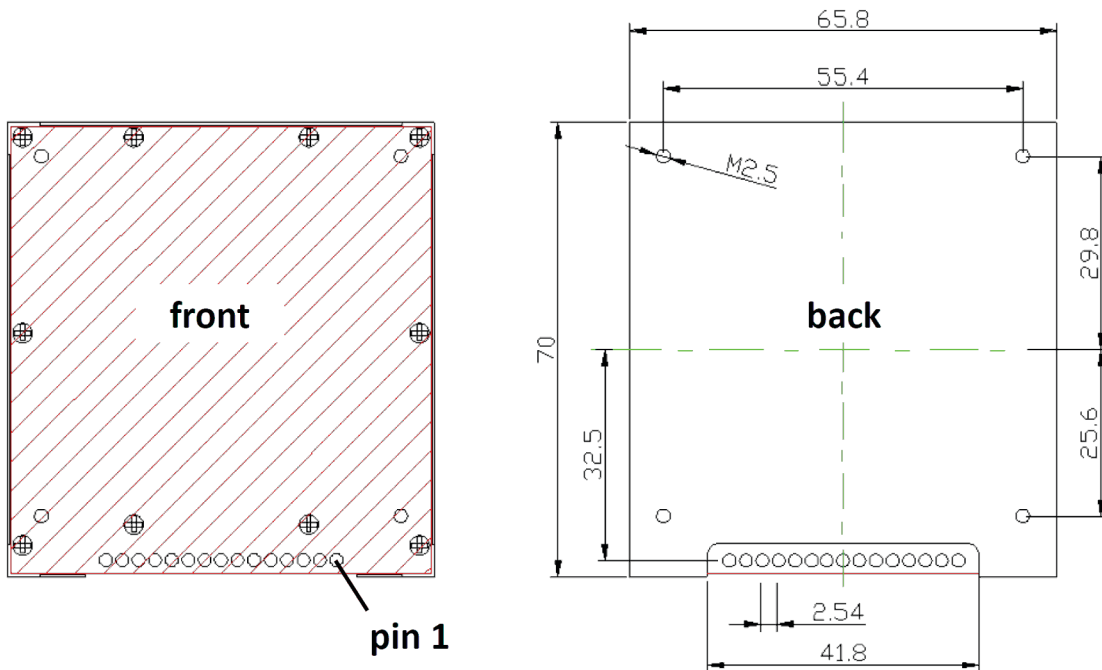

CONFIDENTIAL AND PROPRIETARY

The information contained in this document shall remain the sole and exclusive property of InnoSenT GmbH and shall not be disclosed by the recipient to third parties without prior consent of InnoSenT in writing.

APPROVAL

This Data Sheet contains the technical specifications of the described product. All previous versions of this Data Sheet are no longer valid.

The sensor uses Hydrocarbon based material which may change its dielectric properties when used in an oxidative environment. This may vary based on temperature. Therefore InnoSenT recommends evaluating this influence within the specific environment.

VERSION	DATE	COMMENT
1.0	11.07.2016	initial release
1.1	22.05.2017	small changes in interface
1.2	05.03.2019	small changes in interface

InnoSenT GmbH

Am Rödertor 30
97499 Donnersdorf
GERMANY

Tel.: +49 (0) 9528 - 9518 - 0
E-Mail: info@innosent.de
URL: www.innosent.de