

THIS DOCUMENT IS THE PROPERTY OF KEYSTONE ELECTRONICS CORP. AND SHALL NOT BE REPRODUCED, DISTRIBUTED OR USED AS A BASIS FOR MANUFACTURE WITHOUT PRIOR WRITTEN PERMISSION FROM KEYSTONE ELECTRONICS CORP.

ACTUAL SIZE

PANEL CUT

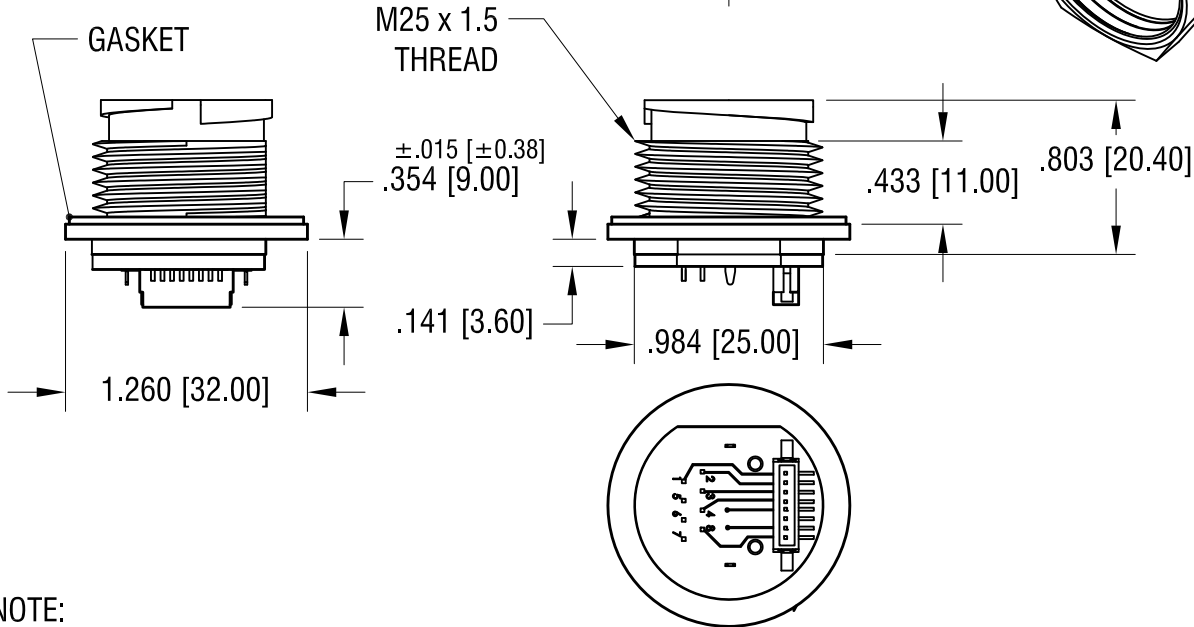
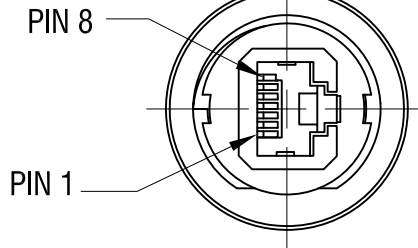
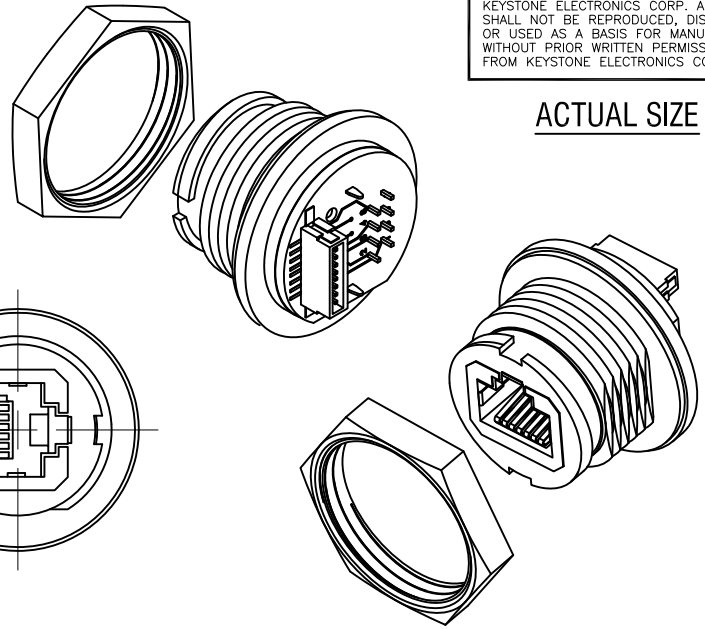
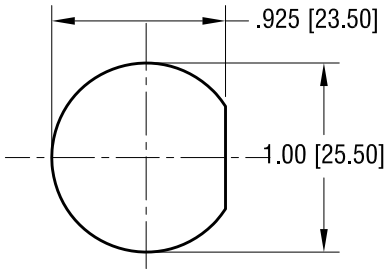

NOTE:

1. HOUSING: MAT'L- HIGH. TEMP.. THERMOPLASTIC
UL 94V-0
2. CONTACT: MAT'L- PHOSPHOR BRONZE
FINISH ON SOLDER AREA: TIN PLATE, OVER NICKEL
FINISH ON CONTACT AREA: GOLD PLATE, OVER NICKEL
3. GASKET: MAT'L- SILICON (RED COLOR)
4. JAM NUT M25 x 1.5 , 1.114 [28.30] HEX.
MAT'L- HIGH. TEMP. THERMOPLASTIC, UL 94V-0
SUPPLIED UNASSEMBLED

KEYSTONE ELECTRONICS CORP.			
www.keyelco.com • NEW HYDE PARK, NY 11040 • Tel (516) 328-7500			
PART NAME			
OFF BOARD WATERPROOF KEYSTONE JACK			
MATERIAL			
AS NOTED			
FINISH		DRN BY	DATE
AS NOTED		NT	12.21.18
		APP'D	SCALE
		RH	1X
TOLERANCES	INCH	[MM]	CODE
DECIMAL	± .005	[± 0.13]	C
ANGULAR	± 1°		
UNLESS OTHERWISE SPECIFIED			
DWG NO.		986	

DATE	DESCRIPTION	REV.