

YM = date code

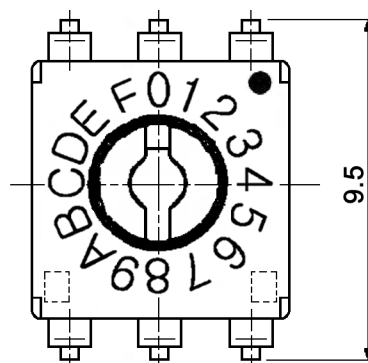
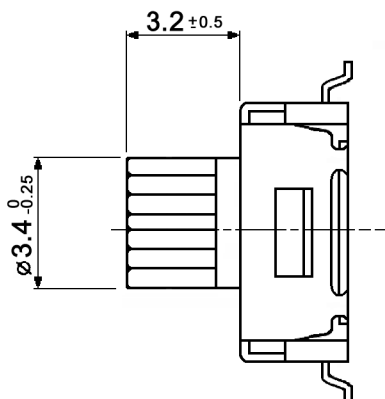

Y Manufacturing year

8	2008
9	2009
0	2010
1	2011
2	2012

M Manufacturing month

1	January
...	...
9	September
0	October
N	November
D	December

SURFACE MOUNT PAD LAYOUT

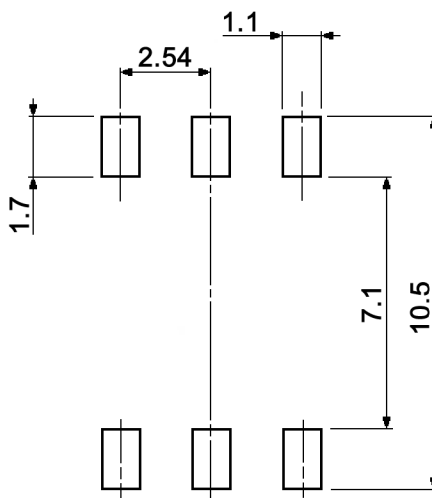

Compliance: RohS II (2011/65/EU)

Tolerances: ±0.5mm			Date	Name
			10/96	ey
Sealing	01/17	dr		
Contact system	02/15	dr		
Revised	03/13	dr		
Ordering code	08/12	dr		
Date code	03/10	dr		
Dimensions	09/08	dr		
Modifications	Date	Name		

SMR 13 000 / SMR 14 000

knitter-switch

20 26 06

Page

1/3

**Specifications:**

**Contact rating:** max.: non-switching: 100mA, 50V DC  
switching: 100mA, 5V DC  
min.: 1µA, 20mV AC or DC

**Contact resistance:** 200mOhm max. at 1.5mA; 0.2mV AC (1kHz)

**Insulation resistance:** 1 000MOhm min. at 100V DC

**Dielectric strength:** 250V AC for 1 minute

**Operating temperature:** -25°C to +75°C

**Storage temperature:** -40°C to +85°C

**Mechanical life:** 20 000 cycles min.

**Operating force:** 24.5mN.m max.

**Contact system:** self-cleaning sliding contacts

**Sealing:** by O-ring, washable by aqueous detergents and isopropyl alcohol

**Material:** Terminal: phosphor bronze, gold over nickel plated  
Base: liquid crystal polymer, black  
Frame: stainless steel  
Rotor: polyamide resin  
Fixed contact: phosphor bronze, gold over nickel plated  
Movable contact: beryllium copper, gold over nickel plated

**Soldering conditions:**

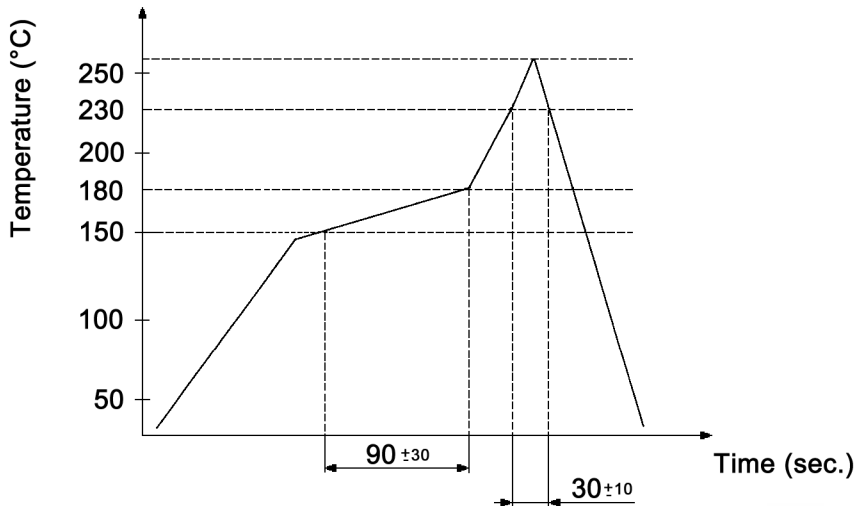

reflow soldering: 230°C, 30sec.; peak temperature: 260°C, 10sec. max.

**Packaging:**

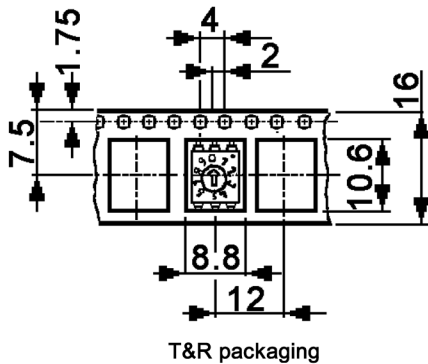

**Compliance: RohS II (2011/65/EU)**

Tolerances: ±0.5mm	Date	Name	<b>SMR 13 000 / SMR 14 000</b>
	10/96	ey	
			<b>knitter-switch</b>
			<b>20 26 06</b>
			Page
			2/3
Modifications	Date	Name	

**BCD**

		Real coded				
		C	1	2	4	8
10 Positions	0	●				
	1	●	●			
	2	●		●		
	3	●	●			
	4	●			●	
	5	●	●			●
	6	●		●	●	
	7	●	●	●	●	
	8	●				●
	9	●	●			●

**Hexadecimal**

		Real coded				
		C	1	2	4	8
16 Positions	0	●				
	1	●	●			
	2	●		●		
	3	●	●			
	4	●			●	
	5	●	●			●
	6	●		●	●	
	7	●	●	●	●	
	8	●				●
	9	●	●			●
	A	●		●		●
	B	●	●	●		●
	C	●			●	●
	D	●		●	●	
	E	●		●	●	●
	F	●	●	●	●	●

**BCD inverse**

		Complement coded				
		C	1	2	4	8
10 Positions	0	●	●	●	●	●
	1	●		●	●	●
	2	●	●		●	●
	3	●			●	●
	4	●	●	●		●
	5	●		●		●
	6	●	●			●
	7	●				●
	8	●	●	●	●	
	9	●		●	●	

**Hexadecimal inverse**

		Complement coded				
		C	1	2	4	8
16 Positions	0	●	●	●	●	●
	1	●		●	●	●
	2	●	●		●	●
	3	●			●	●
	4	●	●	●		●
	5	●		●		●
	6	●	●			●
	7	●				●
	8	●	●	●	●	
	9	●		●	●	
	A	●	●		●	
	B	●		●		
	C	●	●	●		
	D	●		●		
	E	●	●			
	F	●				

Ordering code	Actuation	Code	Packing
SMR 13010	screw driver	10 pos. real, ivory	65 pcs/tube
SMR 13010 T	screw driver	10 pos. real, ivory	1000 pcs/reel
SMR 14010	shaft	10 pos. real, ivory	65 pcs/tube
SMR 14010 T	shaft	10 pos. real, ivory	500 pcs/reel
SMR 13016	screw driver	16 pos. real, ivory	65 pcs/tube
SMR 13016 T	screw driver	16 pos. real, ivory	1000 pcs/reel
SMR 14016	shaft	16 pos. real, ivory	65 pcs/tube
SMR 14016 T	shaft	16 pos. real, ivory	500 pcs/reel
SMR 13110	screw driver	10 pos. inverse, red	65 pcs/tube
SMR 13110 T	screw driver	10 pos. inverse, red	1000 pcs/reel
SMR 14110	shaft	10 pos. inverse, red	65 pcs/tube
SMR 14110 T	shaft	10 pos. inverse, red	500 pcs/reel
SMR 13116	screw driver	16 pos. inverse, red	65 pcs/tube
SMR 13116 T	screw driver	16 pos. inverse, red	1000 pcs/reel
SMR 14116	shaft	16 pos. inverse, red	65 pcs/tube
SMR 14116 T	shaft	16 pos. inverse, red	500 pcs/reel

Compliance: RohS II (2011/65/EU)

Tolerances: ±0.5mm	Date	Name	<b>SMR 13 000 / SMR 14 000</b>
	10/96	ey	
	<b>knitter-switch</b>		<b>20 26 06</b>
			Page
			3/3
Modifications	Date	Name	