

Low Skew, Low Additive Jitter, 10 output LVPECL/LVDS/HCSL Fanout Buffer with one LVCMOS output

Features

- 3 to 1 input Multiplexer: Two inputs accept any differential (LVPECL, HCSL, LVDS, SSTL, CML, LVCMOS) or a single ended signal and the third input accepts a crystal or a single ended signal
- Ten differential LVPECL/LVDS/HCSL outputs
- One LVCMOS output
- Ultra-low additive jitter: 24fs (integration band: 12kHz to 20MHz at 625MHz clock frequency)
- Supports clock frequencies from 0 to 1.6GHz
- Supports 2.5V or 3.3V power supplies on LVPECL, LVDS or HCSL outputs
- Supports 1.5V, 1.8V, 2.5V or 3.3V on LVCMOS outputs
- Embedded Low Drop Out (LDO) Voltage regulator provides superior Power Supply Noise Rejection
- Maximum output to output skew of 40ps
- Device controlled via control pins

Ordering Information

| | | |
|------------------------|------------|---------------|
| ZL40231LDG1 | 48 Pin QFN | Trays |
| ZL40231LDF1 | 48 pin QFN | Tape and Reel |
| Package size: 7 x 7 mm | | |
| -40°C to +85°C | | |

Applications

- General purpose clock distribution
- Low jitter clock trees
- Logic translation
- Clock and data signal restoration
- Wired communications: OTN, SONET/SDH, GE, 10 GE, FC and 10G FC
- PCI Express generation 1/2/3/4 clock distribution
- Wireless communications
- High performance microprocessor clock distribution
- Test Equipment

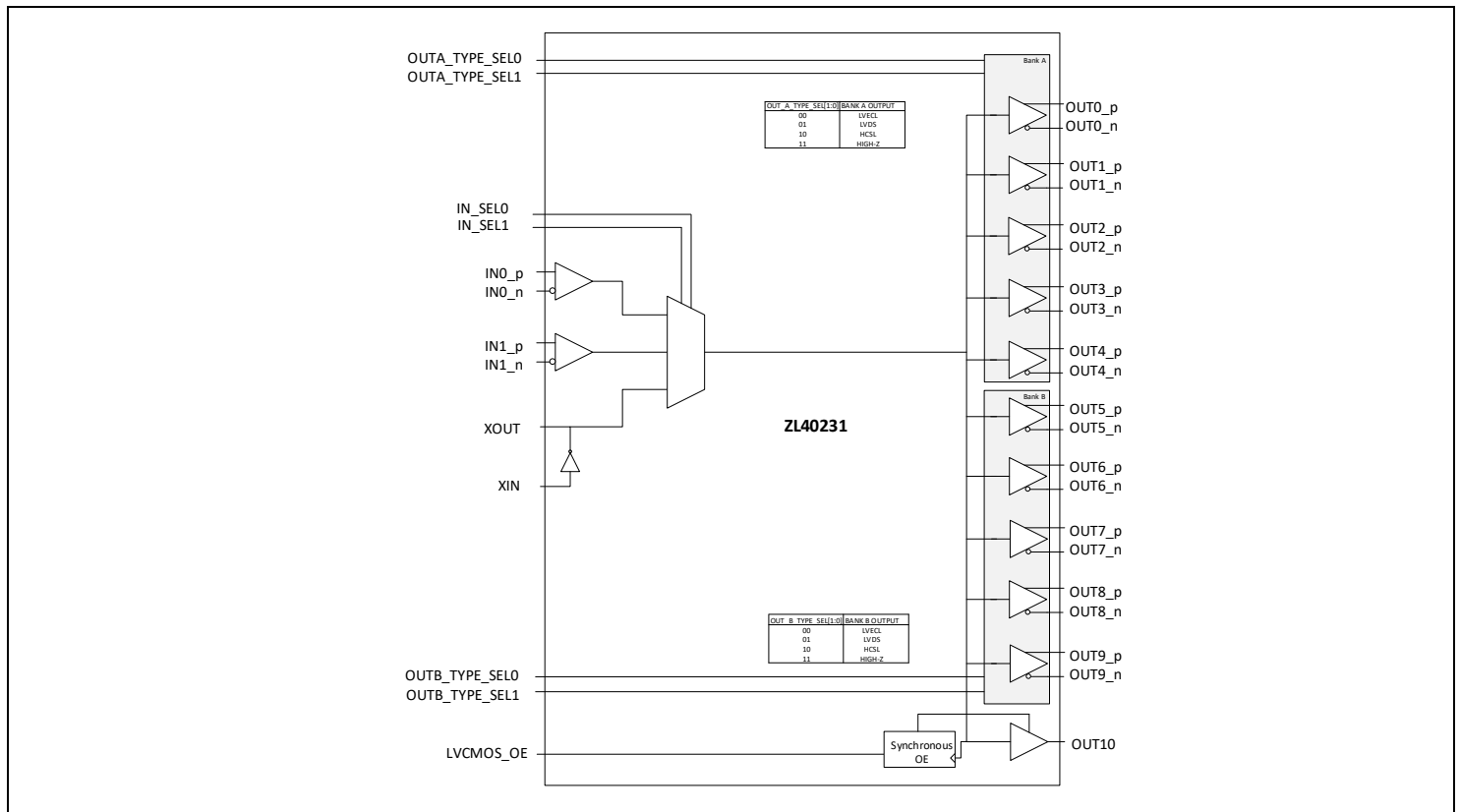

Figure 1. Functional Block Diagram

Table of Contents

| | |
|--|----|
| Features..... | 1 |
| Applications..... | 1 |
| Table of Contents | 2 |
| Pin Diagram | 5 |
| Pin Descriptions..... | 6 |
| Functional Description | 9 |
| Clock Inputs | 9 |
| Clock Outputs | 12 |
| Crystal Oscillator Input..... | 13 |
| Termination of unused inputs and outputs | 13 |
| Power Consumption | 13 |
| Power Supply Filtering..... | 14 |
| Power Supplies and Power-up Sequence | 14 |
| Host Interface | 15 |
| Typical device performance..... | 16 |
| AC and DC Electrical Characteristics | 20 |
| Absolute Maximum Ratings..... | 20 |
| Recommended Operating Conditions | 20 |
| Change History | 34 |
| Package Outline | 35 |

List of Figures

| | | |
|------------|---|----|
| Figure 1. | Functional Block Diagram..... | 1 |
| Figure 2. | Pin Diagram | 5 |
| Figure 3. | Input driven by a single ended output | 9 |
| Figure 4. | Input driven by DC coupled LVPECL output..... | 9 |
| Figure 5. | Input driven by DC coupled LVPECL output (alternative termination)..... | 10 |
| Figure 6. | Input driven by AC coupled LVPECL output..... | 10 |
| Figure 7. | Input driven by HCSL output | 10 |
| Figure 8. | Input driven by LVDS output | 11 |
| Figure 9. | Input driven by AC coupled LVDS | 11 |
| Figure 10. | Input driven by an SSTL output | 11 |
| Figure 11. | Termination for LVCMOS output | 12 |
| Figure 12. | Driving a load via transformer..... | 12 |
| Figure 13. | Crystal Oscillator Circuit..... | 13 |
| Figure 14. | Power Supply Filtering | 14 |
| Figure 15. | 156.25MHz LVPECL..... | 16 |
| Figure 16. | 1.5GHz LVPECL..... | 16 |
| Figure 17. | 156.25MHz LVDS | 16 |
| Figure 18. | 1.5GHz LVDS | 16 |
| Figure 19. | 100MHz HCSL..... | 16 |
| Figure 20. | 250MHz HCSL..... | 16 |
| Figure 21. | I/O delay vs temperature..... | 17 |
| Figure 22. | PSNR vs noise frequency..... | 17 |
| Figure 23. | 100MHz LVPECL Phase Noise..... | 17 |
| Figure 24. | 100MHz LVDS Phase Noise | 17 |
| Figure 25. | 25MHz LVDS Phase Noise in Xtal mode | 17 |
| Figure 26. | 100MHz HCSL Phase Noise | 17 |
| Figure 27. | 156.25MHz LVPECL Phase Noise..... | 18 |
| Figure 28. | 625MHz LVPECL Phase Noise..... | 18 |
| Figure 29. | 156.25MHz LVDS Phase Noise | 18 |
| Figure 30. | 625MHz LVDS Phase Noise | 18 |
| Figure 31. | Output RMS jitter (12kHz to 20MHz) vs input clock slew-rate | 19 |
| Figure 32. | Output clock noise floor vs input clock slew-rate | 19 |
| Figure 33. | Output RMS jitter (12kHz to 20MHz) vs input clock slew-rate | 19 |
| Figure 34. | Output clock noise floor vs input clock slew-rate | 19 |
| Figure 35. | Output RMS jitter (12kHz to 20MHz) vs input clock slew-rate | 19 |
| Figure 36. | Output clock noise floor vs input clock slew-rate | 19 |
| Figure 37. | Differential Input Voltage Levels | 21 |
| Figure 38. | Differential Output Voltage Levels | 25 |

List of Tables

| | |
|---|----|
| Table 1 Pin Descriptions | 6 |
| Table 2 Input clock selection | 15 |
| Table 3 Output Type Selection..... | 15 |
| Table 4 Absolute Maximum Ratings*..... | 20 |
| Table 5 Recommended Operating Conditions*..... | 20 |
| Table 6 Current consumption | 20 |
| Table 7 Input Characteristics*..... | 21 |
| Table 8 Crystal Oscillator Characteristics*..... | 22 |
| Table 9 Power Supply Rejection Ratio for $VDD = VDDO = 3.3V^*$ | 22 |
| Table 10 Power Supply Rejection Ratio for $VDD = VDDO = 2.5V^*$ | 23 |
| Table 11 LVCMOS Output Characteristics for $VDDO = 3.3V^*$ | 23 |
| Table 12 LVCMOS Output Characteristics for $VDDO = 2.5V^*$ | 24 |
| Table 13 LVPECL Output Characteristics for $VDDO = 3.3V^*$ | 25 |
| Table 14 LVPECL Output Characteristics for $VDDO = 2.5V^*$ | 26 |
| Table 15 LVDS Outputs for $VDDO = 3.3V^*$ | 27 |
| Table 16 LVDS Outputs for $VDDO = 2.5V^*$ | 28 |
| Table 17 HCSL Outputs for $VDDO = 3.3V^*$ | 29 |
| Table 18 HCSL Outputs for $VDDO = 2.5V^*$ | 30 |
| Table 19 LVCMOS Output Phase Noise with 25 MHz XTAL*..... | 31 |
| Table 20 LVPECL Output Phase Noise with 25 MHz XTAL*..... | 31 |
| Table 21 LVDS Output Phase Noise with 25 MHz XTAL | 32 |
| Table 22 HCSL Output Phase Noise with 25 MHz XTAL | 32 |
| Table 23 7x7mm QFN Package Thermal Properties | 33 |

Pin Diagram

The device is packaged in a 7x7mm 48-pin QFN.

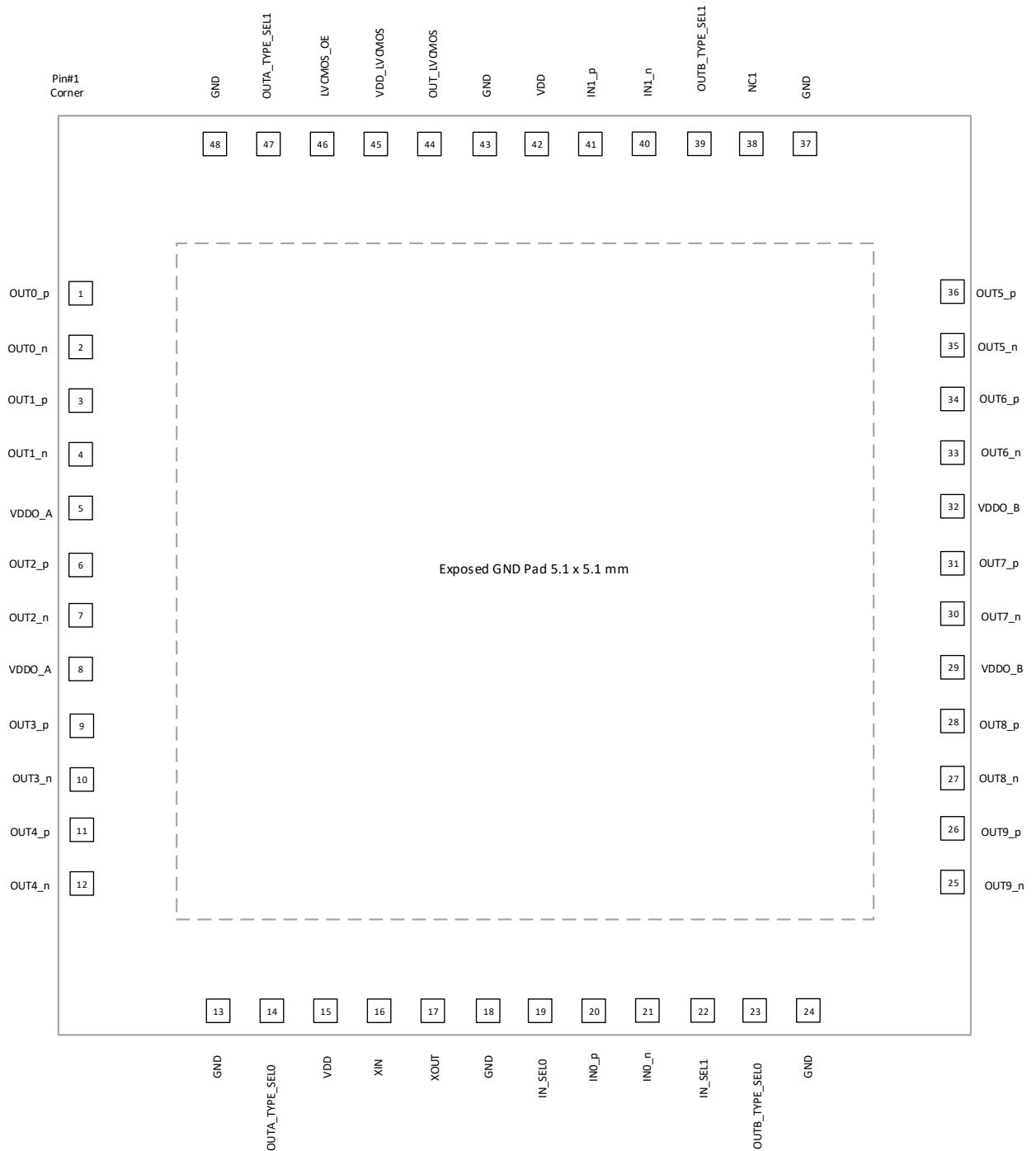

Figure 2. Pin Diagram

Pin Descriptions

All device inputs and outputs are LVPECL unless described otherwise. The I/O column uses the following symbols: I – input, I_{PU} – input with 300kΩ internal pull-up resistor, I_{PD} – input with 300kΩ internal pull-down resistor, I_{APU} – input with 31kΩ internal pull-up resistor, I_{APD} – input with 30kΩ internal pull-down resistor, I_{APU/APD} – input biased to VDD/2 with 60kΩ internal pull-up and pull-down resistors (30 kΩ equivalent), O – output, I/O – Input/Output pin, NC-No connect pin, P – power supply pin.

Table 1 Pin Descriptions

| # | Name | I/O | Description |
|---|--|--|---|
| Input Reference | | | |
| 20 21 41 40 | IN0_p IN0_n IN1_p IN1_n | I _{APD} I _{APU/APD} I _{APD} I _{APU/APD} | <p>Input Differential or Single Ended References 0 and 1</p> <p>Input frequency range 0Hz to 1.6GHz.</p> <p>Non inverting inputs (_p) are pulled down with internal 30kΩ pull-down resistors. Inverting inputs (_n) are pulled up and pulled down with 60kΩ internal resistors (30kΩ equivalent) to keep inverting input voltages at VDD/2 when inverting inputs are left floating (device fed with a single ended reference).</p> |
| Output Clocks | | | |
| 1 2 3 4 6 7 9 10 11 12 36 35 34 33 31 30 28 27 26 25 | OUT0_p OUT0_n OUT1_p OUT1_n OUT2_p OUT2_n OUT3_p OUT3_n OUT4_p OUT4_n OUT5_p OUT5_n OUT6_p OUT6_n OUT7_p OUT7_n OUT8_p OUT8_n OUT9_p OUT9_n | O | <p>Ultra Low Additive Jitter Differential LVPECL/HCSL/LVDS Outputs 0 to 9</p> <p>Output frequency range 0 to 1.6GHz</p> <p>Type (LVPECL/HCSL/LVDS/High-Z) of each output bank is controlled via OUTA/B_TYPE_SEL0/1 pins.</p> |
| 44 | OUT_LVCMOS | O | <p>Ultra Low Additive Jitter LVCMOS Output 0 to 9</p> <p>Output frequency range 0 to 250MHz</p> |

| Control | | | | | | | | | | | | | | | | | | |
|---------------------------|----------------------------------|--------------------|---|----------------|----------------|---------------|---|---|---------------|---|---|---------------|---|---|--------------------|---|---|-------------------|
| 19 22 | IN_SEL0 IN_SEL1 | I _{PD} | <p>Input select pins. Logic level on these pins selects which input will be passed to the output.</p> <table border="1"> <thead> <tr> <th>IN_SEL1</th> <th>IN_SEL0</th> <th>OUTN</th> </tr> </thead> <tbody> <tr> <td>0</td> <td>0</td> <td>Input 0 (IN0)</td> </tr> <tr> <td>0</td> <td>1</td> <td>Input 1 (IN1)</td> </tr> <tr> <td>1</td> <td>X</td> <td>Crystal Oscillator</td> </tr> </tbody> </table> | IN_SEL1 | IN_SEL0 | OUTN | 0 | 0 | Input 0 (IN0) | 0 | 1 | Input 1 (IN1) | 1 | X | Crystal Oscillator | | | |
| IN_SEL1 | IN_SEL0 | OUTN | | | | | | | | | | | | | | | | |
| 0 | 0 | Input 0 (IN0) | | | | | | | | | | | | | | | | |
| 0 | 1 | Input 1 (IN1) | | | | | | | | | | | | | | | | |
| 1 | X | Crystal Oscillator | | | | | | | | | | | | | | | | |
| 14 47 | OUTA_TYPE_SELO OUTA_TYPE_SEL1 | I _{PD} | <p>Output Signal for Bank A: Selects Type of the output for Bank A (Outputs 0 to 4)</p> <table border="1"> <thead> <tr> <th>OUTA_TYPE_SEL1</th> <th>OUTA_TYPE_SELO</th> <th>Output 0 to 4</th> </tr> </thead> <tbody> <tr> <td>0</td> <td>0</td> <td>LVPECL</td> </tr> <tr> <td>0</td> <td>1</td> <td>LVDS</td> </tr> <tr> <td>1</td> <td>0</td> <td>HCSL</td> </tr> <tr> <td>1</td> <td>1</td> <td>High-Z (Disabled)</td> </tr> </tbody> </table> | OUTA_TYPE_SEL1 | OUTA_TYPE_SELO | Output 0 to 4 | 0 | 0 | LVPECL | 0 | 1 | LVDS | 1 | 0 | HCSL | 1 | 1 | High-Z (Disabled) |
| OUTA_TYPE_SEL1 | OUTA_TYPE_SELO | Output 0 to 4 | | | | | | | | | | | | | | | | |
| 0 | 0 | LVPECL | | | | | | | | | | | | | | | | |
| 0 | 1 | LVDS | | | | | | | | | | | | | | | | |
| 1 | 0 | HCSL | | | | | | | | | | | | | | | | |
| 1 | 1 | High-Z (Disabled) | | | | | | | | | | | | | | | | |
| 23 39 | OUTB_TYPE_SELO OUTB_TYPE_SEL1 | I/O | <p>Output Signal for Bank B: Selects Type of the output for Bank B (Outputs 5 to 9)</p> <table border="1"> <thead> <tr> <th>OUTB_TYPE_SEL1</th> <th>OUTB_TYPE_SELO</th> <th>Output 5 to 9</th> </tr> </thead> <tbody> <tr> <td>0</td> <td>0</td> <td>LVPECL</td> </tr> <tr> <td>0</td> <td>1</td> <td>LVDS</td> </tr> <tr> <td>1</td> <td>0</td> <td>HCSL</td> </tr> <tr> <td>1</td> <td>1</td> <td>High-Z (Disabled)</td> </tr> </tbody> </table> | OUTB_TYPE_SEL1 | OUTB_TYPE_SELO | Output 5 to 9 | 0 | 0 | LVPECL | 0 | 1 | LVDS | 1 | 0 | HCSL | 1 | 1 | High-Z (Disabled) |
| OUTB_TYPE_SEL1 | OUTB_TYPE_SELO | Output 5 to 9 | | | | | | | | | | | | | | | | |
| 0 | 0 | LVPECL | | | | | | | | | | | | | | | | |
| 0 | 1 | LVDS | | | | | | | | | | | | | | | | |
| 1 | 0 | HCSL | | | | | | | | | | | | | | | | |
| 1 | 1 | High-Z (Disabled) | | | | | | | | | | | | | | | | |
| 46 | LVC MOS_OE | I | <p>Output enable for LVC MOS outputs: When high LVC MOS output is enabled. When low LVC MOS output is High-Z</p> | | | | | | | | | | | | | | | |
| Crystal Oscillator | | | | | | | | | | | | | | | | | | |
| 16 | XIN | I | <p>Crystal Oscillator Input or crystal bypass mode or crystal overdrive mode If crystal oscillator circuit is not used pull down this pin or connect it to ground.</p> | | | | | | | | | | | | | | | |
| 17 | XOUT | O | <p>Crystal Oscillator Output</p> | | | | | | | | | | | | | | | |

| No Connect | | | |
|----------------------------------|------------|----|---|
| 38 | NC1 | NC | No Connects (not connected to the die) Leave unconnected or connect to GND for mechanical support |
| Power and Ground | | | |
| 15 42 | VDD | P | Positive Supply Voltage. Connect to 3.3V or 2.5V supply. |
| 5 8 | VDDO_A | P | Positive Supply Voltage for Differential Outputs Bank A Connect 3.3V or 2.5V power supply. VDDO_A does not have to be connected to the same voltage level as VDD or VDDO_B. These pins power up differential outputs OUT[0:4]_p/n. |
| 29 32 | VDDO_B | | Positive Supply Voltage for Differential Outputs Bank B Connect 3.3V or 2.5V power supply. VDDO_B does not have to be connected to the same voltage level as VDD or VDDO_A. These pins power up differential outputs OUT[5:9]_p/n. |
| 45 | VDD_LVCMOS | P | Power Supply Voltage for LVCMOS Output Connect to 3.3V, 2.5V, 1.8V or 1.5V power supply |
| 13 18 24 43 37 48 | GND | P | Ground Connect to ground |
| E-Pad | GND | P | Ground. Connect to ground |

Functional Description

The ZL40231 is a low additive jitter, low power 3 x 10 LVPECL/HCSL/LVDS fanout buffer.

Two inputs can accept signal in differential (LVPECL, SSTL, LVDS, HSTL, CML) or single ended (LVPECL or LVCMOS) format and the third input can accept a single ended signal or it can be used to build a crystal oscillator by connecting an external crystal resonator between its XIN and XOUT pins.

The ZL40231 has ten LVPECL/HCSL/LVDS outputs which can be powered from 3.3V or 2.5V supply. Each output bank (A and B) can be independently set to be LVPECL, LVDS, HCSL or Hi-Z via control OUTA/B_TYPE_SEL0/1 pins.

The control inputs: OUTA/B_TYPE_SEL0/1 and IN_SEL0/1 have low input threshold voltage so they can be driven from a device with low I/O voltage (down to 1.2V).

The device operates from 2.5V+/-5% or 3.3V+/-5% supply. Its operation is guaranteed over the industrial temperature range -40°C to +85°C.

Clock Inputs

The following blocks diagram shows how to terminate different signals fed to the ZL40231 inputs.

Figure 3 shows how to terminate a single ended output such as LVCMOS. Ideally, resistors R1 and R2 should be 100Ω each and $R_o + R_s$ should be 50Ω so that the transmission line is terminated at both ends with characteristic impedance. If the driving strength of the output driver is not sufficient to drive low impedance, the value of series resistor R_s should be increased. This will reduce the voltage swing at the input but this should be fine as long as the input voltage swing requirement is not violated (Table 7). The source resistors of $R_s = 270\Omega$ could be used for standard LVCMOS driver. This will provide 516mV of voltage swing for 3.3V LVCMOS driver with load current of $(3.3V/2) * (1/(270\Omega + 50\Omega)) = 5.16mA$.

For optimum performance both differential input pins ($_p$ and $_n$) need to be DC biased to the same voltage. Hence, the ratio $R1/R2$ should be equal to the ratio $R3/R4$.

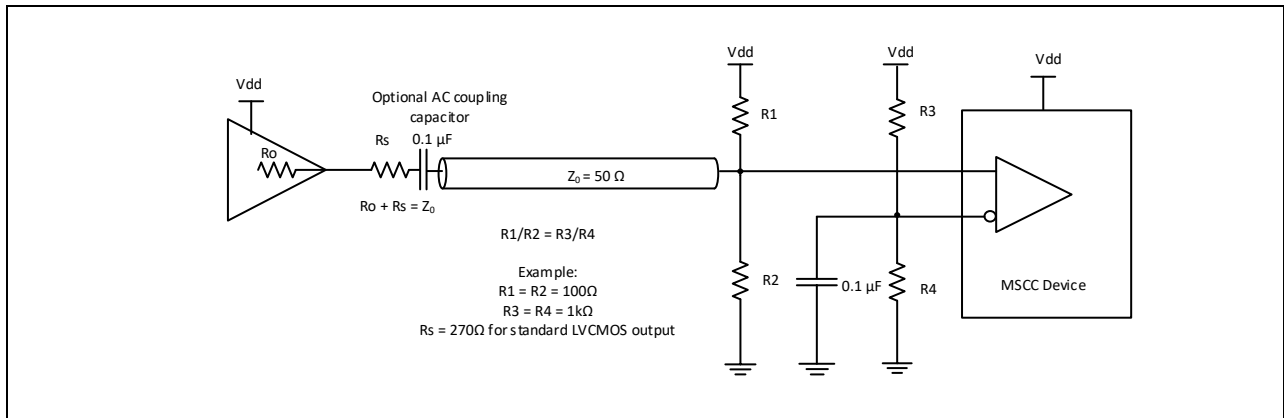

Figure 3. Input driven by a single ended output

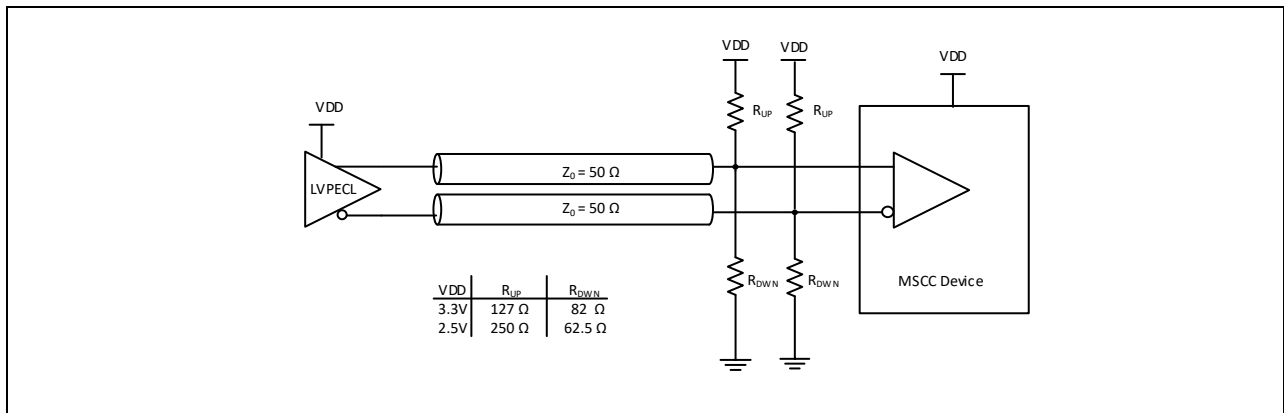

Figure 4. Input driven by DC coupled LVPECL output

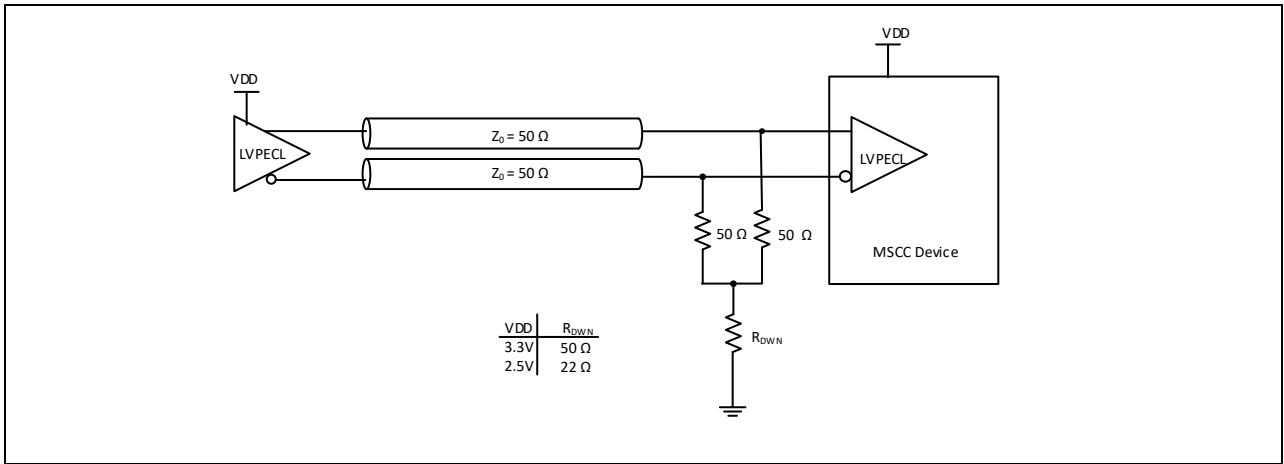

Figure 5. Input driven by DC coupled LVPECL output (alternative termination)

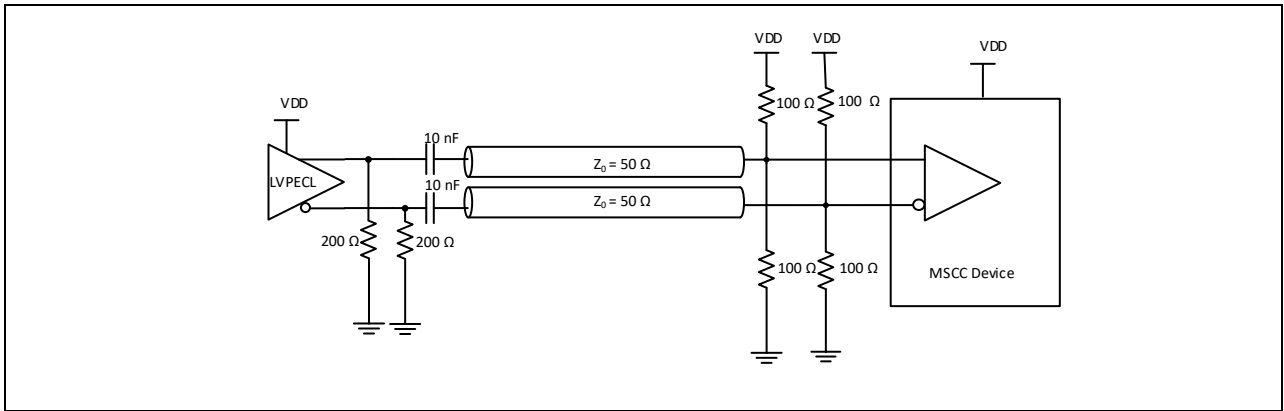

Figure 6. Input driven by AC coupled LVPECL output

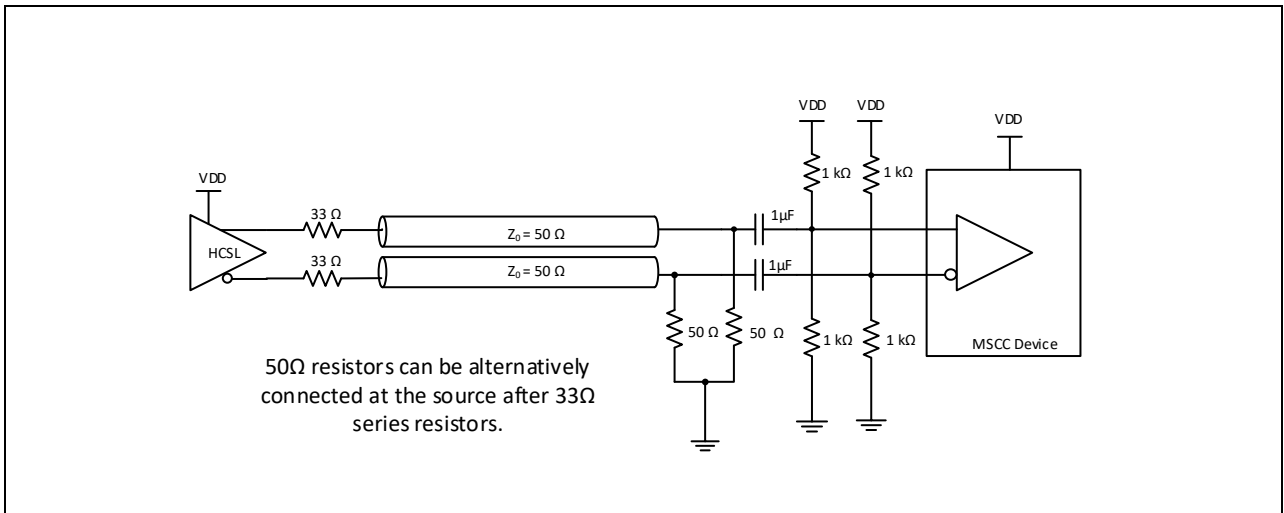

Figure 7. Input driven by HCSL output

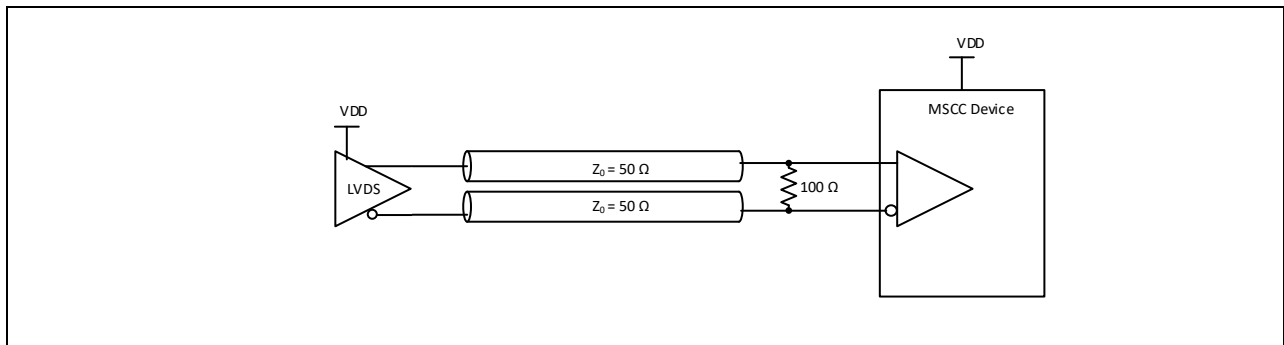

Figure 8. Input driven by LVDS output

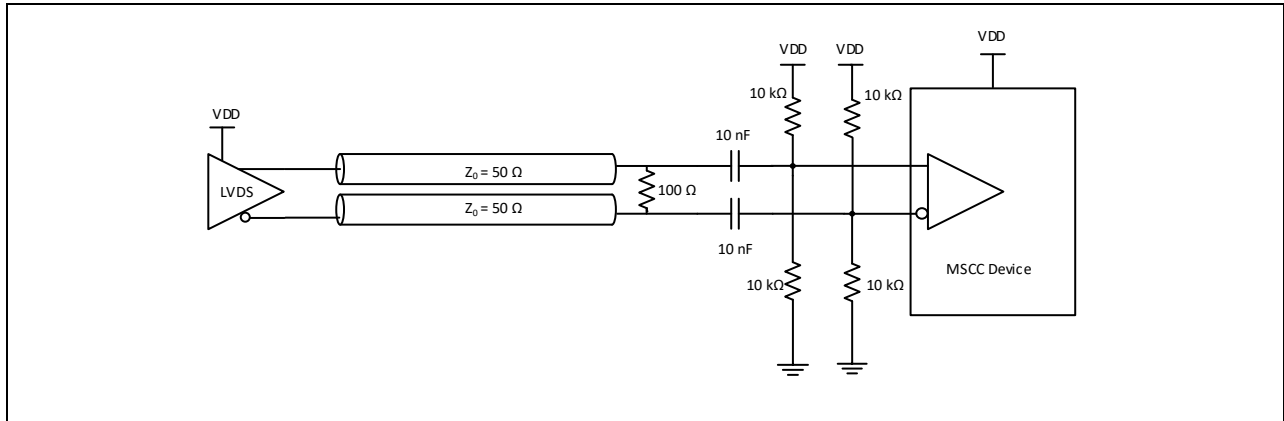

Figure 9. Input driven by AC coupled LVDS

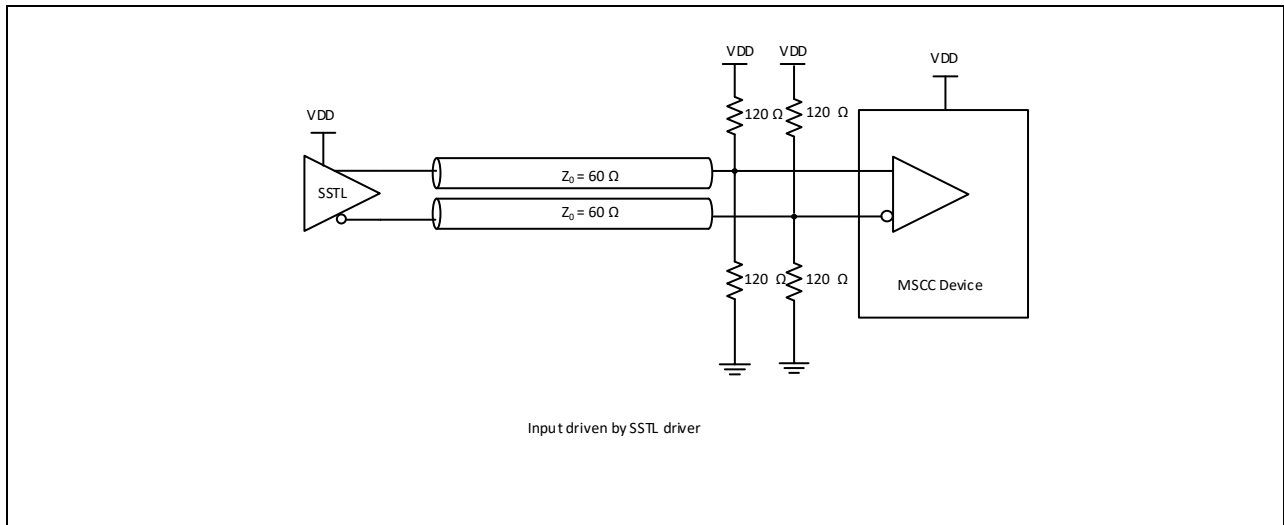

Figure 10. Input driven by an SSTL output

Clock Outputs

LVC MOS output OUT10 require only series termination resistor whose value is depending on LVC MOS output voltage as shown in Figure 11.

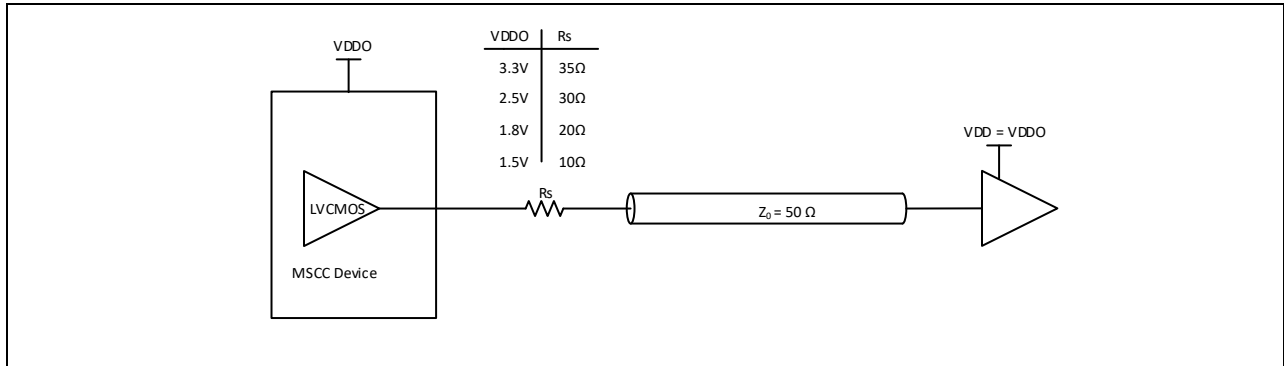

Figure 11. Termination for LVC MOS output

Differential outputs LVPECL and LVDS should have same termination as corresponding outputs described in previous section. HCSL outputs should be terminated with 33Ω series resistors at the source and 50Ω shunt resistors at the source or at the end on the transmission line. AC coupling and re-biasing is not required at the outputs when driving native HCSL receivers.

The device is designed to drive differential input of semiconductor devices. In applications that use a transformer to convert from the differential to the single ended output (for example driving an oscilloscope 50Ω input), a resistor larger than 10Ω should be added at the center tap of the primary winding to achieve optimum jitter performance as shown in Figure 12. This is to provide a nominal common mode impedance of 10Ω or higher which is typical for differential terminations.

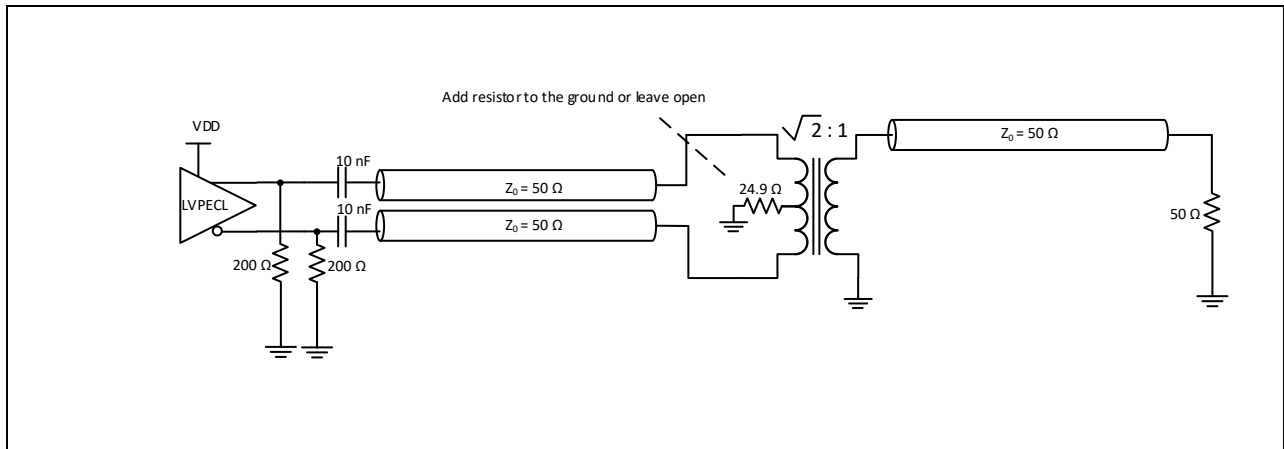

Figure 12. Driving a load via transformer

Crystal Oscillator Input

The crystal oscillator circuit can work with crystal resonators from 8MHz to 60MHz. Load capacitors C1, C2 and series resistor Rs shall be selected as per crystal vendor recommendation. Shunt resistor is implemented inside the device.

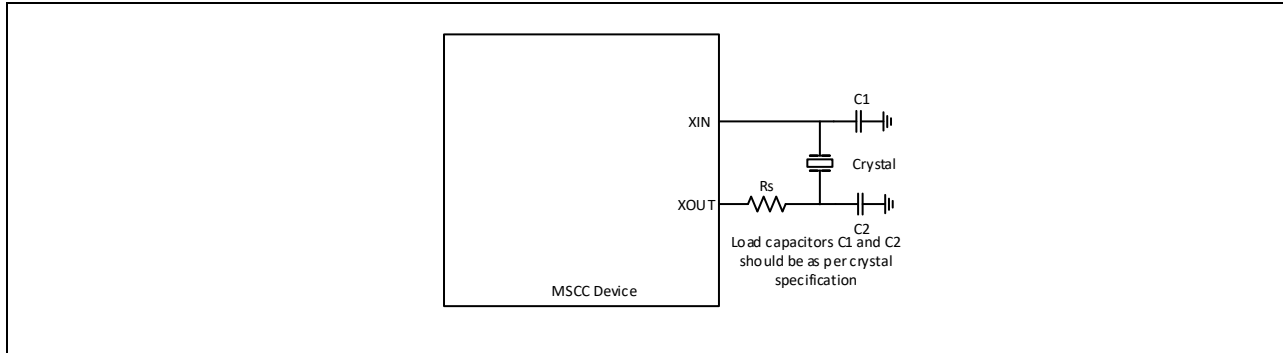

Figure 13. Crystal Oscillator Circuit

Termination of unused inputs and outputs

Unused inputs can be left unconnected or alternatively IN_0/1 can be pulled-down by 1kΩ resistor. Unused outputs should be left unconnected.

Power Consumption

The device total power consumption can be calculated as:

$$P_T = P_S + P_{XTAL} + P_C + P_{O_DIF} + P_{O_LVCMOS}$$

Where:

$$P_S = V_{DD} \times I_S$$

The core power when XTAL is not used. The current is specified in Table 6. If XTAL is running this power should be set to zero.

$$P_{XTAL} = V_{DD} \times I_{DD_XTAL}$$

The core power when XTAL is used. The current is provided in Table 6. If XTAL is not used this power should be set to zero.

$$P_C = V_{DDO} \times I_{DD_CM}$$

Common output power shared among all ten outputs. The current I_{DD_CM} is specified Table 6.

$$P_{O_DIF} = V_{DDO} \times I_{DD_LVDS} \times N$$

Output power where output current (I_{DD_LVDS}) is specified in Table 6. For LVPECL or HCSL just replace I_{DD_LVDS} with I_{DD_LVPECL} or I_{DD_HCSL} .

N is the number of enabled differential outputs and it can be either: 0, 5 or 10.

$$P_{O_LVCMOS} = V_{DD_LVCMOS} \times (I_{DD} \times f / 100MHz + V_{DD_LVCMOS} \times C_{LOAD} \times f)$$

Dynamic LVCMOS output power. I_{DD} is specified in Table 6. If LVCMOS output is disabled this term is equal to zero.

Power dissipated inside the device can be calculated by subtracting power dissipated in termination/biasing resistors from the power consumption.

$$P_D = P_T - N_1 \times P_{LVPECL} - N_2 \times P_{LVDS} - N_3 \times P_{HCSL}$$

Where N_1 , N_2 and N_3 are the number of enabled LVPECL, LVDS and HCSL outputs respectively. When both banks are enabled $N_1 + N_2 + N_3 = 10$ and one or two of N_1 , N_2 and N_3 will equal to 0.

$$P_{LVPECL} = (V_{OH} - V_B)^2 / 50\Omega + (V_{OL} - V_B)^2 / 50\Omega + (V_{OH} - V_B) \times V_B / 50\Omega + (V_{OL} - V_B) \times V_B / 50\Omega$$

V_{OH} and V_{OL} are the output high and low voltages respectively for LVPECL output

V_B is LVPECL bias voltage equal to $V_{DD} - 2V$

$$P_{LVDS} = V_{SW}^2 / 100\Omega$$

V_{SW} is voltage swing of LVDS output.

$$P_{HCSL} = (V_{SW} / 50\Omega)^2 \times (33\Omega + 50\Omega)$$

V_{SW} is voltage swing of HCSL output. 50Ω is termination resistance and 33Ω is series resistance of the HCSL output.

Power Supply Filtering

Each power pin (VDD and VDDO) should be decoupled with $0.1\mu\text{F}$ capacitor with minimum equivalent series resistance (ESR) and minimum series inductance (ESL). For example, 0402 X5R Ceramic Capacitors with 6.3V minimum rating could be used. These capacitors should be placed as close as possible to the power pins. To reduce the power noise from adjacent digital components on the board each power supply could be further insulated with low resistance ferrite bead with two capacitors. The ferrite bead will also insulate adjacent component from the noise generated from the device. Following figure shows recommended decoupling for each power pin.

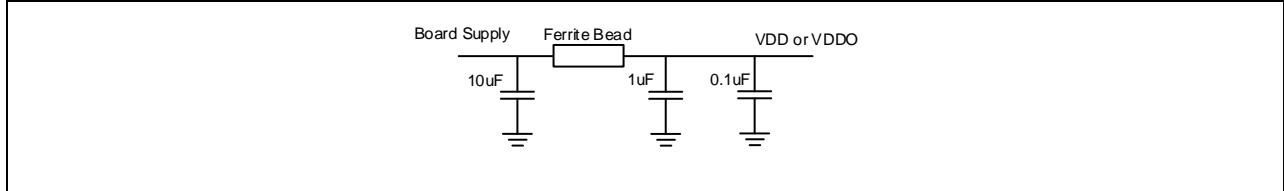

Figure 14. Power Supply Filtering

Power Supplies and Power-up Sequence

The device has four different power supplies: VDD, VDDO_A, VDDO_B and VDD_LVCMOS which are mutually independent. Voltages supported by each of these power supplies are specified in Table 1.

The device is not sensitive to the power-up sequence. For example, commonly used sequence where higher voltage comes up before or at the same time as the lower voltages can be used (or any other sequence).

Host Interface

ZL40231 is controlled via Input Select (IN_SEL0/1) pins which select which one of three inputs is fed to the output and show in Table 2 and OUTA/B_TYPE_SEL0/1 pins which select signal level (LVPECL, LVDS, HCSL or Hi-Z) for each of two (A and B) output banks as shown in Table 3.

All input control pins have low input threshold voltage so they can be driven from the device with low output voltage (FPGA/CPLD). Supported voltages are between 1.2V and VDD (2.5V or 3.3V).

Table 2 Input clock selection

| IN_SEL1 | IN_SEL0 | Selected Input |
|---------|---------|----------------|
| 0 | 0 | IN0_p, IN0_n |
| 0 | 1 | IN1_p, IN1_n |
| 1 | X | XIN |

Table 3 Output Type Selection

| OUTA/B_TYPE_SEL1 | OUTA/B_TYPE_SEL0 | Output |
|------------------|------------------|--------------------------|
| 0 | 0 | LVPECL |
| 0 | 1 | LVDS |
| 1 | 0 | HCSL |
| 1 | 1 | High-Z (Output Disabled) |

Typical device performance

The following plots show typical device performances

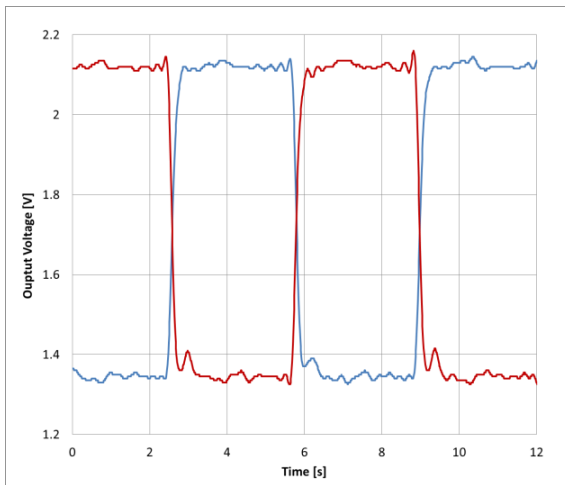

Figure 15. 156.25MHz LVPECL

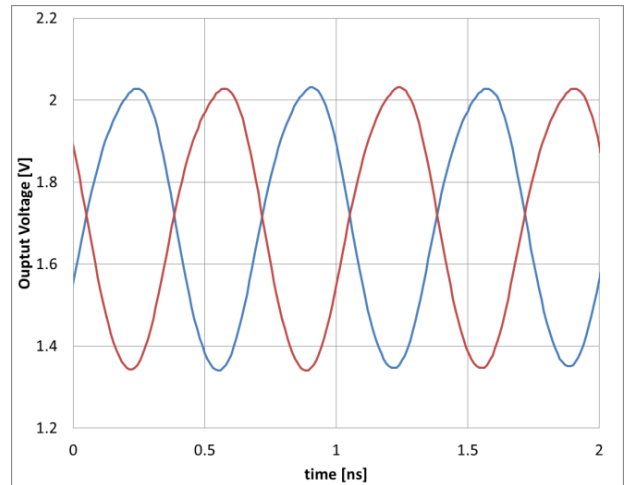

Figure 16. 1.5GHz LVPECL

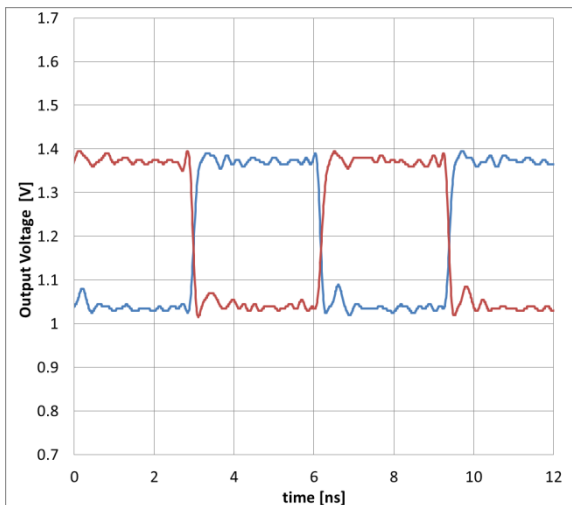

Figure 17. 156.25MHz LVDS

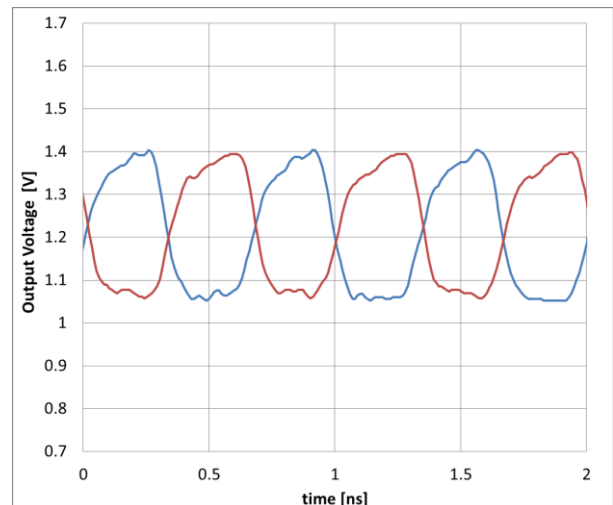

Figure 18. 1.5GHz LVDS

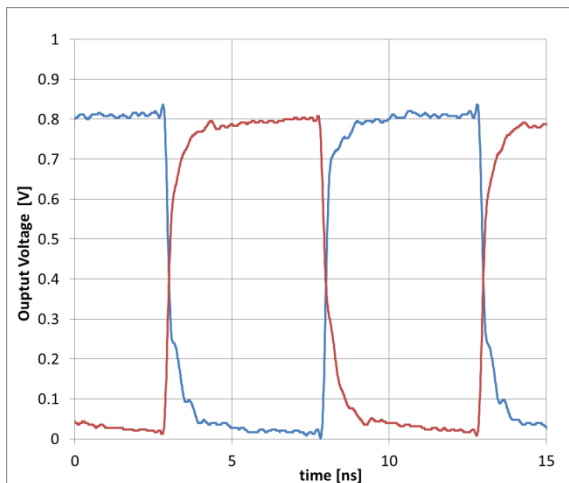

Figure 19. 100MHz HCSSL

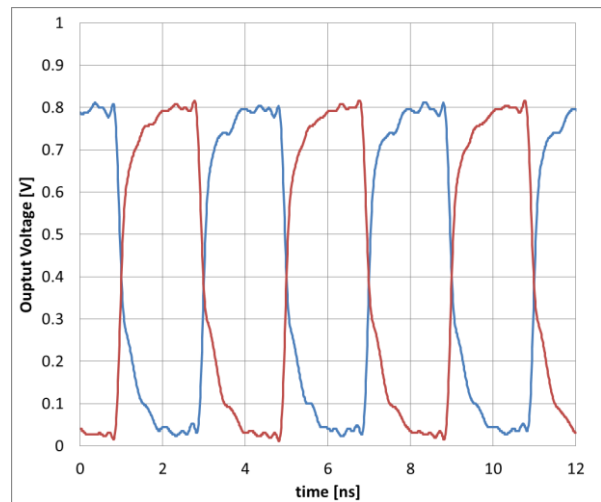

Figure 20. 250MHz HCSSL

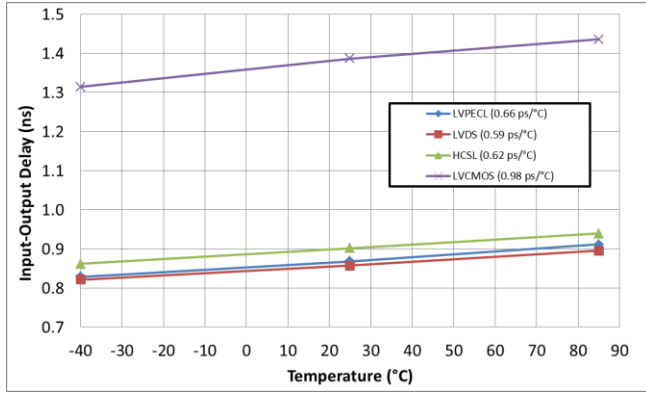

Figure 21. I/O delay vs temperature

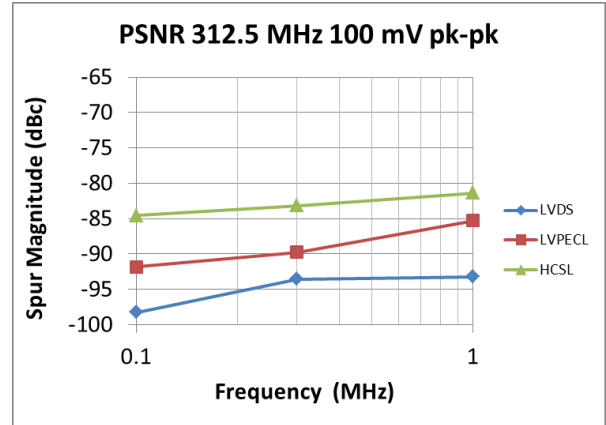

Figure 22. PSNR vs noise frequency

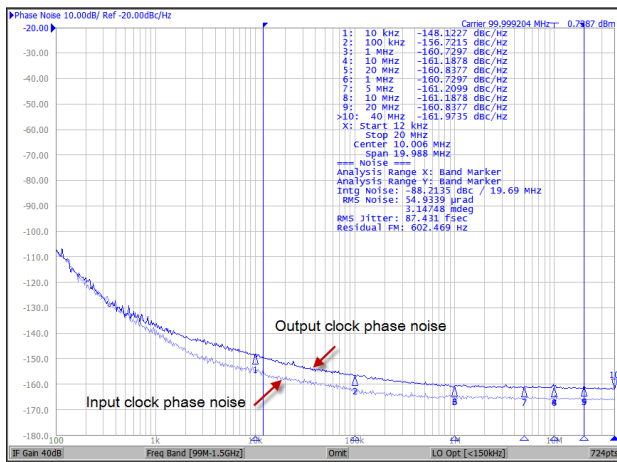

Figure 23. 100MHz LVPECL Phase Noise

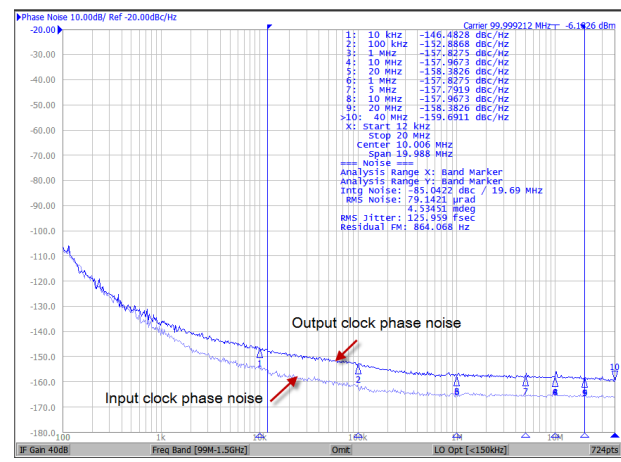

Figure 24. 100MHz LVDS Phase Noise

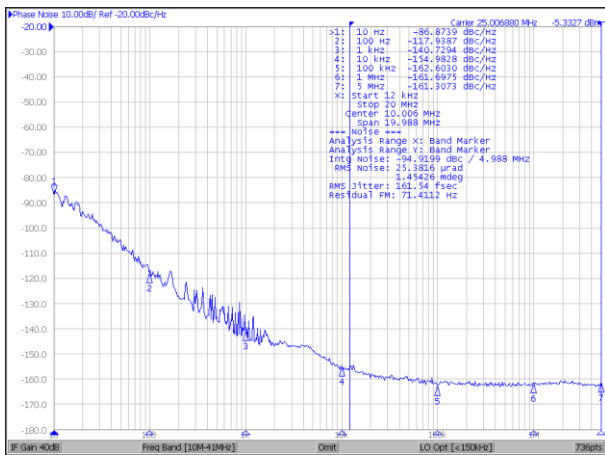

Figure 25. 25MHz LVDS Phase Noise in Xtal mode

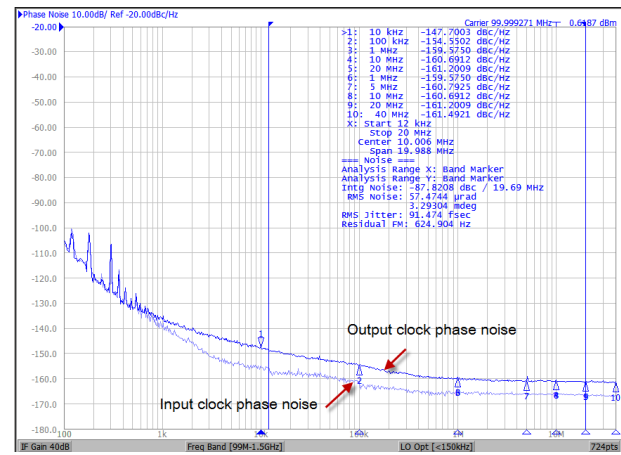

Figure 26. 100MHz HCSL Phase Noise

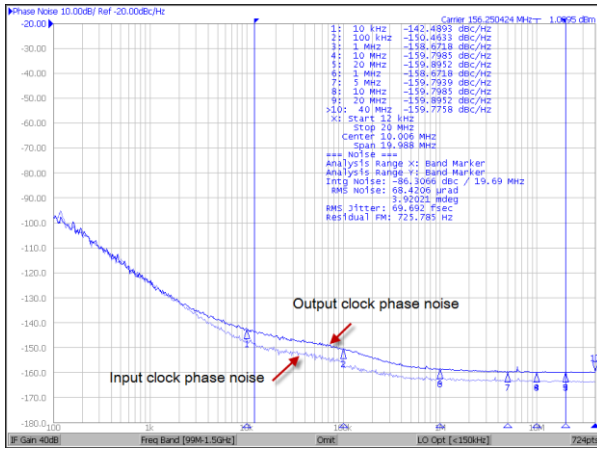

Figure 27. 156.25MHz LVPECL Phase Noise

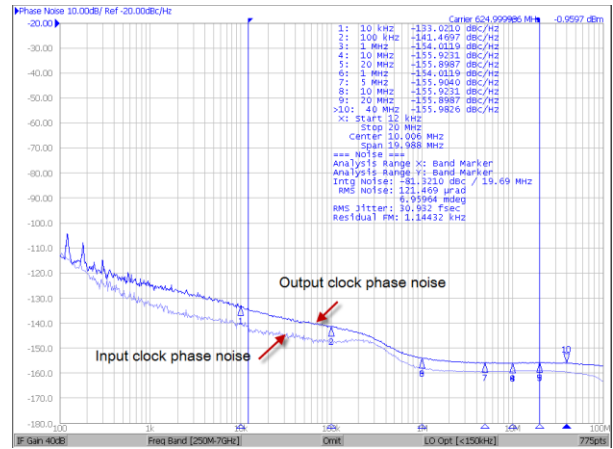

Figure 28. 625MHz LVPECL Phase Noise

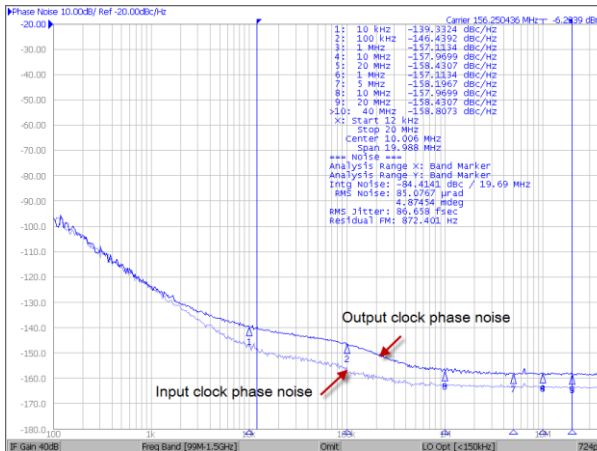

Figure 29. 156.25MHz LVDS Phase Noise

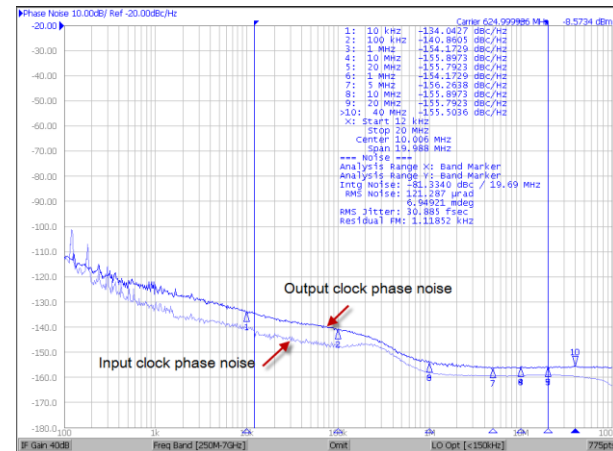

Figure 30. 625MHz LVDS Phase Noise

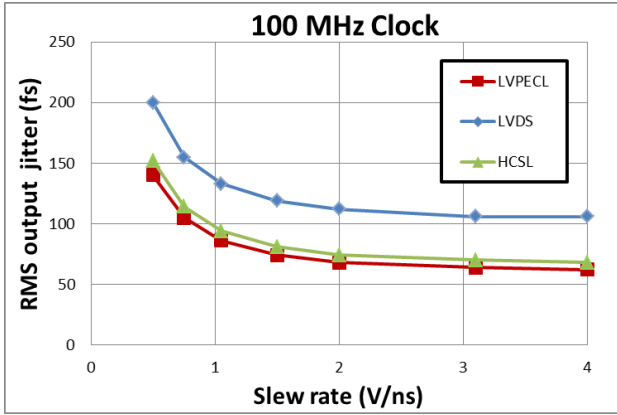

Figure 31. Output RMS jitter (12kHz to 20MHz) vs input clock slew-rate

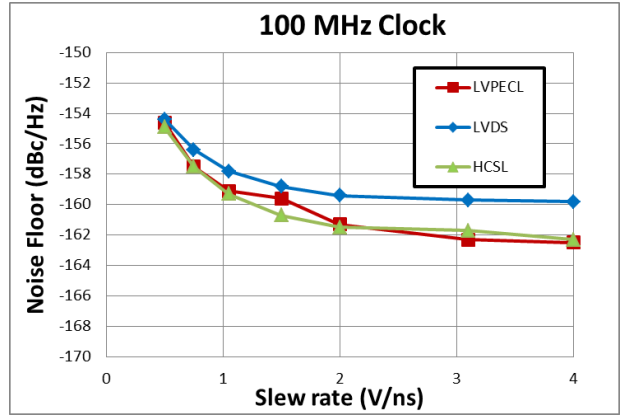

Figure 32. Output clock noise floor vs input clock slew-rate

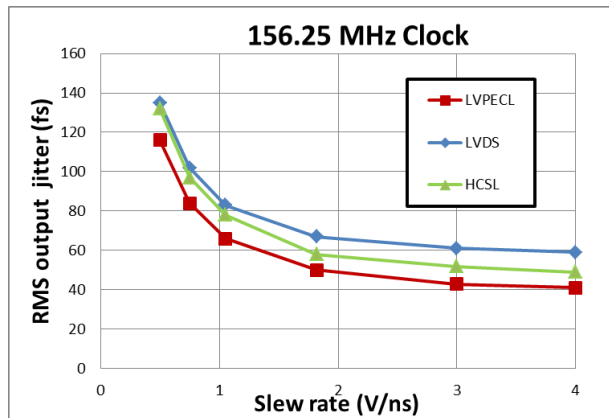

Figure 33. Output RMS jitter (12kHz to 20MHz) vs input clock slew-rate

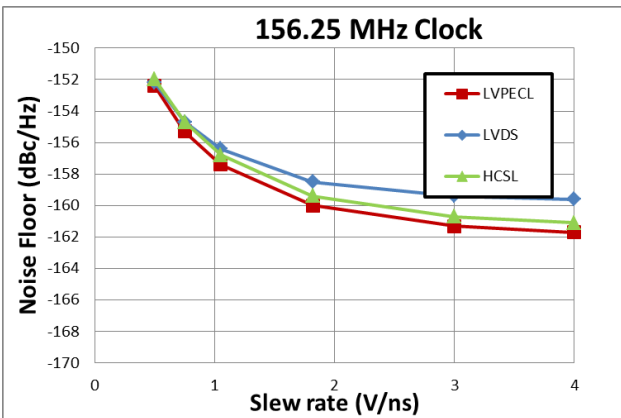

Figure 34. Output clock noise floor vs input clock slew-rate

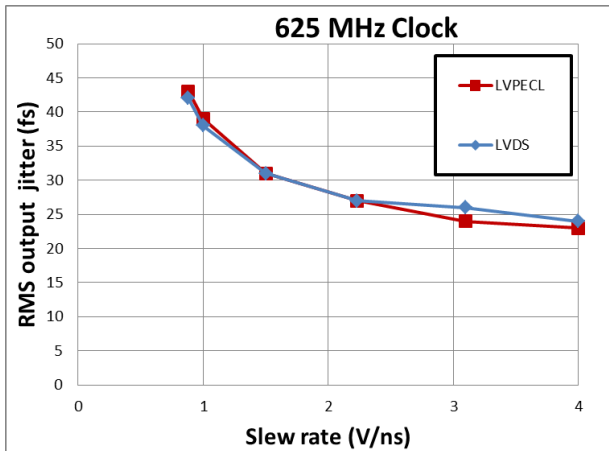

Figure 35. Output RMS jitter (12kHz to 20MHz) vs input clock slew-rate

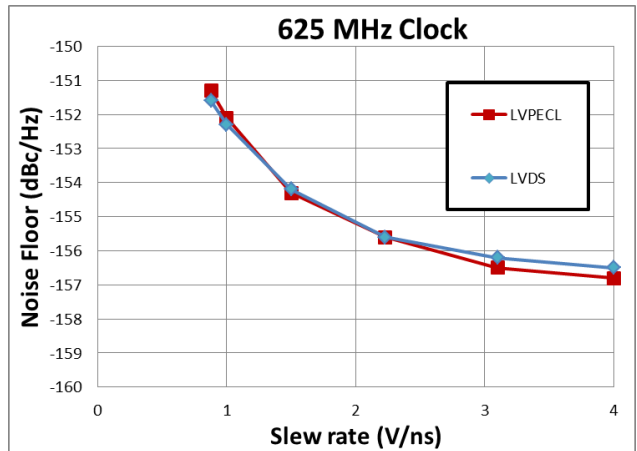

Figure 36. Output clock noise floor vs input clock slew-rate

AC and DC Electrical Characteristics

Absolute Maximum Ratings

Table 4 Absolute Maximum Ratings*

| | Parameter | Sym. | Min. | Typ. | Max. | Units | Notes |
|---|-----------------------|------------------|------|------|------|-------|-------|
| 1 | Supply voltage (3.3V) | V_{DD}/V_{DDO} | -0.5 | | 4.6 | V | |
| 2 | Supply voltage (2.5V) | V_{DD}/V_{DDO} | -0.5 | | 3.5 | V | |
| 3 | Storage temperature | T_{ST} | -55 | | 125 | °C | |

* Exceeding these values may cause permanent damage

* Functional operation under these conditions is not implied

* Voltages are with respect to ground (GND) unless otherwise stated

Recommended Operating Conditions

Table 5 Recommended Operating Conditions*

| | Characteristics | Sym. | Min. | Typ. | Max. | Units | Notes |
|---|-----------------------|----------------------------------|-------|------|----------------|-------|-------|
| 1 | Supply voltage 3.3V | $V_{DD}/V_{DDO}/V_{DD_LVC MOS}$ | 3.135 | 3.30 | 3.465 | V | |
| 2 | Supply voltage 2.5V | $V_{DD}/V_{DDO}/V_{DD_LVC MOS}$ | 2.375 | 2.50 | 2.625 | V | |
| 3 | Supply voltage 1.8V | $V_{DD_LVC MOS}$ | 1.6 | 1.8V | 2 | V | |
| 4 | Supply voltage 1.5V | $V_{DD_LVC MOS}$ | 1.35 | 1.5 | 1.65 | V | |
| 5 | Operating temperature | T_A | -40 | 25 | 85 | °C | |
| 6 | Input voltage | V_{DD-IN} | - 0.3 | | $V_{DD} + 0.3$ | V | |

* Voltages are with respect to ground (GND) unless otherwise stated

* The device core supports two power supply modes (3.3V and 2.5V)

Table 6 Current consumption

| | Characteristics | Sym. | Min. | Typ. | Max. | Units | Notes |
|---|---|------------------------|------|-------|-------|-------|------------------------|
| 1 | Core device current (all outputs and XTAL disabled) | $I_{s_3.3V}$ | | 163 | 197 | mA | $V_{DD} = 3.3V + 5\%$ |
| | | $I_{s_2.5V}$ | | 153 | 187 | mA | $V_{DD} = 2.5V + 5\%$ |
| 2 | Core device current (all outputs disabled) XTAL circuit enabled with 25MHz Crystal connected between XIN and XOUT | $I_{DD_XTAL_3.3V}$ | | 128 | 154 | mA | $V_{DD} = 3.3V + 5\%$ |
| | | $I_{DD_XTAL_2.5V}$ | | 124 | 150 | mA | $V_{DD} = 2.5V + 5\%$ |
| 3 | Common output current | $I_{DD_CM_3.3V}$ | | 13.44 | 15.05 | mA | $V_{DDO} = 3.3V + 5\%$ |
| | | $I_{DD_CM_2.5V}$ | | 12.18 | 13.65 | mA | $V_{DDO} = 2.5V + 5\%$ |
| 4 | Dynamic LVC MOS output current (f = 100MHz) Needs to be scaled for different frequencies by f/100MHz | $I_{DD_3.3V}$ | | 2.38 | 2.68 | mA | $V_{DDO} = 3.3V + 5\%$ |
| | | $I_{DD_2.5V}$ | | 1.74 | 1.96 | mA | $V_{DDO} = 2.5V + 5\%$ |
| 5 | Current dissipation per LVEPCL output | $I_{DD_LVPECL_3.3V}$ | | 19.36 | 23.26 | mA | $V_{DDO} = 3.3V + 5\%$ |
| | | $I_{DD_LVPECL_2.5V}$ | | 19.38 | 22.17 | mA | $V_{DDO} = 2.5V + 5\%$ |
| 6 | Current dissipation per LVDS output | $I_{DD_LVDSL_3.3V}$ | | 6.73 | 8.00 | mA | $V_{DDO} = 3.3V + 5\%$ |
| | | $I_{DD_LVDS_2.5V}$ | | 6.87 | 7.83 | mA | $V_{DDO} = 2.5V + 5\%$ |
| 7 | Current dissipation per HC SL output | $I_{DD_HC SL_3.3V}$ | | 16.43 | 19.87 | mA | $V_{DDO} = 3.3V + 5\%$ |
| | | $I_{DD_HC SL_2.5V}$ | | 17.14 | 19.18 | mA | $V_{DDO} = 2.5V + 5\%$ |

Table 7 Input Characteristics*

| | Characteristics | Sym. | Min. | Typ. | Max. | Units | Notes |
|----|--|-----------------|------|--------------|------|---------|---------------------------|
| 1 | CMOS high-level input voltage for control inputs | V_{CIH} | 1.05 | | | V | |
| 2 | CMOS low-level input voltage for control inputs | V_{CIL} | | | 0.45 | V | |
| 3 | CMOS input leakage current for control inputs (includes current due to pull down resistors) | I_{IL} | -25 | | 50 | μA | $V_i = V_{DD}$ or 0 V |
| 4 | Differential input common mode voltage for IN0_p/n and IN1_p/n | V_{CM} | 1 | | 2 | V | |
| 5 | Differential input voltage difference for IN0_p/n and IN1_p/n $f \leq 1GHz$ ** | V_{ID} | 0.15 | | 1.3 | V | |
| 6 | Differential input voltage difference for IN0_p/n and IN1_p/n for $1GHz < f \leq 1.6GHz$ ** | V_{ID} | 0.35 | | 1.3 | V | |
| 7 | Differential input leakage current for IN0_p/n and IN1_p/n (includes current due to pull-up and pull-down resistors) | I_{IL} | -150 | | 150 | μA | $V_i = 2V$ or 0V |
| 8 | Single ended input voltage for IN0_p and IN1_p | V_{SI} | -0.3 | | 2.7 | V | $V_{DD} = 3.3V$ or $2.5V$ |
| 9 | Single ended input common mode voltage (IN0_p/n and IN1_p/n) | V_{SIC} | 1 | | 2 | V | $V_{DD} = 3.3V$ or $2.5V$ |
| 10 | Single ended input voltage swing for IN0_p and IN1_p | V_{SID} | 0.3 | | 1.3 | V | $V_{DD} = 3.3V$ or $2.5V$ |
| 11 | Input frequency (differential) | f_{IN} | 0 | | 1600 | MHz | |
| 12 | Input frequency (LVCMOS) | f_{IN_CMOS} | 0 | | 250 | MHz | |
| 13 | Input duty cycle | dc | 35% | | 65% | | |
| 14 | Input slew rate | slew | | 2 | | V/ns | |
| 15 | Input pull-up/ pull-down resistance | R_{PU}/R_{PD} | | 60k Ω | | | |
| 16 | Input pull-down resistance for INx_p | R_{PD} | | 30k Ω | | | |
| 17 | Input multiplexer isolation IN0_p/n to IN1_p/n and vice versa Power on both inputs 0dBm, $f_{OFFSET} > 50kHz$ | Iso | | -84 | | dBc | $f_{IN} = 100$ MHz |
| | | | | -82 | | | $f_{IN} = 200$ MHz |
| | | | | -71 | | | $f_{IN} = 400$ MHz |
| | | | | -67 | | | $f_{IN} = 800$ MHz |

* Values are over Recommended Operating Conditions

* Values are over all two power supply modes ($V_{DD} = 3.3V$ and $V_{DD} = 2.5V$)

* Input mux isolation is measured as amplitude of f_{OFFSET} spur in dBc on the output clock phase noise plot

**Input differential voltage is calculated as $V_{ID} = V_{IH} - V_{IL}$ where V_{IH} and V_{IL} are input voltage high and low respectively. It should not be confused with $V_{ID} = 2 * (V_{IH} - V_{IL})$ used in some datasheets. Please refer to Figure 37.

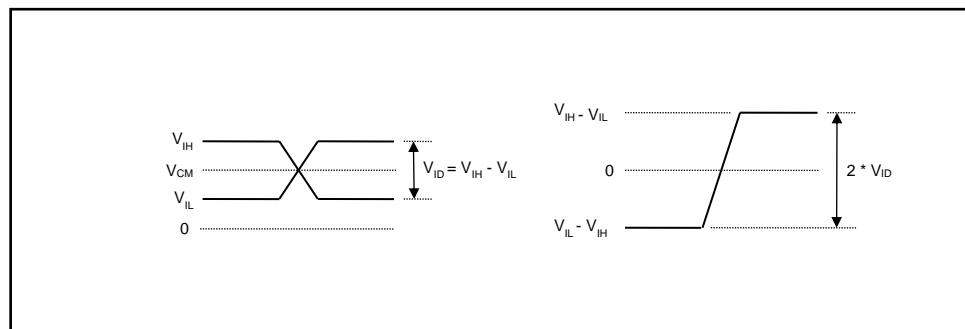

Figure 37. Differential Input Voltage Levels

Table 8 Crystal Oscillator Characteristics*

| | Characteristics | Sym. | Min. | Typ. | Max. | Units | Notes |
|---|--|-----------------|-------------|------|------|------------|---|
| 1 | Mode of oscillation | mode | Fundamental | | | | |
| 2 | Frequency | f | 8 | | 60 | MHz | |
| 3 | On chip load capacitance | | | 1 | | pF | |
| 4 | On chip series resistor | | | 0 | | Ω | |
| 5 | On chip shunt resistor | R | | 500 | | k Ω | |
| 6 | Frequency in overdrive mode ⁽¹⁾ | f _{OV} | 0.1 | | 250 | MHz | Functional but may not meet AC parameters Minimum depends on AC coupling Capacitor (0.1 μ F assumed) |
| 7 | Frequency in bypass mode ⁽²⁾ | f _{BP} | 0 | | 250 | MHz | Functional but may not meet AC parameters |

* Values are over Recommended Operating Conditions

* Values are over all two power supply modes ($V_{DD} = 3.3V$ and $V_{DD} = 2.5V$)

(1) Maximum input level is 2V

(2) Maximum output level is VDD

Table 9 Power Supply Rejection Ratio for VDD = VDDO = 3.3V*

| | Characteristics | Sym. | Min. | Typ. | Max. | Units | Notes |
|---|------------------------|------------------------|------|--------|------|-------|------------------------------|
| 1 | PSRR for LVPECL output | PSRR _{LVPECL} | | -71.75 | | dBc | f _{IN} = 156.25 MHz |
| | | | | -84.45 | | | f _{IN} = 312.5 MHz |
| | | | | -82.11 | | | f _{IN} = 625 MHz |
| 2 | PSRR for LVDS output | PSRR _{LVDS} | | -95.16 | | dBc | f _{IN} = 156.25 MHz |
| | | | | -97.77 | | | f _{IN} = 312.5 MHz |
| | | | | -79.23 | | | f _{IN} = 625 MHz |
| 3 | PSRR for HCSSL output | PSRR _{HCSSL} | | -77.15 | | dBc | f _{IN} = 100 MHz |
| | | | | -76.75 | | | f _{IN} = 156.25 MHz |
| | | | | -80.44 | | | f _{IN} = 312.5 MHz |

* Values are over Recommended Operating Conditions

* Noise injected to VDDO power supply with frequency 100 kHz and amplitude 100 mVpp

* PSRR is measured as amplitude of 100 kHz spur in dBc on the output clock phase noise plot

Table 10 Power Supply Rejection Ratio for VDD = VDDO = 2.5V*

| | Characteristics | Sym. | Min. | Typ. | Max. | Units | Notes |
|---|------------------------|------------------------|------|--------|------|-------|------------------------------|
| 1 | PSRR for LVPECL output | PSRR _{LVPECL} | | -73.68 | | dBc | f _{IN} = 156.25 MHz |
| | | | | -78.88 | | | f _{IN} = 312.5 MHz |
| | | | | -71.82 | | | f _{IN} = 625 MHz |
| 2 | PSRR for LVDS output | PSRR _{LVDS} | | -90.04 | | dBc | f _{IN} = 156.25 MHz |
| | | | | -79.99 | | | f _{IN} = 312.5 MHz |
| | | | | -73.45 | | | f _{IN} = 625 MHz |
| 3 | PSRR for HCSL output | PSRR _{HCSL} | | -92.16 | | dBc | f _{IN} = 100 MHz |
| | | | | -74.08 | | | f _{IN} = 156.25 MHz |
| | | | | -91.88 | | | f _{IN} = 312.5 MHz |

* Values are over Recommended Operating Conditions

* Noise injected to VDDO power supply with frequency 100 kHz and amplitude 100 mVpp

* PSRR is measured as amplitude of 100 kHz spur in dBc on the output clock phase noise plot

Table 11 LVCMOS Output Characteristics for VDDO = 3.3V*

| | Characteristics | Sym. | Min. | Typ. | Max. | Units | Notes |
|----|--|------------------------|----------|------|------|--------|-------------------------|
| 1 | Output high voltage (1mA load) | V _{OH} | VDDO-0.1 | | | V | DC Measurement |
| 2 | Output low voltage (1mA load) | V _{OL} | | | 0.1 | V | DC Measurement |
| 3 | Output High Current (Load adjusted to Vout = VDDO/2) | I _{OH} | | 30 | | mA | DC Measurement |
| 4 | Output Low Current (Load adjusted to Vout = VDDO/2) | I _{OL} | | 34 | | mA | DC Measurement |
| 5 | Output impedance | R _O | | 15 | | Ω | DC Measurement |
| 6 | Rise time (20% to 80%) | t _r | | 220 | 310 | ps | |
| 7 | Fall time (20% to 80%) | t _f | | 320 | 365 | ps | |
| 8 | Output frequency | F _O | 0 | | 250 | MHz | |
| 9 | Input to output delay | t _{IOD} | 1.07 | 1.28 | 2.07 | ns | |
| 10 | Output enable time | t _{EN} | | | 3 | cycles | |
| 11 | Output disable time | T _{DIS} | | | 3 | cycles | |
| 12 | Additive RMS jitter in 1MHz to 5MHz band | T _{J,1M,5M} | | 46 | 80 | fs | Input Clock 25MHz |
| 13 | Additive RMS jitter in 12kHz to 5MHz band | T _{J,12K,5M} | | 56 | 90 | fs | Input Clock 25MHz |
| 14 | Additive RMS jitter in 1MHz to 20MHz band | T _{J,1M,20M} | | 60 | 79 | fs | Input Clock 125MHz |
| 15 | Additive RMS jitter in 12kHz to 20MHz band | T _{J,12K,20M} | | 65 | 86 | fs | Input Clock 125MHz |
| 16 | Additive RMS jitter in 1MHz to 20MHz band | T _{J,1M,20M} | | 61 | 94 | fs | Input Clock 156.25MHz |
| 17 | Additive RMS jitter in 12kHz to 20MHz band | T _{J,12K,20M} | | 66 | 100 | fs | Input Clock 156.25MHz |
| 18 | Noise floor | N _F | | -165 | -162 | dBc/Hz | Input clock: 25 MHz |
| 19 | | | | -160 | -156 | dBc/Hz | Input clock: 125 MHz |
| 20 | | | | -158 | -153 | dBc/Hz | Input clock: 156.25 MHz |

* Values are over Recommended Operating Conditions

Table 12 LVCMOS Output Characteristics for VDDO = 2.5V*

| | Characteristics | Sym. | Min. | Typ. | Max. | Units | Notes |
|----|--|-----------------|----------|------|------|----------|-------------------------|
| 1 | Output high voltage (1mA load) | V_{OH} | VDDO-0.1 | | | V | DC Measurement |
| 2 | Output low voltage (1mA load) | V_{OL} | | | 0.1 | V | DC Measurement |
| 3 | Output High Current (Load adjusted to $V_{out} = VDDO/2$) | I_{OH} | | 21 | | mA | DC Measurement |
| 4 | Output Low Current (Load adjusted to $V_{out} = VDDO/2$) | I_{OL} | | 25 | | mA | DC Measurement |
| 5 | Output impedance | R_o | | 15 | | Ω | DC Measurement |
| 6 | Rise time (20% to 80%) | t_r | | 225 | 310 | ps | |
| 7 | Fall time (20% to 80%) | t_f | | 320 | 365 | ps | |
| 8 | Output frequency | F_o | 0 | | 250 | MHz | |
| 9 | Input to output delay | t_{iod} | 1.10 | 1.41 | 2.30 | ns | |
| 10 | Output enable time | t_{EN} | | | 3 | cycles | |
| 11 | Output disable time | T_{DIS} | | | 3 | cycles | |
| 12 | Additive RMS jitter in 1MHz to 5MHz band | $T_{j,1M,5M}$ | | 51 | 104 | fs | Input Clock 25MHz |
| 13 | Additive RMS jitter in 12kHz to 5MHz band | $T_{j,12k,5M}$ | | 62 | 111 | fs | Input Clock 25MHz |
| 14 | Additive RMS jitter in 1MHz to 20MHz band | $T_{j,1M,20M}$ | | 64 | 81 | fs | Input Clock 125MHz |
| 15 | Additive RMS jitter in 12kHz to 20MHz band | $T_{j,12k,20M}$ | | 70 | 88 | fs | Input Clock 125MHz |
| 16 | Additive RMS jitter in 1MHz to 20MHz band | $T_{j,1M,20M}$ | | 62 | 94 | fs | Input Clock 156.25MHz |
| 17 | Additive RMS jitter in 12kHz to 20MHz band | $T_{j,12k,20M}$ | | 68 | 100 | fs | Input Clock 156.25MHz |
| 18 | Noise floor | N_F | | -164 | -161 | dBc/Hz | Input clock: 25 MHz |
| 19 | | | | -159 | -155 | dBc/Hz | Input clock: 125 MHz |
| 20 | | | | -158 | -153 | dBc/Hz | Input clock: 156.25 MHz |

* Values are over Recommended Operating Conditions

Table 13 LVPECL Output Characteristics for VDDO = 3.3V*

| | Characteristics | Sym. | Min. | Typ. | Max. | Units | Notes |
|----|---|-------------------------|------|------|------|--------|-------------------------|
| 1 | Output high voltage | V_{LVPECL_OH} | 1.9 | 2.08 | 2.4 | V | DC Measurement |
| 2 | Output low voltage | V_{LVPECL_OL} | 1.2 | 1.36 | 1.7 | V | DC Measurement |
| 3 | Output differential swing** | V_{LVPECL_SW} | 0.6 | 0.72 | 0.9 | V | DC Measurement |
| 4 | Variation of V_{LVPECL_SW} for complementary output states | ΔV_{LVPECL_SW} | 0 | 0.02 | 0.07 | V | |
| 5 | Common mode output | V_{CM} | 1.6 | 1.72 | 2.1 | V | |
| 7 | Output frequency when $V_{LVPECL_SW} \geq 0.6V$ | $F_{MAX_0.6VSW}$ | | | 800 | MHz | |
| 8 | Output frequency when $V_{LVPECL_SW} \geq 0.4V$ | $F_{MAX_0.4VSW}$ | | | 1600 | MHz | |
| 9 | Rise or fall time (20% to 80%) | t_r, t_f | | 110 | 170 | ps | |
| 10 | Output frequency | F_o | 0 | | 1600 | MHz | |
| 11 | Output to output skew | t_{OOSK} | | | 40 | ps | |
| 12 | Device to device output skew | t_{DOOSK} | | | 120 | ps | |
| 13 | Input to output delay | t_{IOD} | 0.73 | 0.87 | 1.1 | ns | |
| 14 | Output enable time | t_{EN} | | | 3 | cycles | |
| 15 | Output disable time | t_{DIS} | | | 3 | cycles | |
| 16 | Additive RMS jitter in 1MHz to 20MHz band | $T_{J_1M_20M}$ | | 68 | 96 | fs | Input clock: 100 MHz |
| | | | | 50 | 64 | fs | Input clock: 156.25MHz |
| | | | | 20 | 32 | fs | Input clock: 625 MHz |
| 17 | Additive RMS jitter in 12kHz to 20MHz band | $T_{J_12k_20M}$ | | 71 | 101 | fs | Input clock: 100 MHz |
| | | | | 55 | 70 | fs | Input clock: 156.25MHz |
| | | | | 25 | 39 | fs | Input clock: 625 MHz |
| 18 | Noise floor | N_F | | -161 | -159 | dBc/Hz | Input clock: 100 MHz |
| | | | | -160 | -155 | dBc/Hz | Input clock: 156.25 MHz |
| | | | | -155 | -151 | dBc/Hz | Input clock: 625 MHz |

* Values are over Recommended Operating Conditions

**Output differential swing is calculated as $V_{SW} = V_{OH} - V_{OL}$. It should not be confused with $V_{SW} = 2 * (V_{OH} - V_{OL})$ used in some datasheets. Please refer to Figure 38.

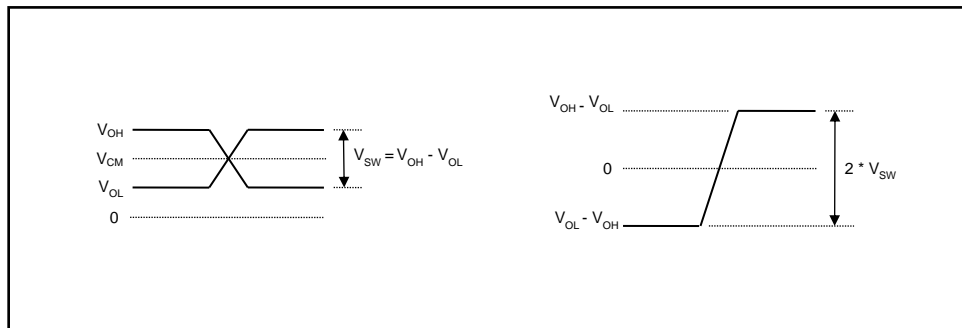

Figure 38. Differential Output Voltage Levels

Table 14 LVPECL Output Characteristics for VDDO = 2.5V*

| | Characteristics | Sym. | Min. | Typ. | Max. | Units | Notes |
|----|---|-------------------------|------|------|------|--------|-------------------------|
| 1 | Output high voltage | V_{LVPECL_OH} | 1.1 | 1.28 | 1.7 | V | DC Measurement |
| 2 | Output low voltage | V_{LVPECL_OL} | 0.4 | 0.57 | 0.9 | V | DC Measurement |
| 3 | Output differential swing** | V_{LVPECL_SW} | 0.6 | 0.71 | 0.9 | V | DC Measurement |
| 4 | Variation of V_{LVPECL_SW} for complementary output states | ΔV_{LVPECL_SW} | 0 | 0.02 | 0.05 | V | |
| 5 | Common mode output | V_{CM} | 0.8 | 0.92 | 1.2 | V | |
| 7 | Output frequency when $V_{LVPECL_SW} \geq 0.6V$ | $F_{MAX_0.6VSW}$ | | | 800 | MHz | |
| 8 | Output frequency when $V_{LVPECL_SW} \geq 0.4V$ | $F_{MAX_0.4VSW}$ | | | 1600 | MHz | |
| 9 | Rise or fall time (20% to 80%) | t_r, t_f | | 120 | 170 | ps | |
| 10 | Output frequency | F_o | 0 | | 1600 | MHz | |
| 11 | Output to output skew | t_{OOSK} | | | 40 | ps | |
| 12 | Device to device output skew | t_{DOOSK} | | | 120 | ps | |
| 13 | Input to output delay | t_{IOD} | 0.75 | 0.87 | 1.1 | ns | |
| 14 | Output enable time | t_{EN} | | | 3 | cycles | |
| 15 | Output disable time | t_{DIS} | | | 3 | cycles | |
| 16 | Additive RMS jitter in 1MHz to 20MHz band | $T_{JL_1M_20M}$ | | 65 | 91 | fs | Input clock: 100 MHz |
| | | | | 50 | 64 | fs | Input clock: 156.25MHz |
| | | | | 20 | 30 | fs | Input clock: 625 MHz |
| 17 | Additive RMS jitter in 12kHz to 20MHz band | $T_{JL_12k_20M}$ | | 69 | 99 | fs | Input clock: 100 MHz |
| | | | | 54 | 75 | fs | Input clock: 156.25MHz |
| | | | | 26 | 41 | fs | Input clock: 625 MHz |
| 18 | Noise floor | N_F | | -161 | -159 | dBc/Hz | Input clock: 100 MHz |
| | | | | -160 | -156 | dBc/Hz | Input clock: 156.25 MHz |
| | | | | -155 | -151 | dBc/Hz | Input clock: 625 MHz |

* Values are over Recommended Operating Conditions

**Output differential swing is calculated as $V_{SW} = V_{OH} - V_{OL}$. It should not be confused with $V_{SW} = 2 * (V_{OH} - V_{OL})$ used in some datasheets. Please refer to Figure 38.

Table 15 LVDS Outputs for VDDO = 3.3V*

| | Characteristics | Sym. | Min. | Typ. | Max. | Units | Notes |
|----|---|-----------------------|------|-------|------|--------|-------------------------------------|
| 1 | Output high voltage | V_{LVDS_OH} | 1.3 | 1.39 | 1.47 | V | DC Measurement |
| 2 | Output low voltage | V_{LVDS_OL} | 1.0 | 1.07 | 1.15 | V | DC Measurement |
| 3 | Output differential swing** | V_{LVDS_SW} | 0.25 | 0.32 | 0.39 | V | DC Measurement |
| 4 | Variation of V_{LVDS_SW} for complementary output states | ΔV_{LVDS_SW} | 0 | 0.002 | 0.01 | V | |
| 5 | Common mode output | V_{CM} | 1.15 | 1.23 | 1.3 | V | |
| 6 | Variation of V_{CM} for complementary output states | ΔV_{CM} | 0 | 0.001 | 0.01 | V | |
| 7 | Output frequency when $V_{LVDS_SW} \geq 250mV$ | $F_{MAX_0.25VSW}$ | | | 800 | MHz | |
| 8 | Output frequency when $V_{LVDS_SW} \geq 200mV$ | $F_{MAX_0.2VSW}$ | | | 1600 | MHz | |
| 9 | Rise or fall time (20% to 80%) | t_r, t_f | | 110 | 170 | ps | |
| 10 | Output frequency | F_O | 0 | | 1600 | MHz | |
| 11 | Output to output skew | t_{OOSK} | | | 20 | ps | |
| 12 | Device to device output skew | t_{DOOSK} | | | 130 | ps | |
| 13 | Input to output delay | t_{IOD} | 0.76 | 0.86 | 1.1 | ns | |
| 14 | Output Short Circuit Current Single Ended | I_S | -24 | | 24 | mA | Single ended outputs shorted to GND |
| 15 | Output Short Circuit Current Differential | I_{SD} | -24 | | 24 | mA | Complementary outputs shorted |
| 16 | Output enable time | t_{EN} | | | 3 | cycles | |
| 17 | Output disable time | t_{DIS} | | | 3 | cycles | |
| 18 | Additive RMS jitter in 1MHz to 20MHz band | $T_{J_1M_20M}$ | | 110 | 144 | fs | Input clock: 100 MHz |
| | | | | 63 | 81 | fs | Input clock: 156.25MHz |
| | | | | 21 | 33 | fs | Input clock: 625 MHz |
| 19 | Additive RMS jitter in 12kHz to 20MHz band | $T_{J_12k_20M}$ | | 115 | 150 | fs | Input clock: 100 MHz |
| | | | | 73 | 102 | fs | Input clock: 156.25MHz |
| | | | | 26 | 40 | fs | Input clock: 625 MHz |
| 20 | Noise floor | N_F | | -158 | -156 | dBc/Hz | Input clock: 100 MHz |
| | | | | -158 | -155 | dBc/Hz | Input clock: 156.25 MHz |
| | | | | -154 | -151 | dBc/Hz | Input clock: 625 MHz |

* Values are over Recommended Operating Conditions

**Output differential swing is calculated as $V_{SW} = V_{OH} - V_{OL}$. It should not be confused with $V_{SW} = 2 * (V_{OH} - V_{OL})$ used in some datasheets. Please refer to Figure 38.

Table 16 LVDS Outputs for VDDO = 2.5V*

| | Characteristics | Sym. | Min. | Typ. | Max. | Units | Notes |
|----|---|-----------------------|------|-------|------|--------|-------------------------------------|
| 1 | Output high voltage | V_{LVDS_OH} | 1.3 | 1.4 | 1.5 | V | DC Measurement |
| 2 | Output low voltage | V_{LVDS_OL} | 0.97 | 1.05 | 1.13 | V | DC Measurement |
| 3 | Output differential swing** | V_{LVDS_SW} | 0.25 | 0.35 | 0.44 | V | DC Measurement |
| 4 | Variation of V_{LVDS_SW} for complementary output states | ΔV_{LVDS_SW} | 0 | 0.001 | 0.01 | V | |
| 5 | Common mode output | V_{CM} | 1.15 | 1.23 | 1.3 | V | |
| 6 | Variation of V_{CM} for complementary output states | ΔV_{CM} | 0 | 0.001 | 0.01 | V | |
| 7 | Output frequency when $V_{LVDS_SW} \geq 250mV$ | $F_{MAX_0.25VSW}$ | | | 800 | MHz | |
| 8 | Output frequency when $V_{LVDS_SW} \geq 200mV$ | $F_{MAX_0.2VSW}$ | | | 1600 | MHz | |
| 9 | Rise or fall time (20% to 80%) | t_r, t_f | | 110 | 170 | ps | |
| 10 | Output frequency | F_O | 0 | | 1600 | MHz | |
| 11 | Output to output skew | t_{OOSK} | | | 20 | ps | |
| 12 | Device to device output skew | t_{DOOSK} | | | 130 | ps | |
| 13 | Input to output delay | t_{IOD} | 0.78 | 0.86 | 1.12 | ns | |
| 14 | Output Short Circuit Current Single Ended | I_S | -24 | | 24 | mA | Single ended outputs shorted to GND |
| 15 | Output Short Circuit Current Differential | I_{SD} | -24 | | 24 | mA | Complementary outputs shorted |
| 16 | Output enable time | t_{EN} | | | 3 | cycles | |
| 17 | Output disable time | t_{DIS} | | | 3 | cycles | |
| 18 | Additive RMS jitter in 1MHz to 20MHz band | $T_{J_1M_20M}$ | | 107 | 140 | fs | Input clock: 100 MHz |
| | | | | 62 | 77 | fs | Input clock: 156.25MHz |
| | | | | 20 | 31 | fs | Input clock: 625 MHz |
| 19 | Additive RMS jitter in 12kHz to 20MHz band | $T_{J_12k_20M}$ | | 111 | 146 | fs | Input clock: 100 MHz |
| | | | | 66 | 83 | fs | Input clock: 156.25MHz |
| | | | | 24 | 36 | fs | Input clock: 625 MHz |
| 20 | Noise floor | N_F | | -158 | -156 | dBc/Hz | Input clock: 100 MHz |
| | | | | -159 | -155 | dBc/Hz | Input clock: 156.25 MHz |
| | | | | -155 | -151 | dBc/Hz | Input clock: 625 MHz |

* Values are over Recommended Operating Conditions

**Output differential swing is calculated as $V_{SW} = V_{OH} - V_{OL}$. It should not be confused with $V_{SW} = 2 * (V_{OH} - V_{OL})$ used in some datasheets. Please refer to Figure 38.

Table 17 HCSL Outputs for VDDO = 3.3V*

| | Characteristics | Sym. | Min. | Typ. | Max. | Units | Notes |
|----|--|--------------------------------------|-------|-------|-------|--------|-------------------------|
| 1 | Output high voltage | $V_{\text{HCSL_OH}}$ | 0.6 | 0.85 | 1.1 | V | DC Measurement |
| 2 | Output low voltage | $V_{\text{HCSL_OL}}$ | -0.05 | 0 | 0.05 | V | DC Measurement |
| 3 | Output differential swing** | $V_{\text{HCSL_SW}}$ | 0.6 | 0.85 | 1.1 | V | DC Measurement |
| 4 | Variation of $V_{\text{HCSL_SW}}$ for complementary output states | $\Delta V_{\text{HCSL_SW}}$ | 0 | 0.003 | 0.05 | V | |
| 5 | Common mode output | V_{CM} | 0.28 | 0.43 | 0.55 | V | |
| 6 | Variation of V_{CM} for complementary output states | ΔV_{CM} | 0 | 0.002 | 0.05 | V | |
| 7 | Absolute Crossing Voltage | V_{CROSS} | 0.320 | 0.384 | 0.447 | V | |
| 8 | Total Variation of V_{CROSS} | ΔV_{CROSS} | | | 0.127 | V | |
| 9 | Output frequency | F_{MAX} | 0 | | 400 | MHz | |
| 10 | Rise or fall time (20% to 80%) | t_r, t_f | | 143 | 309 | ps | |
| 11 | Output to output skew | t_{OOSK} | | | 21 | ps | |
| 12 | Device to device output skew | t_{DOOSK} | | | 129 | ps | |
| 13 | Input to output delay | t_{IOD} | 0.73 | 0.90 | 1.08 | ns | |
| 14 | Output enable time | t_{EN} | | | 3 | cycles | |
| 15 | Output disable time | t_{DIS} | | | 3 | cycles | |
| 16 | Additive Jitter as per PCIe 3.0 (PLL_BW = 2 to 5MHz, CDR = 10MHz) | $T_{\text{JPCIe}_3.0}$ | | 20 | 40 | fs | Input clock: 100MHz |
| 17 | Additive RMS jitter in 1MHz to 20MHz band | $T_{\text{L}_1\text{M}_20\text{M}}$ | | 73 | 104 | fs | Input clock: 100 MHz |
| | | | | 53 | 69 | fs | Input clock: 156.25MHz |
| 18 | Additive RMS jitter in 12kHz to 20MHz band | $T_{\text{L}_12\text{K}_20\text{M}}$ | | 77 | 112 | fs | Input clock: 100 MHz |
| | | | | 64 | 100 | fs | Input clock: 156.25MHz |
| 19 | Noise floor | N_{F} | | -161 | -159 | dBc/Hz | Input clock: 100 MHz |
| | | | | -159 | -155 | dBc/Hz | Input clock: 156.25 MHz |

* Values are over Recommended Operating Conditions

**Output differential swing is calculated as $V_{\text{SW}} = V_{\text{OH}} - V_{\text{OL}}$. It should not be confused with $V_{\text{SW}} = 2 * (V_{\text{OH}} - V_{\text{OL}})$ used in some datasheets. Please refer to Figure 38.

Table 18 HCSL Outputs for VDDO = 2.5V*

| | Characteristics | Sym. | Min. | Typ. | Max. | Units | Notes |
|----|--|--------------------------------------|-------|-------|-------|--------|-------------------------|
| 1 | Output high voltage | $V_{\text{HCSL_OH}}$ | 0.6 | 0.83 | 1.1 | V | DC Measurement |
| 2 | Output low voltage | $V_{\text{HCSL_OL}}$ | -0.05 | 0 | 0.05 | V | DC Measurement |
| 3 | Output differential swing** | $V_{\text{HCSL_SW}}$ | 0.5 | 0.83 | 1.1 | V | DC Measurement |
| 4 | Variation of $V_{\text{HCSL_SW}}$ for complementary output states | $\Delta V_{\text{HCSL_SW}}$ | 0 | 0.003 | 0.05 | V | |
| 5 | Common mode output | V_{CM} | 0.28 | 0.42 | 0.55 | V | |
| 6 | Variation of V_{CM} for complementary output states | ΔV_{CM} | 0 | 0.002 | 0.05 | V | |
| 7 | Absolute Crossing Voltage | V_{CROSS} | 0.260 | 0.316 | 0.372 | V | |
| 8 | Total Variation of V_{CROSS} | ΔV_{CROSS} | | | 0.108 | V | |
| 9 | Output frequency | F_{MAX} | 0 | | 400 | MHz | |
| 10 | Rise or fall time (20% to 80%) | t_r, t_f | | 125 | 162 | ps | |
| 11 | Output to output skew | t_{OOSK} | | | 21 | ps | |
| 12 | Device to device output skew | t_{DOOSK} | | | 129 | ps | |
| 13 | Input to output delay | t_{IOD} | 0.76 | 0.92 | 1.10 | ns | |
| 14 | Output enable time | t_{EN} | | | 3 | cycles | |
| 15 | Output disable time | t_{DIS} | | | 3 | cycles | |
| 16 | Additive Jitter as per PCIe 3.0 (PLL_BW = 2 to 5MHz, CDR = 10MHz) | $T_{\text{JPCIe}_3.0}$ | | 20 | 40 | fs | Input clock: 100MHz |
| 17 | Additive RMS jitter in 1MHz to 20MHz band | $T_{\text{L}_1\text{M}_20\text{M}}$ | | 68 | 95 | fs | Input clock: 100 MHz |
| | | | | 52 | 66 | fs | Input clock: 156.25MHz |
| 18 | Additive RMS jitter in 12kHz to 20MHz band | $T_{\text{L}_12\text{K}_20\text{M}}$ | | 72 | 102 | fs | Input clock: 100 MHz |
| | | | | 56 | 71 | fs | Input clock: 156.25MHz |
| 19 | Noise floor | N_{F} | | -161 | -158 | dBc/Hz | Input clock: 100 MHz |
| | | | | -160 | -153 | dBc/Hz | Input clock: 156.25 MHz |

* Values are over Recommended Operating Conditions

**Output differential swing is calculated as $V_{\text{SW}} = V_{\text{OH}} - V_{\text{OL}}$. It should not be confused with $V_{\text{SW}} = 2 * (V_{\text{OH}} - V_{\text{OL}})$ used in some datasheets. Please refer to Figure 38.

Table 19 LVCMOS Output Phase Noise with 25 MHz XTAL*

| | Characteristics | Min. | Typ. | Max. | Units | Notes |
|---|----------------------------------|------|--------|--------------------------------|--------|----------------------------------|
| 1 | Jitter RMS in 12kHz to 5MHz band | | 103 | | fs | VDD = 3.3V, VDDO = 3.3V |
| | | | 117 | | fs | VDD = 2.5V; VDDO = 2.5V |
| 2 | Noise floor | | -75 | | dBc/Hz | @10Hz, VDD = 3.3V, VDDO = 3.3V |
| | | | -107 | | dBc/Hz | @100Hz, VDD = 3.3V, VDDO = 3.3V |
| | | | -132 | | dBc/Hz | @1kHz, VDD = 3.3V, VDDO = 3.3V |
| | | | -150 | | dBc/Hz | @10kHz, VDD = 3.3V, VDDO = 3.3V |
| | | | -162 | | dBc/Hz | @100kHz, VDD = 3.3V, VDDO = 3.3V |
| | | | -166 | | dBc/Hz | @1MHz, VDD = 3.3V, VDDO = 3.3V |
| | | | -166 | | dBc/Hz | @5MHz, VDD = 3.3V, VDDO = 3.3V |
| | | | -70 | | dBc/Hz | @10Hz, VDD = 2.5V; VDDO = 2.5V |
| | | | -102 | | dBc/Hz | @100Hz, VDD = 2.5V; VDDO = 2.5V |
| | | | -130 | | dBc/Hz | @1kHz, VDD = 2.5V; VDDO = 2.5V |
| | | | -149 | | dBc/Hz | @10kHz, VDD = 2.5V; VDDO = 2.5V |
| | | | -161 | | dBc/Hz | @100kHz, VDD = 2.5V; VDDO = 2.5V |
| | -165 | | dBc/Hz | @1MHz, VDD = 2.5V; VDDO = 2.5V | | |
| | -165 | | dBc/Hz | @5MHz, VDD = 2.5V; VDDO = 2.5V | | |

* Values are over Recommended Operating Conditions

Table 20 LVPECL Output Phase Noise with 25 MHz XTAL*

| | Characteristics | Min. | Typ. | Max. | Units | Notes |
|---|----------------------------------|------|--------|--------------------------------|--------|----------------------------------|
| 1 | Jitter RMS in 12kHz to 5MHz band | | 265 | | fs | VDD = 3.3V, VDDO = 3.3V |
| | | | 213 | | fs | VDD = 2.5V; VDDO = 2.5V |
| 2 | Noise floor | | -75 | | dBc/Hz | @10Hz, VDD = 3.3V, VDDO = 3.3V |
| | | | -107 | | dBc/Hz | @100Hz, VDD = 3.3V, VDDO = 3.3V |
| | | | -133 | | dBc/Hz | @1kHz, VDD = 3.3V, VDDO = 3.3V |
| | | | -152 | | dBc/Hz | @10kHz, VDD = 3.3V, VDDO = 3.3V |
| | | | -157 | | dBc/Hz | @100kHz, VDD = 3.3V, VDDO = 3.3V |
| | | | -158 | | dBc/Hz | @1MHz, VDD = 3.3V, VDDO = 3.3V |
| | | | -157 | | dBc/Hz | @5MHz, VDD = 3.3V, VDDO = 3.3V |
| | | | -71 | | dBc/Hz | @10Hz, VDD = 2.5V; VDDO = 2.5V |
| | | | -103 | | dBc/Hz | @100Hz, VDD = 2.5V; VDDO = 2.5V |
| | | | -130 | | dBc/Hz | @1kHz, VDD = 2.5V; VDDO = 2.5V |
| | | | -151 | | dBc/Hz | @10kHz, VDD = 2.5V; VDDO = 2.5V |
| | | | -158 | | dBc/Hz | @100kHz, VDD = 2.5V; VDDO = 2.5V |
| | -160 | | dBc/Hz | @1MHz, VDD = 2.5V; VDDO = 2.5V | | |
| | -159 | | dBc/Hz | @5MHz, VDD = 2.5V; VDDO = 2.5V | | |

* Values are over Recommended Operating Conditions

Table 21 LVDS Output Phase Noise with 25 MHz XTAL

| | Characteristics | Min. | Typ. | Max. | Units | Notes |
|---|----------------------------------|------|--------|--------------------------------|--------|----------------------------------|
| 1 | Jitter RMS in 12kHz to 5MHz band | | 178 | | fs | VDD = 3.3V, VDDO = 3.3V |
| | | | 190 | | fs | VDD = 2.5V; VDDO = 2.5V |
| 2 | Noise floor | | -75 | | dBc/Hz | @10Hz, VDD = 3.3V, VDDO = 3.3V |
| | | | -107 | | dBc/Hz | @100Hz, VDD = 3.3V, VDDO = 3.3V |
| | | | -133 | | dBc/Hz | @1kHz, VDD = 3.3V, VDDO = 3.3V |
| | | | -154 | | dBc/Hz | @10kHz, VDD = 3.3V, VDDO = 3.3V |
| | | | -161 | | dBc/Hz | @100kHz, VDD = 3.3V, VDDO = 3.3V |
| | | | -161 | | dBc/Hz | @1MHz, VDD = 3.3V, VDDO = 3.3V |
| | | | -160 | | dBc/Hz | @5MHz, VDD = 3.3V, VDDO = 3.3V |
| | | | -68 | | dBc/Hz | @10Hz, VDD = 2.5V; VDDO = 2.5V |
| | | | -103 | | dBc/Hz | @100Hz, VDD = 2.5V; VDDO = 2.5V |
| | | | -130 | | dBc/Hz | @1kHz, VDD = 2.5V; VDDO = 2.5V |
| | | | -152 | | dBc/Hz | @10kHz, VDD = 2.5V; VDDO = 2.5V |
| | | | -161 | | dBc/Hz | @100kHz, VDD = 2.5V; VDDO = 2.5V |
| | -160 | | dBc/Hz | @1MHz, VDD = 2.5V; VDDO = 2.5V | | |
| | -159 | | dBc/Hz | @5MHz, VDD = 2.5V; VDDO = 2.5V | | |

* Values are over Recommended Operating Conditions

Table 22 HCSL Output Phase Noise with 25 MHz XTAL

| | Characteristics | Min. | Typ. | Max. | Units | Notes |
|---|-----------------------------------|------|--------|--------------------------------|--------|----------------------------------|
| 1 | Jitter RMS in 12kHz to 20MHz band | | 269 | | fs | VDD = 3.3V, VDDO = 3.3V |
| | | | 228 | | fs | VDD = 2.5V; VDDO = 2.5V |
| 2 | Noise floor | | -76 | | dBc/Hz | @10Hz, VDD = 3.3V, VDDO = 3.3V |
| | | | -107 | | dBc/Hz | @100Hz, VDD = 3.3V, VDDO = 3.3V |
| | | | -133 | | dBc/Hz | @1kHz, VDD = 3.3V, VDDO = 3.3V |
| | | | -152 | | dBc/Hz | @10kHz, VDD = 3.3V, VDDO = 3.3V |
| | | | -157 | | dBc/Hz | @100kHz, VDD = 3.3V, VDDO = 3.3V |
| | | | -157 | | dBc/Hz | @1MHz, VDD = 3.3V, VDDO = 3.3V |
| | | | -157 | | dBc/Hz | @5MHz, VDD = 3.3V, VDDO = 3.3V |
| | | | -73 | | dBc/Hz | @10Hz, VDD = 2.5V; VDDO = 2.5V |
| | | | -105 | | dBc/Hz | @100Hz, VDD = 2.5V; VDDO = 2.5V |
| | | | -131 | | dBc/Hz | @1kHz, VDD = 2.5V; VDDO = 2.5V |
| | | | -151 | | dBc/Hz | @10kHz, VDD = 2.5V; VDDO = 2.5V |
| | | | -158 | | dBc/Hz | @100kHz, VDD = 2.5V; VDDO = 2.5V |
| | -159 | | dBc/Hz | @1MHz, VDD = 2.5V; VDDO = 2.5V | | |
| | -159 | | dBc/Hz | @5MHz, VDD = 2.5V; VDDO = 2.5V | | |

* Values are over Recommended Operating Conditions

Table 23 7x7mm QFN Package Thermal Properties

| Parameter | Symbol | Condition | Value | Units |
|--|---------------|----------------|-------|-------|
| Maximum Ambient Temperature | T_A | | 85 | °C |
| Maximum Junction Temperature | T_{JMAX} | | 125 | °C |
| Junction to Ambient Thermal Resistance ⁽¹⁾ (Note 1) | θ_{JA} | still air | 21.1 | °C/W |
| | | 1m/s airflow | 16.9 | |
| | | 2.5m/s airflow | 15.0 | |
| Junction to Board Thermal Resistance | θ_{JB} | | 6.9 | °C/W |
| Junction to Case Thermal Resistance | θ_{JC} | | 12.8 | °C/W |
| Junction to Pad Thermal Resistance ⁽²⁾ | θ_{JP} | Still air | 3.9 | °C/W |
| Junction to Top-Center Thermal Characterization Parameter | Ψ_{JT} | Still air | 0.2 | °C/W |

(1) Theta-JA (θ_{JA}) is the thermal resistance from junction to ambient when the package is mounted on an 4-layer JEDEC standard test board and dissipating maximum power

(2) Theta-JP (θ_{JP}) is the thermal resistance from junction to the center exposed pad on the bottom of the package)

Change History

June 2017 was the first release of the document.

July 2017 release changes:

- Modified power calculation in the Power Consumption section.

August 2017 release changes:

- Modified “Input driven by HCSL output” figure.
- Modified additive jitter for 156.25MHz input clock.
- Added Figure 37 and Figure 38

October 2018 release changes:

- Added note in pinout to tie XIN pin when crystal circuit is not used
- Removed Figures 15 and 16 due to inaccuracy
- Fixed typo in Table 3



Microsemi Corporate Headquarters
One Enterprise, Aliso Viejo,
CA 92656 USA

Within the USA: +1 (800) 713-4113
Outside the USA: +1 (949) 380-6100
Sales: +1 (949) 380-6136
Fax: +1 (949) 215-4996

E-mail: sales.support@microsemi.com

© 2018 Microsemi Corporation. All rights reserved. Microsemi and the Microsemi logo are trademarks of Microsemi Corporation. All other trademarks and service marks are the property of their respective owners.

Microsemi Corporation, a wholly owned subsidiary Microchip Technology Inc. (Nasdaq: MCHP), offers a comprehensive portfolio of semiconductor and system solutions for communications, defense & security, aerospace and industrial markets. Products include high-performance and radiation-hardened analog mixed-signal integrated circuits, FPGAs, SoCs and ASICs; power management products; timing and synchronization devices and precise time solutions, setting the world's standard for time; voice processing devices; RF solutions; discrete components; enterprise storage and communication solutions, security technologies and scalable anti-tamper products; Ethernet solutions; Power-over-Ethernet ICs and midspans; as well as custom design capabilities and services. Microsemi is headquartered in Aliso Viejo, California. Learn more at www.microsemi.com.

Microsemi makes no warranty, representation, or guarantee regarding the information contained herein or the suitability of its products and services for any particular purpose, nor does Microsemi assume any liability whatsoever arising out of the application or use of any product or circuit. The products sold hereunder and any other products sold by Microsemi have been subject to limited testing and should not be used in conjunction with mission-critical equipment or applications. Any performance specifications are believed to be reliable but are not verified, and Buyer must conduct and complete all performance and other testing of the products, alone and together with, or installed in, any end-products. Buyer shall not rely on any data and performance specifications or parameters provided by Microsemi. It is the Buyer's responsibility to independently determine suitability of any products and to test and verify the same. The information provided by Microsemi hereunder is provided "as is, where is" and with all faults, and the entire risk associated with such information is entirely with the Buyer. Microsemi does not grant, explicitly or implicitly, to any party any patent rights, licenses, or any other IP rights, whether with regard to such information itself or anything described by such information. Information provided in this document is proprietary to Microsemi, and Microsemi reserves the right to make any changes to the information in this document or to any products and services at any time without notice.