

bq27220

Technical Reference Manual



Literature Number: SLUUBD4
April 2016

| | |
|--|-----------|
| Preface | 7 |
| 1 General Description | 8 |
| 1.1 Gas Gauging | 8 |
| 1.1.1 CEDV Gas Gauging Operational Overview | 9 |
| 1.1.2 Main Fuel Gauge Registers | 9 |
| 1.1.3 Capacity Learning (FCC Update) and Qualified Discharge | 10 |
| 1.1.4 End-of-Discharge Thresholds and Capacity Correction | 11 |
| 1.1.5 EDV Discharge Rate and Temperature Compensation | 11 |
| 1.1.6 EDV Age Factor | 12 |
| 1.1.7 Self-Discharge | 12 |
| 1.1.8 Battery Electronic Load Compensation | 13 |
| 1.1.9 CEDV Configuration | 13 |
| 1.1.10 Initial Battery Capacity at Device Reset | 13 |
| 1.1.11 Fuel Gauge Operating Modes | 14 |
| 1.1.12 Qmax | 14 |
| 1.1.13 CEDV Smoothing | 14 |
| 2 Standard Data Commands | 16 |
| 2.1 Control()/CONTROL_STATUS(): 0x00 and 0x01 | 17 |
| 2.1.1 CONTROL_STATUS: 0x0000 | 18 |
| 2.1.2 DEVICE_NUMBER: 0x0001 | 18 |
| 2.1.3 FW_VERSION: 0x0002 | 18 |
| 2.1.4 HW_VERSION: 0x0003 | 19 |
| 2.1.5 BOARD_OFFSET: 0x0009 | 19 |
| 2.1.6 CC_OFFSET: 0x000A | 19 |
| 2.1.7 CC_OFFSET_SAVE: 0x000B | 19 |
| 2.1.8 OCV_CMD: 0x000C | 19 |
| 2.1.9 BAT_INSERT: 0x000D | 19 |
| 2.1.10 BAT_REMOVE: 0x000E | 19 |
| 2.1.11 SET_SNOOZE: 0x0013 | 19 |
| 2.1.12 CLEAR_SNOOZE: 0x0014 | 19 |
| 2.1.13 SET_PROFILE_1/2/3/4/5/6: 0x0015–0x001A | 20 |
| 2.1.14 CAL_TOGGLE: 0x002D | 20 |
| 2.1.15 SEALED: 0x0030 | 20 |
| 2.1.16 RESET: 0x0041 | 20 |
| 2.1.17 OPERATION_STATUS: 0x0054 | 20 |
| 2.1.18 GaugingStatus: 0x0056 | 20 |
| 2.1.19 EXIT_CAL: 0x0080 | 21 |
| 2.1.20 ENTER_CAL: 0x0081 | 21 |
| 2.1.21 ENTER_CFG_UPDATE: 0x0090 | 21 |
| 2.1.22 EXIT_CFG_UPDATE_REINIT: 0x0091 | 21 |
| 2.1.23 EXIT_CFG_UPDATE: 0x0092 | 21 |
| 2.1.24 ENTER_ROM: 0x0F00 | 21 |
| 2.2 AtRate(): 0x02 and 0x03 | 21 |
| 2.3 AtRateTimeToEmpty(): 0x04 and 0x05 | 21 |
| 2.4 Temperature(): 0x06 and 0x07 | 21 |

| | | |
|----------|---|-----------|
| 2.5 | Voltage(): 0x08 and 0x09 | 22 |
| 2.6 | BatteryStatus(): 0x0A and 0x0B | 22 |
| 2.7 | Current(): 0x0C and 0x0D | 23 |
| 2.8 | RemainingCapacity(): 0x10 and 0x11 | 23 |
| 2.9 | FullChargeCapacity(): 0x12 and 0x13 | 23 |
| 2.10 | TimeToEmpty(): 0x16 and 0x17 | 23 |
| 2.11 | TimeToFull(): 0x18 and 0x19 | 23 |
| 2.12 | StandbyCurrent(): 0x1A and 0x1B | 23 |
| 2.13 | StandbyTimeToEmpty(): 0x1C and 0x1D | 23 |
| 2.14 | MaxLoadCurrent(): 0x1E and 0x1F | 23 |
| 2.15 | MaxLoadTimeToEmpty(): 0x20 and 0x21 | 24 |
| 2.16 | RawCoulombCount(): 0x22 and 0x23 | 24 |
| 2.17 | AveragePower(): 0x24 and 0x25 | 24 |
| 2.18 | InternalTemperature(): 0x28 and 0x29 | 24 |
| 2.19 | CycleCount(): 0x2A and 0x2B | 24 |
| 2.20 | StateOfCharge(): 0x2C and 0x2D | 24 |
| 2.21 | StateOfHealth(): 0x2E and 0x2F | 24 |
| 2.22 | ChargingVoltage(): 0x30 and 0x31 | 24 |
| 2.23 | ChargingCurrent(): 0x32 and 0x33 | 24 |
| 2.24 | BTPDischargeSet(): 0x34 and 0x35 | 25 |
| 2.25 | BTPChargeSet(): 0x36 and 0x37 | 25 |
| 2.26 | OperationStatus(): 0x3A and 0x3B | 25 |
| 2.27 | DesignCapacity(): 0x3C and 0x3D | 25 |
| 2.28 | MACData(): 0x40 through 0x5F | 25 |
| 2.29 | MACDataSum(): 0x60 | 25 |
| 2.30 | MACDataLen(): 0x61 | 26 |
| 2.31 | AnalogCount(): 0x79 | 26 |
| 2.32 | RawCurrent(): 0x7A and 0x7B | 26 |
| 2.33 | RawVoltage(): 0x7C and 0x7D | 26 |
| 3 | Data Memory Interface | 27 |
| 3.1 | Accessing the Data Memory | 27 |
| 3.2 | Device Access Modes | 27 |
| 3.3 | Sealing and Unsealing Data Memory Access | 27 |
| 3.4 | Data Memory Summary | 28 |
| 4 | Functional Description | 44 |
| 4.1 | Device Configuration | 44 |
| 4.1.1 | CEDV Smoothing Config Register | 44 |
| 4.1.2 | Operation Configuration A (Operation Config A) Register | 44 |
| 4.1.3 | Operation Configuration B (Operation Config B) Register | 45 |
| 4.2 | External Pin Functions | 46 |
| 4.2.1 | Pin Function Code (PFC) Descriptions | 46 |
| 4.2.2 | Battery Presence Detection Using the BIN/TOUT Pin | 46 |
| 4.2.3 | SOC_INT Pin Behavior | 47 |
| 4.2.4 | Power Path Control With the BAT_GD Pin | 47 |
| 4.2.5 | Battery Trip Point (BTP) Interrupts | 47 |
| 4.2.6 | Wake-Up Comparator | 48 |
| 4.2.7 | Autocalibration | 48 |
| 4.3 | Temperature Measurement | 49 |
| 4.3.1 | Overtemperature Indication | 49 |
| 4.4 | Charging and Charge Termination Indication | 49 |
| 4.4.1 | Detecting Charge Termination | 49 |
| 4.4.2 | Charge Inhibit | 49 |
| 4.5 | Power Modes | 50 |

| | | |
|--------|--|----|
| 4.5.1 | NORMAL Mode..... | 51 |
| 4.5.2 | SLEEP Mode..... | 51 |
| 4.6 | CONFIG UPDATE Mode..... | 51 |
| 4.7 | BAT INSERT CHECK Mode..... | 51 |
| 4.8 | Application-Specific Information..... | 52 |
| 4.8.1 | Battery Profile Storage and Selection..... | 52 |
| 4.8.2 | First OCV Measurement..... | 52 |
| 4.9 | Additional Data Memory Parameter Descriptions..... | 52 |
| 4.9.1 | Calibration..... | 52 |
| 4.9.2 | Board Offset..... | 52 |
| 4.9.3 | Int Temp Offset..... | 52 |
| 4.9.4 | Ext Temp Offset..... | 53 |
| 4.9.5 | Pack VOffset..... | 53 |
| 4.9.6 | Internal Temp Model..... | 53 |
| 4.9.7 | Ext a Coef and Ext b Coef..... | 53 |
| 4.9.8 | Filter..... | 53 |
| 4.9.9 | Deadband..... | 53 |
| 4.9.10 | CC Deadband..... | 54 |
| 4.9.11 | SOC Flag Configuration A (SOC Flag Config A) Register..... | 54 |
| 4.9.12 | SOC Flag Configuration B (SOC Flag Config B) Register..... | 55 |
| 4.9.13 | CEDV Gauging Configuration (CEDV Config) Register..... | 55 |
| 4.9.14 | EMF..... | 56 |
| 4.9.15 | C0..... | 56 |
| 4.9.16 | R0..... | 56 |
| 4.9.17 | T0..... | 56 |
| 4.9.18 | R1..... | 56 |
| 4.9.19 | TC..... | 56 |
| 4.9.20 | C1..... | 56 |
| 4.9.21 | Age Factor..... | 56 |
| 4.9.22 | Fixed EDV0..... | 56 |
| 4.9.23 | Fixed EDV1..... | 57 |
| 4.9.24 | Fixed EDV2..... | 57 |
| 4.9.25 | Battery Low %..... | 57 |
| 4.9.26 | Low Temp Learning..... | 57 |
| 4.9.27 | Overload Current..... | 57 |
| 4.9.28 | Self Discharge Rate..... | 57 |
| 4.9.29 | Electronic Load..... | 57 |
| 4.9.30 | Near Full..... | 57 |
| 4.9.31 | Reserve Capacity..... | 57 |
| 4.9.32 | Charge Efficiency..... | 57 |
| 4.9.33 | Discharge Efficiency..... | 57 |
| 4.9.34 | Qmax Cell 1 and Qmax Pack..... | 57 |
| 4.9.35 | Learned Full Charge Capacity..... | 58 |
| 4.9.36 | DOD at EDV2..... | 58 |
| 4.9.37 | Cycle Count..... | 58 |
| 4.9.38 | Design Capacity..... | 58 |
| 4.9.39 | Design Voltage..... | 58 |
| 4.9.40 | Cycle Count %..... | 58 |
| 4.9.41 | Charge Inhibit Temp Low..... | 58 |
| 4.9.42 | Charge Inhibit Temp High..... | 58 |
| 4.9.43 | Temp Hys..... | 58 |
| 4.9.44 | Fast Charge Current..... | 59 |
| 4.9.45 | Charging Voltage..... | 59 |

| | | |
|----------|--|-----------|
| 4.9.46 | Taper Current | 59 |
| 4.9.47 | Taper Voltage | 59 |
| 4.9.48 | SOC Delta | 59 |
| 4.9.49 | Clock Control Register | 59 |
| 4.9.50 | Sleep Current | 59 |
| 4.9.51 | Offset Calibration Inhibit Temperature Low | 60 |
| 4.9.52 | Offset Calibration Inhibit Temperature High | 60 |
| 4.9.53 | Sleep Voltage Time | 60 |
| 4.9.54 | Sleep Current Time | 60 |
| 4.9.55 | Dsg Current Threshold | 60 |
| 4.9.56 | Chg Current Threshold | 60 |
| 4.9.57 | Quit Current | 60 |
| 4.9.58 | Dsg Relax Time | 60 |
| 4.9.59 | Chg Relax Time | 60 |
| 4.9.60 | Quit Relax Time | 60 |
| 4.9.61 | OT Charge | 60 |
| 4.9.62 | OT Chg Recovery | 61 |
| 4.9.63 | OT Discharge | 61 |
| 4.9.64 | OT Dsg Recovery | 61 |
| 4.9.65 | Initial Standby Current | 61 |
| 4.9.66 | Default Temperature | 61 |
| 4.9.67 | Device Name | 61 |
| 4.9.68 | System Down Set Voltage | 61 |
| 4.9.69 | System Down Set Voltage Time | 61 |
| 4.9.70 | System Down Clear Voltage | 61 |
| 4.9.71 | Full Reset Counter | 62 |
| 4.9.72 | Reset Counter Watchdog | 62 |
| 5 | Communications | 63 |
| 5.1 | I ² C Interface | 63 |
| 5.2 | I ² C Time Out | 63 |
| 5.3 | I ² C Command Waiting Time | 64 |
| 5.4 | I ² C Clock Stretching | 64 |
| 6 | Application Examples | 65 |
| 6.1 | Data Memory Parameter Update Example | 65 |
| A | Open-Circuit Voltage Measurement Background | 66 |
| A.1 | Background | 66 |
| A.1.1 | OCV Qualification and Calculation | 66 |
| A.1.2 | OCV Calculation Assumption | 66 |
| A.1.3 | OCV Timing | 66 |
| A.2 | OCV Timing and OCV_CMD Use Recommendations | 68 |
| A.2.1 | ACTIVE Mode (Fuel Gauge Is Not in SLEEP Mode) | 68 |
| A.2.2 | SLEEP Mode | 68 |
| A.2.3 | Initial OCV – POR | 68 |
| B | Updating bq27220 Configuration Parameters | 70 |
| B.1 | Gauge Mode FlashStream (gm.fs) Files | 70 |
| B.1.1 | Write Command | 71 |
| B.1.2 | Read and Compare Command | 72 |
| B.1.3 | Wait Command | 72 |
| B.1.4 | CONFIG UPDATE Mode | 72 |
| B.2 | OTP Mode FlashStream (ot.fs) Files | 72 |
| B.2.1 | Write Command | 73 |
| B.2.2 | Read and Compare Command | 74 |

| | | |
|----------|--|-----------|
| B.2.3 | Wait Command | 74 |
| B.2.4 | CONFIG UPDATE Mode | 74 |
| B.3 | Programming Instructions | 75 |
| B.3.1 | Using gm.fs Files | 75 |
| B.3.2 | Using ot.fs Files | 75 |
| B.4 | General Setup and Software Installation to Program OTP | 75 |
| B.5 | Launch bqStudio Software | 76 |
| B.6 | Load .GG File | 77 |
| B.7 | Confirm or Update Data Memory Parameters | 78 |
| B.8 | Save .OTFS File | 80 |
| B.9 | Launch SmartFlash Software | 81 |
| B.10 | Open Ot.fs File | 82 |
| B.11 | Program OTP | 83 |
| B.12 | Confirm Success | 84 |
| C | Glossary | 85 |
| | Revision History | 87 |

Preface

This manual discusses the modules and peripherals of the bq27220 device, and how each is used to build a complete battery pack fuel gauge solution. For further information, refer to the *bq27220 System-Side CEDV Fuel Gauge Data Sheet* ([SLUSCB7](#)).

Formatting conventions used in this document:

| Information Type | Formatting Convention | Example |
|-------------------------|--|------------------------------------|
| Commands | <i>Italics</i> with parentheses and no breaking spaces | <i>RemainingCapacity()</i> command |
| Data Memory | <i>Italics</i> , bold , and breaking spaces | Design Capacity data |
| Register bits and flags | Brackets and <i>italics</i> | [TDA] bit |
| Data Memory bits | Brackets, <i>italics</i> , and bold | [LED1] bit |
| Modes and states | ALL CAPITALS | UNSEALED mode |

Related Documentation from Texas Instruments

To obtain a copy of any of the following TI documents, go to the TI Web site at www.ti.com.

1. *bq27220 System-Side CEDV Fuel Gauge Data Sheet* ([SLUSCB7](#))
2. *Going to Production with the bq275xx Application Report* ([SLUA449](#))
3. *Host System Calibration Method Application Report* ([SLUA640](#))

Trademarks

MathCAD is a trademark of MathSoft, Inc. I²C is a trademark of NXP Semiconductors N.V. All other trademarks are the property of their respective owners.

General Description

The bq27220 fuel gauge, using Compensated End-of-Discharge Voltage (CEDV) technology, accurately predicts the battery capacity and other operational characteristics of a single series, Li-based rechargeable cell. It can be interrogated by a system processor to provide cell information such as time-to-empty (TTE), state-of-charge (SOC), and the SOC interrupt signal to the host.

Information is accessed through a series of commands, called *Standard Commands*. Further capabilities are provided by the additional *Extended Commands* set, both sets of commands, indicated by the general format *Command()*, read and write information contained within the device control and status registers, as well as its data memory locations. Commands are sent from system to gauge using the I²C™ serial communications engine, and can be executed during application development, system manufacture, or end-equipment operation.

Cell information is stored in the device in One-Time Programmable (OTP) memory. Many of these data memory locations are accessible during application development. They cannot, in general, be accessed directly during end-equipment operation. Access to these locations is achieved by either using the companion evaluation software, through individual commands, or through a sequence of data-flash-access commands. To access a desired data memory location, the correct data memory address must be known.

The fuel gauge measures charge and discharge activity by monitoring the voltage across a small-value series sense resistor (5 mΩ to 20 mΩ, typical) located between the system V_{SS} and the battery PACK-terminal. When a cell is attached to the device, information is based on cell current, cell open-circuit voltage (OCV), and cell voltage under loading conditions.

The external temperature sensing is optimized with the use of a high-accuracy negative temperature coefficient (NTC) thermistor with R₂₅ = 10.0 kΩ ±1%. B_{25/85} = 3435 kΩ ± 1% (such as Semitec NTC 103AT). Alternatively, the fuel gauge can be configured to use its internal temperature sensor or receive temperature data from the host processor. The fuel gauge uses temperature to monitor the battery-pack environment, which is used for gas gauging and cell protection functionality.

To minimize power consumption, the fuel gauge has several power modes: INITIALIZATION, NORMAL, SLEEP, and SHUTDOWN. The fuel gauge passes automatically between these modes, depending upon the occurrence of specific events, though a system processor can initiate some of these modes directly.

1.1 Gas Gauging

The bq27220 device features the Compensated End-of-Discharge Voltage (CEDV) gauging algorithm, capable of gauging a maximum capacity of 32 Ah.

[Figure 1-1](#) shows the operational overview of the bq27220 fuel gauge.

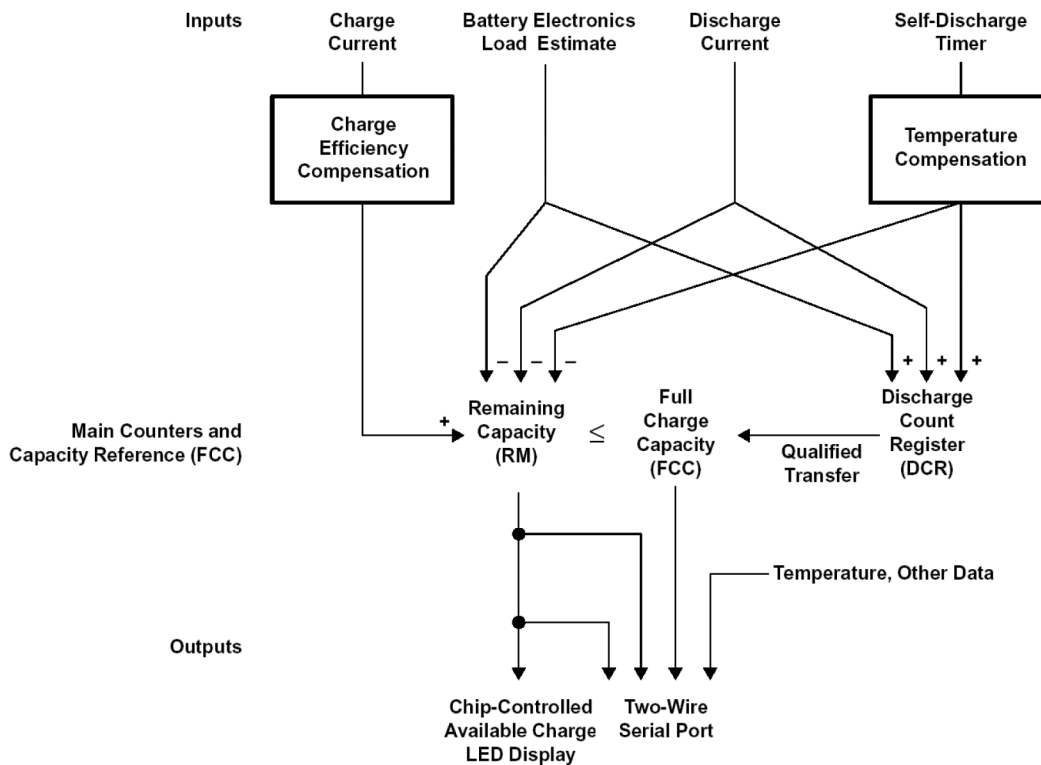

Figure 1-1. bq27220 Gas Gauging Operational Overview

1.1.1 CEDV Gas Gauging Operational Overview

The bq27220 device accumulates the measured quantities of charge and discharge and estimates self-discharge of the battery. The bq27220 device compensates the charge current measurement for temperature and state-of-charge of the battery. The bq27220 device also adjusts the self-discharge estimation based on temperature. The initial battery state-of-charge estimation on first insertion of the battery pack in the system may display a factor of the true value; the system must go through a full charge and then a full discharge cycle before the correct full-charge capacity (FCC) is estimated.

The main charge counter, *RemainingCapacity()* (RM), represents the available capacity or energy in the battery at any given time. The bq27220 device adjusts RM for charge, self-discharge, and other compensation factors. The information in the RM register is accessible through the I²C interface. The *FullChargeCapacity()* (FCC) register represents the initial or last measured full discharge of the battery. It is used as the battery full-charge reference for relative capacity indication. The bq27220 device updates FCC after the battery undergoes a qualified discharge from nearly full to a low battery level. FCC is accessible through the I²C interface.

The Discharge Count register (DCR) is an internal register that tracks discharge of the battery. The bq27220 device uses the DCR to update the FCC register if the battery undergoes a qualified discharge from nearly full to a low battery level. In this way, the bq27220 device learns the true discharge capacity of the battery under-system use conditions.

1.1.2 Main Fuel Gauge Registers

Remaining Capacity (RM) — Remaining capacity in the battery

RM represents the remaining capacity in the battery. The bq27220 device computes *RM* in units of mAh.

RM counts up during charge to a maximum value of *FCC* and down during discharge and self-discharge to a minimum of 0. In addition to charge and self-discharge compensation, the bq27220 device calibrates *RM* at three low-battery-voltage thresholds, EDV2, EDV1, and EDV0. This provides a voltage-based calibration to the *RM* counter.

Design Capacity (DC) — User-specified battery full capacity

DC is the user-specified battery full capacity. It is calculated from **Design Capacity mAh** and is represented in units of mAh. It also represents the full-battery reference for the absolute display mode.

Full Charge Capacity (FCC) — Last measured discharge capacity of the battery

FCC is the last measured discharge capacity of the battery. It is represented in units of mAh. On initialization, the bq27220 device sets *FullChargeCapacity()* to the data flash value stored in **Learned Full Charge Capacity (FCC)**. During subsequent discharges, the bq27220 device updates *FullChargeCapacity()* with the last measured discharge capacity of the battery. The last measured discharge of the battery is based on the value in the *DCR* after a qualified discharge occurs. Once updated, the bq27220 device writes the new *FullChargeCapacity()* value to data flash in mAh to **Learned Full Charge Capacity**. *FullChargeCapacity()* represents the full battery reference for the relative display mode and relative state-of-charge calculations.

Discharge Count Register (DCR) — The *DCR* counts up during discharge, independent of *RM*. The *DCR* counts discharge activity, battery load estimation, and self-discharge increment. The bq27220 device initializes the *DCR* at the beginning of a discharge to $FCC - RM$ when *RM* is within the programmed value in **Near Full**. The *DCR* initial value of $FCC - RM$ is reduced by $FCC/128$ if **[SC]** = 1 in **CEDV Gauging Configuration** and is not reduced if **[SC]** = 0. The *DCR* stops counting when the battery voltage reaches the EDV2 threshold on discharge.

1.1.3 Capacity Learning (FCC Update) and Qualified Discharge

The bq27220 device updates *FCC* with an amount based on the value in the *DCR* if a qualified discharge occurs. The new value for *FCC* equals the *DCR* value plus the programmable **Near Full** and low battery levels, per the following equation:

$$FCC \text{ (new)} = DCR \text{ (final)} = DCR \text{ (initial)} + \text{Measured Discharge to EDV2} + (FCC \times \text{Battery_Low}\%)$$

Where $\text{Battery_Low } \% = (\text{Battery Low } \% \text{ value in data flash}) \div 100$

A qualified discharge occurs if the battery discharges from $RM \geq FCC - \text{Near Full}$ to the EDV2 voltage threshold with the following conditions:

- No valid charge activity occurs during the discharge period. A valid charge is defined as a charge of 10 mAh into the battery.
- No more than 256 mAh of self-discharge or battery load estimation occurs during the discharge period.
- The temperature does not drop below the low temperature thresholds programmed in **Low Temp** during the discharge period.
- The battery voltage reaches the EDV2 threshold during the discharge period and the voltage is greater than or equal to the EDV2 threshold minus 256 mV when the bq27220 device detected EDV2.
- Current remains $\geq 3C/32$ when EDV2 is reached.
- No overload condition exists when EDV2 threshold is reached, or if *RM* has dropped to $\text{Battery_Low } \% \times FCC$.

The bq27220 device sets **[VDQ]** = 1 in *OperationStatus()* when a qualified discharge begins. The bq27220 device sets **[VDQ]** = 0 if any disqualifying condition occurs. One complication may arise regarding the state of **[VDQ]** if **[CSYNC]** is set in **CEDV Gauging Configuration**. When **[CSYNC]** is enabled, *RemainingCapacity()* is written to equal *FullChargeCapacity()* on valid primary charge termination. This capacity synchronization is done even if the condition $RM \geq FCC - \text{Near Full}$ is *not* satisfied at charge termination.

FCC cannot be reduced by more than 256 mAh or increased by more than 512 mAh during any single update cycle. If **[FCC_LIMIT]** is set in **CEDV Gauging Configuration** then *FCC* cannot learn above the **Design Capacity mAh**. The bq27220 device saves the new *FCC* value to the data flash within 4 s of being updated.

1.1.4 End-of-Discharge Thresholds and Capacity Correction

The bq27220 device monitors the battery for three low-voltage thresholds: EDV0, EDV1, and EDV2.

If the **[EDV_CMP]** bit in **CEDV Gauging Configuration** is clear, fixed EDV thresholds may be programmed in **Fixed EDV0**, **Fixed EDV1**, and **Fixed EDV2** in mV.

If the **[EDV_CMP]** bit in **CEDV Gauging Configuration** is set, automatic EDV compensation is enabled and the bq27220 device computes the EDV0, EDV1, and EDV2 thresholds based on values stored in the selected CEDV profile in data flash and the battery's current discharge rate and temperature. If the **[FIXED_EDV0]** bit in **CEDV Gauging Configuration** is also set, then the EDV0 threshold will be set to the programmed **Fixed EDV0**, and the EDV1 and EDV2 compensated thresholds will not go below the programmed **Fixed EDV0**.

The bq27220 device disables EDV detection if Current exceeds the **Overload Current** threshold. The bq27220 device resumes EDV threshold detection after Current drops below the **Overload Current** threshold. Any EDV threshold detected is reset after charge is applied and **[VDQ]** is cleared after 10 mA of charge.

The bq27220 device uses the EDV thresholds to apply voltage-based corrections to the RM register (see [Table 1-1](#)).

Table 1-1. State-of-Charge Based on Low Battery Voltage

| THRESHOLD | RELATIVE STATE OF CHARGE |
|-----------|--------------------------|
| EDV0 | 0% |
| EDV1 | 3% |
| EDV2 | Battery Low % |

The bq27220 device performs EDV-based RM adjustments with Current $\geq C/32$. No EDVs are set if Current $< C/32$. The bq27220 device adjusts RM as it detects each threshold. If the voltage threshold is reached before the corresponding capacity on discharge, the bq27220 device reduces RM to the appropriate amount as shown in [Table 1-1](#).

If an RM % level is reached on discharge before the voltage reaches the corresponding threshold, then RM is held at that % level until the threshold is reached. RM is only held if **[VDQ]** = 1, indicating a valid learning cycle is in progress. If **Battery Low %** is set to zero, EDV1 and EDV0 corrections are disabled.

1.1.5 EDV Discharge Rate and Temperature Compensation

If EDV compensation is enabled, the bq27220 device calculates battery voltage to determine EDV0, EDV1, and EDV2 thresholds as a function of battery capacity, temperature, and discharge load. The general equation for EDV0, EDV1, and EDV2 calculation is as follows:

$$EDV_{0,1,2} = n (EMF \times FBL - |I_{LOAD}| \times R_0 \times FTZ) \quad (1)$$

- EMF is a no-load cell voltage higher than the highest cell EDV threshold computed. EMF is programmed in mV in the CEDV profile **EMF**.
- I_{LOAD} is the current discharge load magnitude.
- n = the number of series cells. In the bq27220 case n = 1.
- FBL is the factor that adjusts the EDV voltage for battery capacity and temperature to match the no-load characteristics of the battery.

$$FBL = f(C_0, C + C_1, T) \quad (2)$$

- C (either 0%, 3%, or Battery Low % for EDV0, EDV1, and EDV2, respectively) and C0 are the capacity-related EDV adjustment factors. C0 is programmed in the CEDV profile **C0**. C1 is the desired residual battery capacity remaining at EDV0 (RM = 0). The C1 factor is stored in the CEDV profile **C1**.
- T is the current temperature in °K.
- $R_0 \cdot FTZ$ represents the resistance of a cell as a function of temperature and capacity.

$$FTZ = f(R_1, T_0, C + C_1, TC) \quad (3)$$

- R0 is the first order rate dependency factor stored in the CEDV profile **R0**.

- T is the current temperature; C is the battery capacity relating to EDV0, EDV1, and EDV2.
- R1 adjusts the variation of impedance with battery capacity. R1 is programmed in the CEDV profile **R1**.
- T0 adjusts the variation of impedance with battery temperature. T0 is programmed in the CEDV profile **T0**.
- TC adjusts the variation of impedance for cold temperatures ($T < 23^{\circ}\text{C}$). TC is programmed in the CEDV profile **TC**.

The graphs below show the calculated EDV0, EDV1, and EDV2 thresholds versus capacity using the typical compensation values for different temperatures and loads for a Li-Ion 18650 cell. The compensation values vary widely for different cell types and manufacturers and must be matched exactly to the unique characteristics for optimal performance.

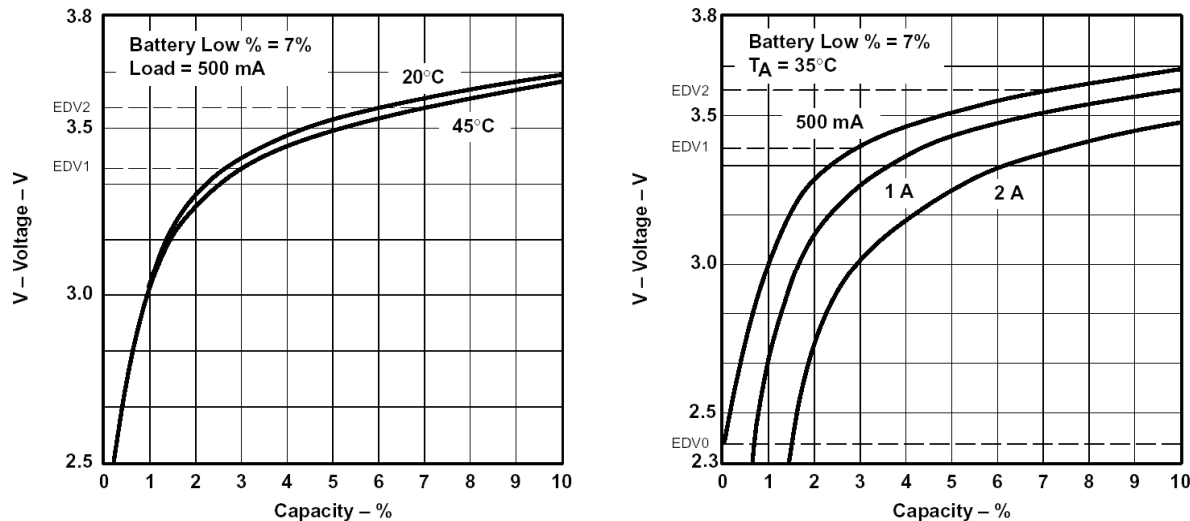

Figure 1-2. (a) EDV Calculations vs Capacity for Various Temperatures, (b) EDV Calculations vs Capacity for Various Loads

1.1.6 EDV Age Factor

The EDV **Age Factor** allows the bq27220 device to correct the EDV detection algorithm to compensate for cell aging. This parameter scales cell impedances as the cycle count increases. This new factor is used to accommodate for much higher impedances observed in larger capacity and/or aged cells. For most applications, the default value of zero is sufficient. However, for some very specific applications, this new aging factor may be required. In those cases, experimental data must be taken at the 0, 100, 200, and 300 cycle read points using a typical discharge rate while at ambient temperature. Entering this data into a TI provided MathCAD™ program will yield the appropriate EDV **Age factor** value. Contact TI Applications Support @ <http://www-k.ext.ti.com/sc/technical-support/email-tech-support.asp?AAP> for more detailed information.

1.1.7 Self-Discharge

The bq27220 device estimates the self-discharge of the battery to maintain an accurate measure of the battery capacity during periods of inactivity. The bq27220 device makes self-discharge adjustments to RM every 1/4 second when awake and periodically when in SLEEP mode. The period is determined by **Sleep Time**.

The nominal self-discharge rate, %PERDAY (% per day), is programmed in an 8-bit value **Self-Discharge Rate** by the following relation:

$$\text{Self-Discharge Rate} = \%PERDAY/0.0025$$

1.1.8 Battery Electronic Load Compensation

The bq27220 device can be configured to compensate for a constant load (as from battery electronics) present in the battery pack at all times. The bq27220 device applies the compensation continuously when the charge or discharge is below the digital filter. The bq27220 device applies the compensation in addition to self-discharge. The compensation occurs at a rate determined by the value stored in **Electronics Load**. The compensation range is 0 μA –765 μA in steps of approximately 3 μA .

The amount of internal battery electronics load estimate in μA , BEL, is stored as follows:

$$\text{Electronics Load} = \text{BEL}/3$$

1.1.9 CEDV Configuration

Various gas gauging features can be configured by the **CEDV Gauging Configuration** register.

Table 1-2. CEDV Gauging Configuration Register

| Feature | Description |
|-------------------|---|
| FCC_LIMIT | The FCC_LIMIT bit selects whether FCC limit can go above Design Capacity mAh . 0 = FCC can learn above Design Capacity mAh . 1 = FCC is limited to Design Capacity mAh . |
| SC | The SC bit enables learning cycle optimization for a Smart Charger or independent charge. 0 = Learning cycle is optimized for Smart Charger. 1 = Learning cycle is optimized for independent charger. |
| EDV_CMP | The EDV_CMP bit determines whether the bq27220 device implements automatic EDV compensation to calculate the EDV0, EDV1, and EDV2 thresholds based on rate, temperature, and capacity. If the bit is cleared, the bq27220 device uses the fixed values programmed in data flash for EDV0, EDV1, and EDV2. If the bit is set, the bq27220 device calculates EDV0, EDV1, and EDV2. 0 = EDV compensation is disabled. 1 = EDV compensation is enabled. |
| FIXED_EDV0 | The FIXED_EDV0 bit selects whether EDV0 is always fixed. 0 = EDV0 is determined based on the [EDV_CMP] bit. 1 = EDV0 will always use Fixed EDV0 . EDV1 and EDV2 compensation will not go below Fixed EDV0 . |
| CSYNC | The CSYNC bit selects whether RM is set to FCC at charge termination. 0 = RM is not changed when charge termination is reached. 1 = RM will be set to FCC when charge termination is reached. |

1.1.10 Initial Battery Capacity at Device Reset

The bq27220 device estimates the initial capacity of a battery pack at device reset, which is the case when battery cells are first attached to the application circuit. The initial **FullChargeCapacity()** (FCC) is a direct copy of the data flash parameter **Learned Full Charge Capacity**. The initial RM and RSOC are estimated using the open-circuit voltage (OCV) characteristics of the programmed Li-Ion chemistry, **DOD at EDV2**, and **Qmax Pack**. This gives a reasonably accurate RM and RSOC; however, battery capacity learning is required in order to find the accurate FCC, RM, and RSOC. During battery capacity learning, **Learned Full Charge Capacity**, and **DOD at EDV2** will be learned and updated.

The data flash **Learned Full Charge Capacity**, **DOD at EDV2**, and **Qmax Pack**, as well as the CEDV profile parameters are stored separately for each of the four selectable battery profiles. However, there is only a single OCV lookup table. The OCV table should be selected based on a best fit for all cell profiles.

The data flash parameter **Learned Full Charge Capacity** should be initialized to the **Design Capacity mAh**. **DOD at EDV2** should be initialized to $(1 - \text{Battery_Low\%}) \times 16384$, where $\text{Battery_Low\%} = \text{Battery Low \%} \div 100$.

1.1.11 Fuel Gauge Operating Modes

Entry and exit of each mode is controlled by data flash parameters in the **Current Thresholds** subclass. The *[DSG]* flag referenced below is from the MAC *GaugingStatus()* subcommand and is set in both RELAXATION and DISCHARGE modes. The *[DSG]* flag in *BatteryStatus()* is slightly different—it sets only in DISCHARGE mode and not in RELAXATION mode.

CHARGE mode is exited and RELAXATION mode is entered when *Current()* goes below **Quit Current** for a period of **Chg Relax Time**. DISCHARGE mode is entered when *Current()* goes below **(-)Dsg Current Threshold**. DISCHARGE mode is exited and RELAXATION mode is entered when *Current()* goes above **(-)Quit Current** threshold for a period of **Dsg Relax Time**. CHARGE mode is entered when *Current()* goes above **Chg Current Threshold**.

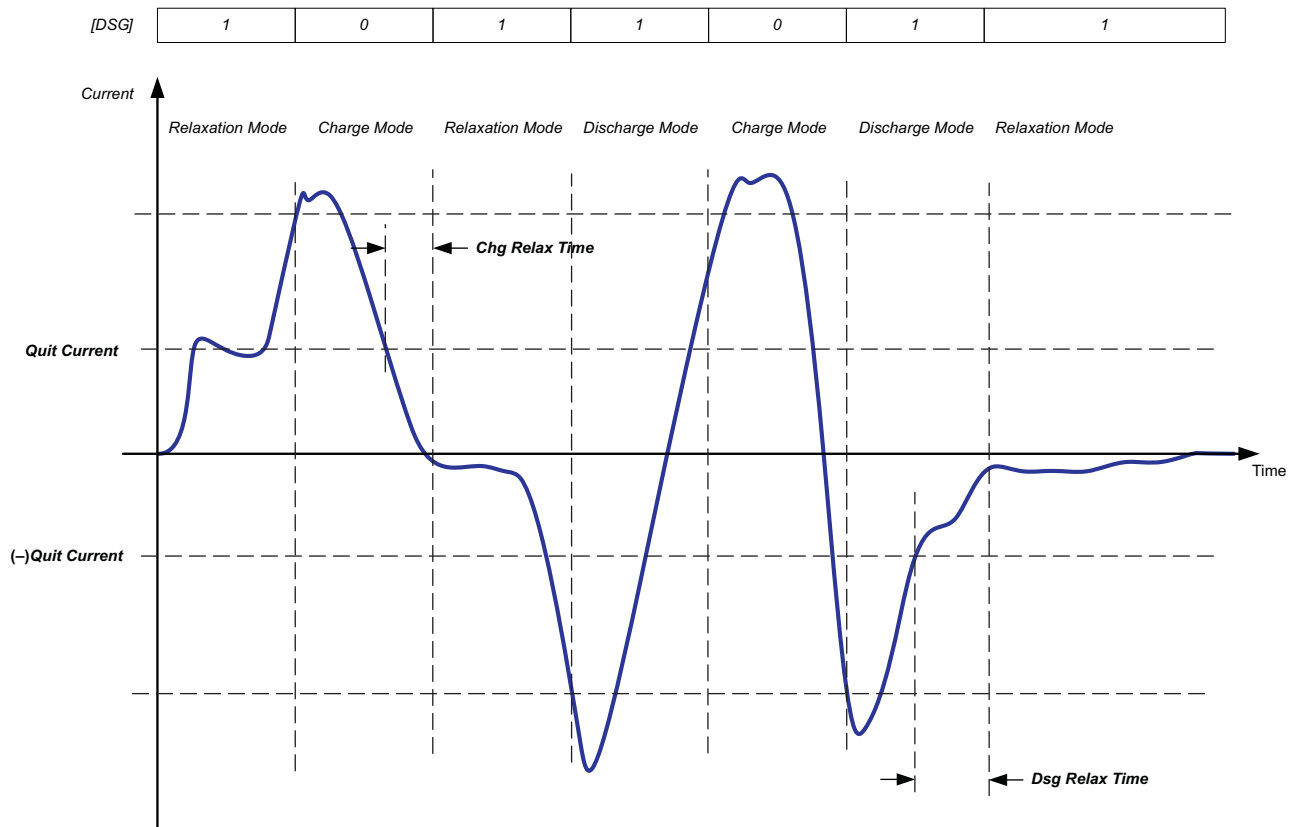

Figure 1-3. Fuel Gauge Operating Mode Example

1.1.12 Qmax

Qmax is used for initial capacity (RM and RSOC) estimates in conjunction with the cell voltages and programmed chemistry information when the device resets. The **Qmax Pack** value should be taken from the cell manufacturers' data sheet multiplied by the number of parallel cells. This is also used for the *DesignCapacity()* function and the **Design Capacity mAh** data flash value.

1.1.13 CEDV Smoothing

The bq27220 device has the ability to smooth the *RemainingCapacity()* during discharge in order to avoid a drop in *RelativeStateOfCharge()* when the EDV thresholds are reached. This feature is enabled by setting the **Smoothing Config [SMEN] = 1** and configuring the **Smoothing Start Voltage** and **Smoothing Delta Voltage**.

The smoothing will activate only when all of the following conditions are true:

- *Current()* < 0

- $Voltage() < \text{Smoothing Start Voltage}$
- EDV2 has been reached ($[EDV2] = 1$) OR $(Voltage() - \text{present EDV2 threshold}) < \text{Smoothing Delta Voltage}$.
- Maximum $Voltage()$ during the previous one minute is less than the maximum $Voltage()$ during the current minute (that is, "drop rate" is greater than 0).
- $RemainingCapacity()$ is greater than the capacity at the next EDV point.

While smoothing is active, the "drop rate" is used to estimate the time to the EDV point under the assumption that the rate is constant (linear). This information is then used to estimate how much current would need to be applied in order to have $RemainingCapacity()$ reach the expected capacity at the EDV point. The actual $Current()$ is then scaled by the "smoothing current." This will either speed up or slow down the $RemainingCapacity()$ accumulation to reach the EDV threshold at the correct time.

Whenever the $RemainingCapacity()$ accumulation is actively scaled, the $OperationStatus()[SMTH]$ bit will be set.

Smoothing deactivates whenever an EDV threshold is reached until the rate to the next EDV threshold can be calculated. However, smoothing past the EDV2 point only occurs if the **Smoothing Config [SMEXT]** is set to 1.

To improve smoothing at the end of discharge, the SME0 configuration bit provides additional flexibility. This is particularly useful when **FIXED_EDV0** is set and the calculated EDV2/EDV1 is lower than EDV0. In this scenario, the SOC smooths to EDV2, then to EDV1, and then to EDV0, leading to SOC jumps. If the SME0 bit is set, then the SOC smooths directly to EDV0, leading to a smooth transition to empty.

Table 1-3 shows the available smoothing configurations.

Table 1-3. Smoothing Configurations

| SMEN | SMEXT | SME0 | Description |
|------|-------|------|--|
| 0 | 0 | 0 | No Smoothing |
| 0 | 0 | 1 | No Smoothing |
| 0 | 1 | 0 | No Smoothing |
| 0 | 1 | 1 | No Smoothing |
| 1 | 0 | 0 | Smoothing to EDV2 |
| 1 | 0 | 1 | Smoothing to EDV0 if calculated EDV2/EDV1 is less than EDV0. |
| 1 | 1 | 0 | Smoothing to EDV2 \geq EDV1 \geq EDV0 |
| 1 | 1 | 1 | Smoothing to EDV0 if calculated EDV2/EDV1 is less than EDV0. |

The bq27220 device can also add smoothing during charging. In situations when the FCC is not updated during a discharge cycle or on a subsequent charge cycle, if the valid charge termination is reached, RSOC is synced to 100% regardless of the true RSOC. To help in scenarios like these, the device enables the SMOOTHEOC_EN bit (default is enabled).

When enabled, the RSOC value is gradually increased to 100% instead of a sudden jump if the following is true:

- Battery is charging.
- Cell Voltage > Taper Voltage
- Charge Current is decreasing AND is below the **EOC Smooth Current** threshold for **EOC Smooth Current Time**.

Standard Data Commands

The bq27220 fuel gauge uses a series of 2-byte standard commands to enable system reading and writing of battery information. Each standard command has an associated command-code pair, as indicated in [Table 2-1](#). Because each command consists of two bytes of data, two consecutive I²C transmissions must be executed both to initiate the command function and to read or write the corresponding two bytes of data. Additional options for transferring data are described in [Table 2-2](#), *Control()* commands. Read and write permissions depend on the active access mode, SEALED or UNSEALED. For details, see [Section 3.2, Device Access Modes](#). See [Chapter 5, Communications](#), for I²C details.

Table 2-1. Standard Commands

| NAME | | COMMAND CODE | UNIT | SEALED ACCESS |
|-----------------------------------|------------------|-------------------|---------|---------------|
| <i>Control()/CONTROL_STATUS()</i> | CNTL | 0x00 and 0x01 | NA | RW |
| <i>AtRate()</i> | AR | 0x02 and 0x03 | mA | RW |
| <i>AtRateTimeToEmpty()</i> | ARTTE | 0x04 and 0x05 | Minutes | R |
| <i>Temperature()</i> | TEMP | 0x06 and 0x07 | 0.1°K | RW |
| <i>Voltage()</i> | VOLT | 0x08 and 0x09 | mV | R |
| <i>BatteryStatus()</i> | <i>Flags()</i> | 0x0A and 0x0B | NA | R |
| <i>Current()</i> | <i>Current()</i> | 0x0C and 0x0D | mAh | R |
| <i>RemainingCapacity()</i> | RM | 0x10 and 0x11 | mAh | R |
| <i>FullChargeCapacity()</i> | FCC | 0x12 and 0x13 | mAh | R |
| <i>AverageCurrent()</i> | AI | 0x14 and 0x15 | mA | R |
| <i>TimeToEmpty()</i> | TTE | 0x16 and 0x17 | Minutes | R |
| <i>TimeToFull()</i> | TTF | 0x18 and 0x19 | Minutes | R |
| <i>StandbyCurrent()</i> | SI | 0x1A and 0x1B | mA | R |
| <i>StandbyTimeToEmpty()</i> | STTE | 0x1C and 0x1D | Minutes | R |
| <i>MaxLoadCurrent()</i> | MLI | 0x1E and 0x1F | mA | R |
| <i>MaxLoadTimeToEmpty()</i> | MLTTE | 0x20 and 0x21 | min | R |
| <i>RawCoulombCount()</i> | | 0x22 and 0x23 | mAh | R |
| <i>AveragePower()</i> | AP | 0x24 and 0x25 | mW | R |
| <i>InternalTemperature()</i> | INTTEMP | 0x28 and 0x29 | 0.1°K | R |
| <i>CycleCount()</i> | CC | 0x2A and 0x2B | num | R |
| <i>RelativeStateOfCharge()</i> | SOC | 0x2C and 0x2D | % | R |
| <i>StateOfHealth()</i> | SOH | 0x2E and 0x2F | %/num | R |
| <i>ChargeVoltage()</i> | CV | 0x30 and 0x31 | mV | R |
| <i>ChargeCurrent()</i> | CC | 0x32 and 0x33 | mA | R |
| <i>BTPDischargeSet()</i> | | 0x34 and 0x35 | mAh | |
| <i>BTPChargeSet()</i> | | 0x36 and 0x37 | mAh | |
| <i>OperationStatus()</i> | | 0x3A and 0x3B | NA | R |
| <i>DesignCapacity()</i> | Design Cap | 0x3C and 0x3D | mAh | R |
| <i>MACData()</i> | | 0x40 through 0x5F | | |
| <i>MACDataSum()</i> | | 0x60 | | |
| <i>MACDataLen()</i> | | 0x61 | | |

Table 2-1. Standard Commands (continued)

| NAME | COMMAND CODE | UNIT | SEALED ACCESS |
|---------------|---------------|------|---------------|
| AnalogCount() | 0x79 | | |
| RawCurrent() | 0x7A and 0x7B | | |
| RawVoltage() | 0x7C and 0x7D | | |
| RawIntTemp() | 0x7E and 0x7F | | |

2.1 Control()/CONTROL_STATUS(): 0x00 and 0x01

Issuing a *Control()* (Manufacturer Access Control or MAC) command requires a 2-byte subcommand. The subcommand specifies the particular MAC function desired. The *Control()* command allows the system to control specific features of the fuel gauge during normal operation and additional features when the device is in different access modes, as described in [Table 2-2](#). On this device, *Control()* commands may also be sent to *ManufacturerAccessControl()*. Any subcommand that has a data response will be read back on *MACData()*.

Reading the *Control()* registers will always report the *CONTROL_STATUS()* data field except after the *DEVICE_NUMBER()* and *FW_VERSION()* subcommands. After these subcommands, *CONTROL_STATUS()* will report the value 0xFFA5 one time before reverting to the normal data response. This is a flag to indicate that the data response has been moved to *MACData()*. Writing a 0x0000 to *Control()* is no longer necessary to read the *CONTROL_STATUS()*, although it is okay if it is done.

When executing commands that require data (such as data flash writes), the subcommand can be written to either *Control()* or *ManufacturerAccessControl()* registers; however, it is recommended to write using the *ManufacturerAccessControl()* registers as this allows performing the full command in a single I²C transaction.

Table 2-2. Control() MAC Subcommands

| CNTL/MAC FUNCTION | SUBCOMMAND CODE | SEALED ACCESS? | DESCRIPTION |
|-------------------|-----------------|----------------|--|
| CONTROL_STATUS | 0x0000 | Yes | Ignored by the gauge (in previous devices would enable <i>CONTROL_STATUS()</i> read) |
| DEVICE_NUMBER | 0x0001 | Yes | Reports the device type (for example: 0x0320) |
| FW_VERSION | 0x0002 | Yes | Reports the firmware version block (device, version, build, and so on) |
| BOARD_OFFSET | 0x0009 | Yes | Invokes the board offset correction |
| CC_OFFSET | 0x000A | Yes | Invokes the CC offset correction |
| CC_OFFSET_SAVE | 0x000B | Yes | Saves the results of the offset calibration process |
| OCV_CMD | 0x000C | Yes | Requests the fuel gauge to take an OCV measurement |
| BAT_INSERT | 0x000D | Yes | Forces <i>BatteryStatus()</i> [<i>BATTPRES</i>] bit set when Operation Config B [<i>BIEnable</i>] bit = 0 |
| BAT_REMOVE | 0x000E | Yes | Forces <i>BatteryStatus()</i> [<i>BATTPRES</i>] bit clear when Operation Config B [<i>BIEnable</i>] bit = 0 |
| SET_SNOOZE | 0x0013 | Yes | Forces <i>CONTROL_STATUS()</i> [<i>SNOOZE</i>] bit to 1 |
| CLEAR_SNOOZE | 0x0014 | Yes | Forces <i>CONTROL_STATUS()</i> [<i>SNOOZE</i>] bit to 0 |
| SET_PROFILE_1 | 0x0015 | Yes | Select CEDV Profile 1 |
| SET_PROFILE_2 | 0x0016 | Yes | Select CEDV Profile 2 |
| SET_PROFILE_3 | 0x0017 | Yes | Select CEDV Profile 3 |
| SET_PROFILE_4 | 0x0018 | Yes | Select CEDV Profile 4 |
| SET_PROFILE_5 | 0x0019 | Yes | Select CEDV Profile 5 |
| SET_PROFILE_6 | 0x001A | Yes | Select CEDV Profile 6 |
| CAL_TOGGLE | 0x002D | No | Toggles <i>OperationStatus()</i> [<i>CALMD</i>] |
| SEALED | 0x0030 | No | Places the fuel gauge in SEALED access mode |

Table 2-2. Control() MAC Subcommands (continued)

| CNTL/MAC FUNCTION | SUBCOMMAND CODE | SEALED ACCESS? | DESCRIPTION |
|------------------------|-----------------|----------------|--|
| RESET | 0x0041 | No | Resets device |
| EXIT_CAL | 0x0080 | No | Instructs the fuel gauge to exit CALIBRATION mode |
| ENTER_CAL | 0x0081 | No | Instructs the fuel gauge to enter CALIBRATION mode |
| ENTER_CFG_UPDATE | 0x0090 | Yes | Enter CONFIG UPDATE mode |
| EXIT_CFG_UPDATE_REINIT | 0x0091 | Yes | Exit CONFIG UPDATE mode and re-initialize |
| EXIT_CFG_UPDATE | 0x0092 | Yes | Exit CONFIG UPDATE mode without re-initialize |
| RETURN_TO_ROM | 0xF00 | No | Places the device in ROM mode |

An example using the *DEVICE_NUMBER()* subcommand:

- Write the data bytes 0x01 0x00 to the device address 0xAA starting at command 0x00.
- Then read the response using an incremental read. To the device address 0xAB, starting at command 0x3E, read four bytes. The result would be 0x01 0x00 0x20 0x03 with the first two bytes reflecting subcommand, and the second two bytes representing the device type in little endian order.

2.1.1 CONTROL_STATUS: 0x0000

A read on this command returns the 16-bit *CONTROL_STATUS()* data. The status word includes the following information:

Table 2-3. CONTROL_STATUS Bit Definitions

| | Bit 7 | Bit 6 | Bit 5 | Bit 4 | Bit 3 | Bit 2 | Bit 1 | Bit 0 |
|-----------|-------|-------|-------|-------|--------|----------|----------|----------|
| High Byte | RSVD | RSVD | RSVD | RSVD | RSVD | RSVD | RSVD | RSVD |
| Low Byte | RSVD | RSVD | CCA | BCA | SNOOZE | BATT_ID2 | BATT_ID1 | BATT_ID0 |

High Byte

RSVD = Reserved

Low Byte

RSVD = Reserved

CCA = Status bit indicating the fuel gauge Coulomb Counter Calibration routine is active. The CCA routine takes place approximately 1 minute after the initialization and periodically as gauging conditions change. Active when set. (See [Section 4.2.7, Autocalibration](#).)

BCA = Status bit indicating the fuel gauge board calibration routine is active. Active when set.

SNOOZE = Status bit indicating the SNOOZE mode is enabled. True when set.

BATT_ID2 = Battery Identification Setting2. Battery identification settings for different chemistries, used in conjunction with BATT_ID1 and BATT_ID0 (to select up to four chemistry IDs).

BATT_ID1 = Battery Identification Setting1. Battery identification settings for different chemistries, used in conjunction with BATT_ID2 and BATT_ID0 (to select up to four chemistry IDs).

BATT_ID0 = Battery Identification Setting0. Battery identification settings for different chemistries, used in conjunction with BATT_ID2 and BATT_ID1 (to select up to four chemistry IDs).

2.1.2 DEVICE_NUMBER: 0x0001

This command instructs the fuel gauge to return the device type 0x0220 to *MACData()*.

2.1.3 FW_VERSION: 0x0002

This command instructs the fuel gauge to return the firmware revision on *MACData()* in the following format:

ddDDvvVVbbBBTTzzZZRREE, where

ddDD: Device Number

vVV: Version
bbBB: Build number
ttTT: Firmware type.

2.1.4 HW_VERSION: 0x0003

This command instructs the fuel gauge to return the hardware version on subsequent read of *MACData()*.

2.1.5 BOARD_OFFSET: 0x0009

This command instructs the fuel gauge to measure and store the board offset value.

2.1.6 CC_OFFSET: 0x000A

This command instructs the fuel gauge to measure the internal CC offset value.

2.1.7 CC_OFFSET_SAVE: 0x000B

This command instructs the fuel gauge to store the internal CC offset value.

2.1.8 OCV_CMD: 0x000C

Requests the fuel gauge to take an open-circuit voltage (OCV) reading. This command can only be issued after the *OPERATION_STATUS()*[*INITCOMP*] bit is set, indicating the initialization has been completed. The OCV measurement takes place at the beginning of the next repeated 1-s firmware synchronization clock. If the **Operation Config A** [*INT_OCV*] bit is set, the SOC_INT pin pulses for approximately 512 ms if BATG_EN is 0, or 380 ms if BATG_EN is 1. (See also [Table 4-6](#).) See [Appendix A, Open-Circuit Voltage Measurement Background](#), for more details on OCV measurements and recommended usage of this command.

NOTE: The *BatteryStatus()*[*OCVFAIL*] bit is set if the *OCV_CMD()* subcommand is received when the *BatteryStatus()*[*CHGINH*] bit is set.

2.1.9 BAT_INSERT: 0x000D

This command instructs the fuel gauge to force the *BatteryStatus()* [*BATTPRES*] bit to be set and informs the gauge of the presence of a battery when the insertion detection feature is disabled (**Operation Config B** [*BIEnable*] bit = 0). Alternatively, battery presence detection can be enabled (**Operation Config B** [*BIEnable*] bit = 1) to monitor the external thermistor network. (See [Section 4.2.2, Battery Presence Detection Using the BIN Pin](#).)

2.1.10 BAT_REMOVE: 0x000E

This command instructs the fuel gauge to force the *BatteryStatus()* [*BATTPRES*] bit to clear when the battery insertion detection is disabled (**Operation Config B** [*BIEnable*] bit = 0). Alternatively, battery presence detection can be enabled (**Operation Config B** [*BIEnable*] bit = 1) to monitor the external thermistor network. (See [Section 4.2.2, Battery Presence Detection Using the BIN Pin](#).)

2.1.11 SET_SNOOZE: 0x0013

This command instructs the fuel gauge to set the *CONTROL_STATUS* [*SNOOZE*] bit to 1. This enables the SNOOZE power mode. The gauge enters the SNOOZE power mode after the transition conditions are met.

2.1.12 CLEAR_SNOOZE: 0x0014

This command instructs the fuel gauge to set the *CONTROL_STATUS* [*SNOOZE*] bit to 0. This disables the SNOOZE power mode. The gauge exits from the SNOOZE power mode after the [*SNOOZE*] bit is cleared.

2.1.13 SET_PROFILE_1/2/3/4/5/6: 0x0015–0x001A

This command instructs the device to switch the CEDV profile to one of the six pre-programmed profiles in the gauge.

2.1.14 CAL_TOGGLE: 0x002D

Toggles the *OperationStatus()*[CALMD] flag

2.1.15 SEALED: 0x0030

This instructs the fuel gauge to transition from the UNSEALED state to the SEALED state. The fuel gauge must always be set to the SEALED state for use in end-equipment.

2.1.16 RESET: 0x0041

This instructs the fuel gauge to perform a full reset. This subcommand is only available when the fuel gauge is UNSEALED.

2.1.17 OPERATION_STATUS: 0x0054

This returns the same value as the *OperationStatus()* register.

2.1.18 GaugingStatus: 0x0056

Returns the 16-bit internal gauging status register. The most often checked flags from this register are copied to the *OperationStatus()* direct read register for easier access.

Table 2-4. Gauging Status Bit Definitions

| | Bit 7 | Bit 6 | Bit 5 | Bit 4 | Bit 3 | Bit 2 | Bit 1 | Bit 0 |
|-----------|-------|-------|-------|-------|-------|-------|-------|-------|
| High Byte | VDQ | EDV2 | EDV1 | RSVD | RSVD | FCCX | RSVD | RSVD |
| Low Byte | CF | DSG | EDV | RSVD | TC | TD | FC | FD |

High Byte

RSVD = Reserved

VDQ = Indicates if current discharge cycle is NOT qualified or qualified for an FCC updated. Discharge cycle valid for FCC update is set.

EDV2 = Indicates if measured cell voltage is above or below EDV2 threshold. Below = True when set.

EDV1 = Indicates if measured cell voltage is above or below EDV1 threshold. Below = True when set.

FCCX = Control for fcc1hz clock going into CC.

0 = fcc1hz = 1 Hz
1 = fcc1hz = 16 Hz

RSVD = Reserved

Low Byte

CF = Indicates if battery conditioning is needed.

DSG = Set when in DISCHARGE or RELAXATION modes. Clear when in CHARGING mode.

EDV = Indicates if measured cell voltage is above or below EDV0 threshold. Below = True when set.

RSVD = Reserved

TC = Terminate Charge. Controlled by settings in **SOC Flag Config A**. (This flag is identical to *BatteryStatus()*[TCA].)

TD = Terminate Discharge. Controlled by settings in **SOC Flag Config A**. (This flag is identical to *BatteryStatus()*[TDA].)

FC = Full Charge. Controlled by settings in **SOC Flag Config A** and **SOC Flag Config B**. (This flag is identical to *BatteryStatus()*[FC].)

FD = Full Discharge. Controlled by settings in **SOC Flag Config B**. (This flag is identical to *BatteryStatus()*[FD].)

2.1.19 EXIT_CAL: 0x0080

This instructs the fuel gauge to exit CALIBRATION mode.

2.1.20 ENTER_CAL: 0x0081

This instructs the fuel gauge to enter CALIBRATION mode and reset *AnalogCount()* to zero if *OperationStatus()[CALMD]* is set. *[CALMD]* is controlled by the *CAL_MODE()* command.

2.1.21 ENTER_CFG_UPDATE: 0x0090

Instructs the fuel gauge to set the *Flags()* *[CFGUPMODE]* bit to 1 and enter CONFIG UPDATE mode. This command is only available when the fuel gauge is UNSEALED.

NOTE: To read the flag, the host must wait at least 2 seconds.

2.1.22 EXIT_CFG_UPDATE_REINIT: 0x0091

This command instructs the fuel gauge to exit CONFIG UPDATE mode and the gauge is re-initialized.

2.1.23 EXIT_CFG_UPDATE: 0x0092

This command instructs the fuel gauge to exit CONFIG UPDATE mode and the gauge is not re-initialized.

2.1.24 ENTER_ROM: 0x0F00

This command sends the device into ROM mode in preparation for re-programming. The *OperationStatus()[SEC1, SEC0] = 0,1 AND 0xF00* to *ManufacturerAccess()*. The device goes to ROM mode ready for updates; use 0x08 to *ManufacturerAccess()* to return.

2.2 AtRate(): 0x02 and 0x03

The *AtRate()* read- and write-word function is the first half of a two-function command set that sets the *AtRate* value used in calculations made by the *AtRateTimeToEmpty()* function. The *AtRate()* units are in mA.

The *AtRate()* value is a signed integer, with negative values interpreted as a discharge current value. The *AtRateTimeToEmpty()* function returns the predicted operating time at the *AtRate* value of discharge. The default value for *AtRate()* is 0 and forces *AtRateTimeToEmpty()* to return 65,535. Both the *AtRate()* and *AtRateTimeToEmpty()* commands must only be used in the NORMAL mode.

2.3 AtRateTimeToEmpty(): 0x04 and 0x05

This read-word function returns an unsigned integer value of the predicted remaining operating time if the battery is discharged at the *AtRate()* value in minutes with a range of 0 to 65,534. A value of 65,535 indicates *AtRate()* = 0. The fuel gauge updates *AtRateTimeToEmpty()* within 1 s after the system sets the *AtRate()* value. The fuel gauge automatically updates *AtRateTimeToEmpty()* based on the *AtRate()* value every second. Both the *AtRate()* and *AtRateTimeToEmpty()* commands must only be used in NORMAL mode.

2.4 Temperature(): 0x06 and 0x07

This read- and write-word function returns an unsigned integer value of the temperature in units of 0.1°K measured by the fuel gauge. See [Table 2-5, Temperature Measurement Options](#), and [Section 4.3, Temperature Measurement](#).

Table 2-5. Temperature Measurement Options

| Operation Config B [WRTEMP] | Operation Config A [TEMPS] | <i>Temperature()</i> Read Command | <i>Temperature()</i> Write Command |
|-----------------------------|----------------------------|--|--|
| 0 | 0 | Returns internal temperature as read from an internal sensor. This data is also available using the <i>InternalTemperature()</i> function. | The data is ignored. |
| 0 | 1 | Returns external temperature read from an external thermistor. | |
| 1 | X | Returns the <i>Temperature()</i> value previously written. | Sets the <i>Temperature()</i> to be used for gauging calculations. |

2.5 Voltage(): 0x08 and 0x09

This read-word function returns an unsigned integer value of the measured cell-pack voltage in mV with a range of 0 to 6000 mV.

2.6 BatteryStatus(): 0x0A and 0x0B

This read-word function returns the contents of the gas-gauge status register, depicting the current Battery status.

Table 2-6. Battery Status Bit Definitions

| | Bit 7 | Bit 6 | Bit 5 | Bit 4 | Bit 3 | Bit 2 | Bit 1 | Bit 0 |
|------------------|-------|---------|---------|---------|----------|-------|--------|--------|
| High Byte | FD | OCVCOMP | OCVFAIL | SLEEP | OTC | OTD | FC | CHGINH |
| Low Byte | RSVD | TCA | OCVGD | AUTH_GD | BATTPRES | TDA | SYSDWN | DSG |

High Byte

- FD = Full-discharge is detected. This flag is set and cleared based on the selected **SOC Flag Config B** options.
- OCVCOMP = An OCV measurement update is complete. True when set.
- OCVFAIL = Status bit indicating that the OCV reading failed due to current. This bit can only be set with the presence of a battery after receiving *OCV_CMD()*. True when set.
- SLEEP = Device is operating in SLEEP mode when set. This will clear temporarily during AD measurements in SLEEP mode.
- OTC = Overtemperature in charge condition is detected. If the **Operation Config B [INT_OT]** bit = 1, SOC_INT pin toggles once [OTC] bit is set.
- OTD = Overtemperature in discharge condition is detected. True when set. If the **Operation Config B [INT_OT]** bit = 1, SOC_INT pin toggles once [OTD] bit is set.
- FC = Full-charged is detected. This flag is set and cleared based on the selected **SOC Flag Config A** and **SOC Flag Config B** options.
- CHGINH = Charge inhibit: If set, indicates that charging should not begin because *Temperature()* is outside the range [Charge Inhibit Temp Low, Charge Inhibit Temp High]. True when set.

Low Byte

- TCA = Terminate Charge Alarm. This flag is set and cleared based on the selected **SOC Flag Config A** options.
- OCVGD = Good OCV measurement taken. True when set.
- AUTH_GD = Detect inserted battery. True when set.
- BATTPRES = Battery Present detected. True when set.
- TDA = Terminate Discharge Alarm. This flag is set and cleared based on the selected **SOC Flag Config A** options.
- SYSDWN = System down bit indicating the system should shut down. True when set. SOC_INT pin toggles once if set.
- DSG = The device is in DISCHARGE mode when set CHARGING or RELAXATION mode when clear.

2.7 Current(): 0x0C and 0x0D

This read-only function returns a signed integer value that is the instantaneous current flow through the sense resistor. It is updated every second. Units are mA.

2.8 RemainingCapacity(): 0x10 and 0x11

This read-only command pair returns the battery remaining capacity. When **CEDV Smoothing Config [SMEN]** is set, this will be the result of the smoothing engine. Otherwise, the unfiltered remaining capacity is returned. Units are mAh.

2.9 FullChargeCapacity(): 0x12 and 0x13

This read-only command pair returns the compensated capacity of fully charged battery Units are mAh. *FullChargeCapacity()* is updated at regular intervals, as specified by the CEDV algorithm.

2.10 TimeToEmpty(): 0x16 and 0x17

This read-only function returns an unsigned integer value of the predicted remaining battery life at the present rate of discharge, in minutes. A value of 65,535 indicates battery is not being discharged.

2.11 TimeToFull(): 0x18 and 0x19

This read-only function returns an unsigned integer value of the predicted remaining time until battery reaches full charge, in minutes, based upon *AverageCurrent()*. The computation accounts for the taper current time extension for the linear TTF computation based on a fixed *AverageCurrent()* rate of charge accumulation. A value of 65,535 indicates the battery is not being charged.

2.12 StandbyCurrent(): 0x1A and 0x1B

This read-only function returns a signed integer value of the measured standby current through the sense resistor. The *StandbyCurrent()* is an adaptive measurement. Initially, it reports the standby current programmed in **Initial Standby**, and after spending several seconds in standby, reports the measured standby current.

The register value is updated every second when the measured current is above the **Deadband** and is less than or equal to $2 \times$ **Initial Standby**. The first and last values that meet this criteria are not included, because they may not be stable values. To approximate a 1-minute time constant, each new *StandbyCurrent()* value is computed by taking approximately 93% weight of the last standby current and approximately 7% of the current measured average current.

2.13 StandbyTimeToEmpty(): 0x1C and 0x1D

This read-only function returns an unsigned integer value of the predicted remaining battery life at the standby rate of discharge in minutes. The computation uses *NominalAvailableCapacity()* (NAC), the uncompensated remaining capacity, for this computation. A value of 65,535 indicates battery is not being discharged.

2.14 MaxLoadCurrent(): 0x1E and 0x1F

This read-only function returns a signed integer value, in units of mA, of maximum load conditions. The *MaxLoadCurrent()* is an adaptive measurement, which is initially reported as the maximum load current programmed in **Initial Max Load Current**. If the measured current is ever greater than **Initial Max Load Current**, then *Max Load Current ()* is reduced to the average of the previous value and **Initial Max Load Current** whenever the battery is charged to full after a previous discharge to an SOC is less than 50%. This prevents the reported value from maintaining an unusually high value.

2.15 MaxLoadTimeToEmpty(): 0x20 and 0x21

This read-only function returns an unsigned integer value of the predicted remaining battery life at the maximum load current discharge rate in minutes. The value of 65,535 indicates that the battery is not being discharged.

2.16 RawCoulombCount(): 0x22 and 0x23

This read-only function returns an unsigned integer value of the amount of coulombs taken out of a battery during charge/discharge. The counter increments during discharge and decrements during charge. During charge, when the FC bit is set (indicating full charge), the counter is cleared to 0. The IGNORE_SD bit provides the capability to ignore a self-discharge.

IGNORE_SD = 0 (default) = Coulomb counter increments during regular or self discharge

IGNORE_SD = 1 = Coulomb counter increments only if there is a real discharge

2.17 AveragePower(): 0x24 and 0x25

This read-only function returns a signed integer value of the average power during battery charging and discharging. It is negative during discharge and positive during charge. A value of 0 indicates that the battery is not being discharged. The value is reported in units of mW.

2.18 InternalTemperature(): 0x28 and 0x29

This read-only function returns an unsigned integer value of the internal temperature sensor in units of 0.1°K measured by the fuel gauge. This function can be useful as an additional system-level temperature monitor if the main *Temperature()* function is configured for external or host-reported temperature.

2.19 CycleCount(): 0x2A and 0x2B

This read-only function returns an unsigned integer value of the number of cycles that the active cell has experienced with a range of 0 to 65535. One cycle occurs when accumulated discharge \geq cycle threshold. The cycle threshold is calculated as **Cycle Count Percentage** times either *FullChargeCapacity()* (when **CEDV Gauging Configuration [CCT]** = 1) or *DesignCapacity()* (when **[CCT]** = 0).

2.20 StateOfCharge(): 0x2C and 0x2D

This read-only function returns an unsigned integer value of the predicted remaining battery capacity expressed as a percentage of *FullChargeCapacity()*, with a range of 0 to 100%. *StateOfCharge()* = *RemainingCapacity()* \div *FullChargeCapacity()* rounded up to the nearest whole percentage point.

2.21 StateOfHealth(): 0x2E and 0x2F

This read-only function returns an unsigned integer value, expressed as a percentage of the ratio of *FullChargeCapacity()* over the *DesignCapacity()*, with a range of 0 to 100%. *StateOfHealth()* = *FullChargeCapacity()* \div *DesignCapacity()* rounded up to the nearest whole percentage point.

2.22 ChargingVoltage(): 0x30 and 0x31

This read-only function returns an unsigned integer value of the desired charging voltage of the battery. A value of 65,535 indicates that the battery is requesting the maximum voltage from the battery charger.

2.23 ChargingCurrent(): 0x32 and 0x33

This read-only function returns an unsigned integer value of the desired charging current of the battery. A value of 65,535 indicates that the battery is requesting the maximum current from the battery charger.

2.24 BTPDischargeSet(): 0x34 and 0x35

This read/write word command updates the BTP set threshold that triggers the BTP interrupt in discharge direction, and sets the *OperationStatus()*[BTPINT] bit.

2.25 BTPChargeSet(): 0x36 and 0x37

The read/write word command updates the BTP set threshold that triggers the BTP interrupt in charge direction, and sets the *OperationStatus()*[BTPINT] bit.

2.26 OperationStatus(): 0x3A and 0x3B

This read-word function returns the contents of the internal status register.

Table 2-7. Pack Status Bit Definitions

| | Bit 7 | Bit 6 | Bit 5 | Bit 4 | Bit 3 | Bit 2 | Bit 1 | Bit 0 |
|------------------|--------|-------|----------|-------|-------|-----------|-------|-------|
| High Byte | RSVD | RSVD | RSVD | RSVD | RSVD | CFGUPDATE | RSVD | RSVD |
| Low Byte | BTPINT | SMTH | INITCOMP | VDQ | EDV2 | SEC1 | SEC0 | CALMD |

High Byte

CFGUPDATE = Gauge is in CONFIG UPDATE mode. Gauging is suspended.

Low Byte

BTPINT = Flag to indicate that a BTP threshold has been crossed.

SMTH = Indicates that *RemainingCapacity()* accumulation is currently scaled by the smoothing engine.

INITCOMP = Indicates if fuel gauge initialization is complete. This bit can only be set with battery presence. True when set.

VDQ = Indicates if Current discharge cycle is NOT qualified or qualified for an FCC updated. Discharge cycle valid for FCC update is set.

EDV2 = Indicates if measured cell voltage is above or below EDV2 threshold. Below = True when set.

SEC[1:0] = Defines Current Security Access

11 = Sealed Access

10 = Unsealed Access

01 = Full Access

CALD = Toggles with 0x2D command to Enable/Disable CALIBRATION mode

2.27 DesignCapacity(): 0x3C and 0x3D

This read-only function returns the value stored in *Design Capacity mAh*. This is intended to be the theoretical or nominal capacity of a new pack, and is used for the calculation of *StateOfHealth()*.

2.28 MACData(): 0x40 through 0x5F

This read-write block will return the result data for the currently active subcommand. It is recommended to start the read at *ManufacturerAccessControl()* to verify the active subcommand.

Writes to this block are used to provide data to a subcommand when required.

2.29 MACDataSum(): 0x60

This read-write function returns the checksum of the current subcommand and data block.

Writes to this register provide the checksum necessary in order to execute subcommands that require data.

The checksum is calculated as the complement of the sum of the *ManufacturerAccessControl()* and the *MACData()* bytes. *MACDataLen()* determines the number of bytes of *MACData()* that are included in the checksum.

2.30 MACDataLen(): 0x61

This read-write function returns the number of bytes of *MACData()* that are part of the response and included in *MACDataSum()*.

Writes to this register provide the number of bytes in *MACData()* that should be processed as part of the subcommand.

Subcommands that require block data are not executed until *MACDataSum()* and *MACDataLen()* are written together as a word.

2.31 AnalogCount(): 0x79

This read-only function returns the analog counter. The value is incremented every time the analog data for calibration has been updated.

2.32 RawCurrent(): 0x7A and 0x7B

This read-only function returns the raw data from the coulomb counter.

2.33 RawVoltage(): 0x7C and 0x7D

This read-only function returns the raw data from the cell voltage reading.

Data Memory Interface

3.1 Accessing the Data Memory

The Data Memory contains initialization, default, cell status, calibration, configuration, and user information. Most Data Memory parameters reside in volatile RAM initialized by associated parameters from ROM. However, some Data Memory parameters are directly accessed from ROM and do not have an associated RAM copy. The Data Memory can be accessed in several different ways, depending in which mode the fuel gauge is operating and what data is being accessed.

Commonly accessed Data Memory locations frequently read by a system are conveniently accessed through specific instructions already described in Chapter 5, Extended Data Commands. These commands are available when the fuel gauge is either in UNSEALED or SEALED mode. Most Data Memory locations, however, are only accessible in the UNSEALED mode by use of the evaluation software or by Data Memory block transfers. These locations should be optimized and/or fixed during the development and manufacturing processes. They become part of a golden image file and then can be written to multiple battery packs. Once established, the values generally remain unchanged during end-equipment operation.

To access Data Memory locations individually, the block containing the desired Data Memory location(s) must be transferred to the command register locations, where they can be read to the system or changed directly. This is accomplished by sending the set-up command *BlockDataControl()* (0x61) with data 0x00. Up to 32 bytes of data can be read directly from the *BlockData()* (0x40 through 0x5F), externally altered, then rewritten to the *BlockData()* command space. Alternatively, specific locations can be read, altered, and rewritten if their corresponding offsets index into the *BlockData()* command space. Finally, the data residing in the command space is transferred to Data Memory, once the correct checksum for the whole block is written to *BlockDataChecksum()* (0x60). Occasionally, a Data Memory class is larger than the 32-byte block size. In this case, the *BlockData()* command designates in which 32-byte block the desired locations reside. The correct command address is then given by $0x40 + \text{offset modulo } 32$. For an example of this type of Data Memory access, see [Section 3.3](#).

Reading and writing subclass data are block operations up to 32 bytes in length. During a write, if the data length exceeds the maximum block size, then the data is ignored. None of the data written to memory is bounded by the fuel gauge—the values are not rejected by the fuel gauge. Writing an incorrect value may result in incorrect operation due to firmware program interpretation of the invalid data. The written data is not persistent, so a POR does resolve the fault.

3.2 Device Access Modes

The fuel gauge provides two access modes, UNSEALED and SEALED, that control the Data Memory access permissions. The default access mode of the fuel gauge is UNSEALED, so the system processor must send a SEALED subcommand after a gauge reset to utilize the data protection feature.

3.3 Sealing and Unsealing Data Memory Access

The fuel gauge implements a key-access scheme to transition from SEALED to UNSEALED mode. Once SEALED via the associated subcommand, a unique set of two keys must be sent to the fuel gauge via the *Control()* command to return to UNSEALED mode. The keys must be sent consecutively, with no other data being written to the *Control()* register in between. When in SEALED mode, the *OperationStatus[SEC]* bits (*SEC1, SEC0*) are set to 11; but when the Sealed to Unsealed keys are correctly received by the fuel gauge, the [*SEC*] bits (*SEC1, SEC0*) transition to 10. The Sealed to Unsealed key has two identical words stored in ROM with a value of 0x8000 8000; therefore, *Control()* should supply 0x8000 and 0x8000 (again) to unseal the part.

3.4 Data Memory Summary

Table 3-2 shows the data memory locations, including their default, minimum, and maximum values, available to customers.

Table 3-1. Data Type Decoder

| Type | Min Value | Max Value |
|------|------------------------------|-------------------------------|
| F4 | $\pm 9.8603 \times 10^{-39}$ | $\pm 5.707267 \times 10^{37}$ |
| H1 | 0x00 | 0xFF |
| H2 | 0x00 | 0xFFFF |
| H4 | 0x00 | 0xFFFF FFFF |
| I1 | -128 | 127 |
| I2 | -32768 | 32767 |
| I4 | -2,147,483,648 | 2,147,483,647 |
| Sx | 1-byte string | x-byte string |
| U1 | 0 | 255 |
| U2 | 0 | 65535 |
| U4 | 0 | 4,294,967,295 |

Table 3-2. Data Memory Table

| Class | Subclass | Address | Name | Type | Min Value | Max Value | Default | Units |
|-------------|-------------|---------|--------------------------------|------|-----------|-----------|-----------|--------|
| Calibration | Offset | 0x91B4 | Board Offset | I1 | -128 | 127 | 0 | Counts |
| Calibration | Offset | 0x91B5 | Int Temp Offset | I1 | -128 | 127 | 0 | 0.1°C |
| Calibration | Offset | 0x91B6 | Ext Temp Offset | I1 | -128 | 127 | 0 | 0.1°C |
| Calibration | Offset | 0x91B7 | Pack V Offset | I1 | -128 | 127 | 0 | mV |
| Calibration | Temperature | 0x91B8 | Internal Model Coefficient 1 | I2 | -32768 | 32767 | 0 | Num |
| Calibration | Temperature | 0x91BA | Internal Model Coefficient 2 | I2 | -32768 | 32767 | 0 | Num |
| Calibration | Temperature | 0x91BC | Internal Model Coefficient 3 | I2 | -32768 | 32767 | -13356 | Num |
| Calibration | Temperature | 0x91BE | Internal Model Coefficient 4 | I2 | -32768 | 32767 | 6661 | Num |
| Calibration | Temperature | 0x91C0 | External Model Coefficient 1 | I2 | -32768 | 32767 | -11130 | Num |
| Calibration | Temperature | 0x91C2 | External Model Coefficient 2 | I2 | -32768 | 32767 | 19142 | Num |
| Calibration | Temperature | 0x91C4 | External Model Coefficient 3 | I2 | -32768 | 32767 | -19262 | Num |
| Calibration | Temperature | 0x91C6 | External Model Coefficient 4 | I2 | -32768 | 32767 | 28203 | Num |
| Calibration | Temperature | 0x91C8 | External Model Coefficient 5 | I2 | -32768 | 32767 | 892 | Num |
| Calibration | Temperature | 0x91CA | External Model Coefficient b 1 | I2 | -32768 | 32767 | 328 | Num |
| Calibration | Temperature | 0x91CC | External Model Coefficient b 2 | I2 | -32768 | 32767 | -605 | Num |
| Calibration | Temperature | 0x91CE | External Model Coefficient b 3 | I2 | -32768 | 32767 | -2443 | Num |
| Calibration | Temperature | 0x91D0 | External Model Coefficient b 4 | I2 | -32768 | 32767 | 4696 | Num |
| Calibration | Temperature | 0x91D2 | RC0 | I2 | -32768 | 32767 | 11703 | Counts |
| Calibration | Temperature | 0x91D4 | Voltage Comp Coefficient 1 | I2 | -32768 | 32767 | 7320 | Num |
| Calibration | Temperature | 0x91D6 | Voltage Comp Coefficient 2 | I2 | -32768 | 32767 | 723 | Num |
| Calibration | Temperature | 0x91D8 | Voltage Comp Coefficient 3 | I2 | -32768 | 32767 | -71 | Num |
| Calibration | Temperature | 0x91DA | Voltage Comp Input Multiplier | U1 | 0 | 255 | 48 | Num |
| Calibration | Temperature | 0x91DB | Voltage Comp Output Divisor | I2 | -32768 | 32767 | 256 | Num |
| Calibration | Current | 0x9180 | CC Offset | I2 | -32767 | 32767 | 0 | Counts |
| Calibration | Current | 0x9182 | CC Cal Temp | I2 | 0 | 32767 | 2982 | 0.1°K |
| Calibration | Current | 0x9184 | CC Gain | F4 | 1.0e-01 | 4.0e+00 | 0.672785 | — |
| Calibration | Current | 0x9188 | CC Delta | F4 | 3.0e+04 | 3.0e+06 | 799341.14 | — |
| Calibration | Current | 0x91DD | Filter | U1 | 0 | 255 | 239 | Num |
| Calibration | Current | 0x91DE | Deadband | U1 | 0 | 255 | 5 | mA |
| Calibration | Current | 0x91DF | CC Deadband | U1 | 0 | 255 | 17 | 294 nV |

Table 3-2. Data Memory Table (continued)

| Class | Subclass | Address | Name | Type | Min Value | Max Value | Default | Units |
|---------------|---------------------|---------|-------------------------------|------|-----------|-----------|---------|-------|
| Configuration | Charge Inhibit Cfg | 0x91F5 | Chg Inhibit Temp Low | I2 | -400 | 1200 | 0 | 0.1°C |
| Configuration | Charge Inhibit Cfg | 0x91F7 | Chg Inhibit Temp High | I2 | -400 | 1200 | 450 | 0.1°C |
| Configuration | Charge Inhibit Cfg | 0x91F9 | Temp Hys | I2 | 0 | 100 | 50 | 0.1°C |
| Configuration | Charge | 0x91FB | Charging Current | I2 | 0 | 1000 | 200 | mA |
| Configuration | Charge | 0x91FD | Charging Voltage | I2 | 0 | 4600 | 4200 | mV |
| Configuration | Charge Termination | 0x9201 | Taper Current | I2 | 0 | 1000 | 100 | mA |
| Configuration | Safety | 0x9232 | OT Chg | I2 | 0 | 1200 | 550 | 0.1°C |
| Configuration | Safety | 0x9234 | OT Chg Time | U1 | 0 | 60 | 2 | s |
| Configuration | Safety | 0x9235 | OT Chg Recovery | I2 | 0 | 1200 | 500 | 0.1°C |
| Configuration | Safety | 0x9237 | OT Dsg | I2 | 0 | 1200 | 600 | 0.1°C |
| Configuration | Safety | 0x9239 | OT Dsg Time | U1 | 0 | 60 | 2 | s |
| Configuration | Safety | 0x923A | OT Dsg Recovery | I2 | 0 | 1200 | 550 | 0.1°C |
| Configuration | Registers | 0x9206 | Operation Config A | H2 | 0x0000 | 0xFFFF | 0x0484 | Hex |
| Configuration | Registers | 0x9208 | Operation Config B | H2 | 0x0000 | 0xFFFF | 0x1000 | Hex |
| Configuration | Registers | 0x920B | SOC Delta | U1 | 0 | 25 | 1 | % |
| Configuration | Registers | 0x920C | Clk Ctl Reg | H1 | 0x00 | 0x0F | 0x09 | Hex |
| Configuration | Registers | 0x9212 | Device Type | H2 | 0x0000 | 0xFFFF | 0x0220 | Hex |
| Configuration | BTP | 0x920D | IO Config | H1 | 0x0 | 0x03 | 0x00 | Hex |
| Configuration | BTP | 0x920E | Init Discharge Set | I2 | 0 | 32767 | 150 | mAh |
| Configuration | BTP | 0x9210 | Init Charge Set | I2 | 0 | 32767 | 175 | mAh |
| Configuration | Power | 0x9217 | Sleep Current | I2 | 0 | 100 | 10 | mA |
| Configuration | Power | 0x9219 | Bus Low Time | U1 | 0 | 255 | 5 | s |
| Configuration | Power | 0x921A | Offset Cal Inhibit Temp Low | I2 | -400 | 1200 | 50 | 0.1°C |
| Configuration | Power | 0x921C | Offset Cal Inhibit Temp High | I2 | -400 | 1200 | 450 | 0.1°C |
| Configuration | Power | 0x921E | Sleep Voltage Time | U1 | 0 | 100 | 20 | s |
| Configuration | Power | 0x921F | Sleep Current Time | U1 | 0 | 255 | 20 | s |
| Configuration | Current Thresholds | 0x9228 | Discharge Detection Threshold | I2 | 0 | 2000 | 60 | mA |
| Configuration | Current Thresholds | 0x922A | Charge Detection Threshold | I2 | 0 | 2000 | 75 | mA |
| Configuration | Current Thresholds | 0x922C | Quit Current | I2 | 0 | 1000 | 40 | mA |
| Configuration | Current Thresholds | 0x922E | Discharge Relax Time | U2 | 0 | 8191 | 60 | s |
| Configuration | Current Thresholds | 0x9230 | Charge Relax Time | U1 | 0 | 255 | 60 | s |
| Configuration | Current Thresholds | 0x9231 | Quit Relax Time | U1 | 0 | 63 | 1 | s |
| Configuration | Data | 0x923C | Initial Standby | I1 | -127 | 0 | -10 | mA |
| Configuration | Discharge | 0x9240 | SysDown Set Volt Threshold | I2 | 0 | 4200 | 3150 | mV |
| Configuration | Discharge | 0x9242 | SysDown Set Volt Time | U1 | 0 | 60 | 2 | s |
| Configuration | Discharge | 0x9243 | SysDown Clear Volt Threshold | I2 | 0 | 5000 | 3250 | mV |
| Configuration | SOC | 0x927F | Flag Config A | H2 | 0x0 | 0x0FFF | 0x0C8C | Hex |
| Configuration | SOC | 0x9281 | Flag Config B | H1 | 0x0 | 0xFF | 0x8C | Hex |
| Configuration | CEDV Profile Select | 0x929A | Battery ID | H1 | 0x00 | 0x1F | 0x00 | Hex |
| Gas Gauging | Cycle | 0x927D | Cycle Count Percentage | U1 | 0 | 100 | 90 | % |
| Gas Gauging | FD | 0x9282 | Set Voltage Threshold | I2 | 0 | 5000 | 3000 | mV |
| Gas Gauging | FD | 0x9284 | Clear Voltage Threshold | I2 | 0 | 5000 | 3100 | mV |
| Gas Gauging | FD | 0x9286 | Set % RSOC Threshold | U1 | 0 | 100 | 0 | % |

Table 3-2. Data Memory Table (continued)

| Class | Subclass | Address | Name | Type | Min Value | Max Value | Default | Units |
|-------------|--------------------|---------|----------------------------|------|-----------|-----------|---------|-------------|
| Gas Gauging | FD | 0x9287 | Clear % RSOC Threshold | U1 | 0 | 100 | 5 | % |
| Gas Gauging | FC | 0x9288 | Set Voltage Threshold | I2 | 0 | 5000 | 4200 | mV |
| Gas Gauging | FC | 0x928A | Clear Voltage Threshold | I2 | 0 | 5000 | 4100 | mV |
| Gas Gauging | FC | 0x928C | Set % RSOC Threshold | U1 | 0 | 100 | 100 | % |
| Gas Gauging | FC | 0x928D | Clear % RSOC Threshold | U1 | 0 | 100 | 95 | % |
| Gas Gauging | TD | 0x928E | Set Voltage Threshold | I2 | 0 | 5000 | 3200 | mV |
| Gas Gauging | TD | 0x9290 | Clear Voltage Threshold | I2 | 0 | 5000 | 3300 | mV |
| Gas Gauging | TD | 0x9292 | Set % RSOC Threshold | U1 | 0 | 100 | 6 | % |
| Gas Gauging | TD | 0x9293 | Clear % RSOC Threshold | U1 | 0 | 100 | 8 | % |
| Gas Gauging | TC | 0x9294 | Set Voltage Threshold | I2 | 0 | 5000 | 4200 | mV |
| Gas Gauging | TC | 0x9296 | Clear Voltage Threshold | I2 | 0 | 5000 | 4100 | mV |
| Gas Gauging | TC | 0x9298 | Set % RSOC Threshold | U1 | 0 | 100 | 100 | % |
| Gas Gauging | TC | 0x9299 | Clear % RSOC Threshold | U1 | 0 | 100 | 95 | % |
| Gas Gauging | CEDV Configuration | 0x9251 | Battery Low % | U2 | 0 | 65535 | 700 | .01% |
| Gas Gauging | CEDV Configuration | 0x925B | Learning Low Temp | U1 | 0 | 255 | 119 | 0.1°C |
| Gas Gauging | CEDV Configuration | 0x9264 | OverLoad Current | I2 | 0 | 32767 | 1500 | mA |
| Gas Gauging | CEDV Configuration | 0x9268 | Self Discharge Rate | U1 | 0 | 255 | 20 | 0.0025%/day |
| Gas Gauging | CEDV Configuration | 0x9269 | Electronics Load | I2 | 0 | 255 | 0 | 3 µA |
| Gas Gauging | CEDV Configuration | 0x926B | Near Full | I2 | 0 | 32767 | 200 | mAh |
| Gas Gauging | CEDV Configuration | 0x926D | Reserve Capacity | I2 | 0 | 32767 | 0 | mAh |
| Gas Gauging | CEDV Configuration | 0x926F | Chg Eff | U1 | 0 | 100 | 100 | % |
| Gas Gauging | CEDV Configuration | 0x9270 | Dsg Eff | U1 | 0 | 100 | 100 | % |
| Gas Gauging | CEDV Profile 1 | 0x929B | Gauging Configuration | H2 | 0x0 | 0x1FFF | 0x102A | Hex |
| Gas Gauging | CEDV Profile 1 | 0x929D | Full Charge Capacity | I2 | 0 | 32767 | 3000 | mAh |
| Gas Gauging | CEDV Profile 1 | 0x929F | Design Capacity | I2 | 0 | 32767 | 3000 | mAh |
| Gas Gauging | CEDV Profile 1 | 0x92A3 | Design Voltage | I2 | 0 | 32767 | 3700 | mV |
| Gas Gauging | CEDV Profile 1 | 0x92A5 | Charge Termination Voltage | I2 | 0 | 1000 | 100 | mV |
| Gas Gauging | CEDV Profile 1 | 0x92A7 | EMF | U2 | 0 | 65535 | 3743 | — |
| Gas Gauging | CEDV Profile 1 | 0x92A9 | C0 | U2 | 0 | 65535 | 149 | — |
| Gas Gauging | CEDV Profile 1 | 0x92AB | R0 | U2 | 0 | 65535 | 867 | — |
| Gas Gauging | CEDV Profile 1 | 0x92AD | T0 | U2 | 0 | 65535 | 4030 | — |
| Gas Gauging | CEDV Profile 1 | 0x92AF | R1 | U2 | 0 | 65535 | 316 | — |
| Gas Gauging | CEDV Profile 1 | 0x92B1 | TC | U1 | 0 | 255 | 9 | — |
| Gas Gauging | CEDV Profile 1 | 0x92B2 | C1 | U1 | 0 | 255 | 0 | — |
| Gas Gauging | CEDV Profile 1 | 0x92B3 | Age Factor | U1 | 0 | 255 | 0 | — |
| Gas Gauging | CEDV Profile 1 | 0x92B4 | Fixed EDV 0 | I2 | 0 | 32767 | 3031 | mV |
| Gas Gauging | CEDV Profile 1 | 0x92B6 | EDV 0 Hold Time | U1 | 1 | 255 | 1 | s |
| Gas Gauging | CEDV Profile 1 | 0x92B7 | Fixed EDV 1 | I2 | 0 | 32767 | 3385 | mV |
| Gas Gauging | CEDV Profile 1 | 0x92B9 | EDV 1 Hold Time | U1 | 1 | 255 | 1 | s |
| Gas Gauging | CEDV Profile 1 | 0x92BA | Fixed EDV 2 | I2 | 0 | 32767 | 3501 | mV |
| Gas Gauging | CEDV Profile 1 | 0x92BC | EDV 2 Hold Time | U1 | 1 | 255 | 1 | s |
| Gas Gauging | CEDV Profile 1 | 0x92BD | Voltage 0% DOD | I2 | -32768 | 32767 | 4173 | mV |
| Gas Gauging | CEDV Profile 1 | 0x92BF | Voltage 10% DOD | I2 | -32768 | 32767 | 4043 | mV |
| Gas Gauging | CEDV Profile 1 | 0x92C1 | Voltage 20% DOD | I2 | -32768 | 32767 | 3925 | mV |
| Gas Gauging | CEDV Profile 1 | 0x92C3 | Voltage 30% DOD | I2 | -32768 | 32767 | 3821 | mV |

Table 3-2. Data Memory Table (continued)

| Class | Subclass | Address | Name | Type | Min Value | Max Value | Default | Units |
|---------------------------|-----------------------|---------|--------------------------------|------|-----------|-----------|---------|--------|
| Gas Gauging | CEDV Profile 1 | 0x92C5 | Voltage 40% DOD | I2 | -32768 | 32767 | 3725 | mV |
| Gas Gauging | CEDV Profile 1 | 0x92C7 | Voltage 50% DOD | I2 | -32768 | 32767 | 3656 | mV |
| Gas Gauging | CEDV Profile 1 | 0x92C9 | Voltage 60% DOD | I2 | -32768 | 32767 | 3619 | mV |
| Gas Gauging | CEDV Profile 1 | 0x92CB | Voltage 70% DOD | I2 | -32768 | 32767 | 3582 | mV |
| Gas Gauging | CEDV Profile 1 | 0x92CD | Voltage 80% DOD | I2 | -32768 | 32767 | 3515 | mV |
| Gas Gauging | CEDV Profile 1 | 0x92CF | Voltage 90% DOD | I2 | -32768 | 32767 | 3439 | mV |
| Gas Gauging | CEDV Profile 1 | 0x92D1 | Voltage 100% DOD | I2 | -32768 | 32767 | 2713 | mV |
| Gas Gauging | CEDV Smoothing Config | 0x9271 | Smoothing Config | H1 | 0x00 | 0xFF | 0x08 | Hex |
| Gas Gauging | CEDV Smoothing Config | 0x9272 | Smoothing Start Voltage | I2 | 0 | 4300 | 3700 | mV |
| Gas Gauging | CEDV Smoothing Config | 0x9274 | Smoothing Delta Voltage | I2 | 0 | 4200 | 100 | mV |
| Gas Gauging | CEDV Smoothing Config | 0x9276 | Max Smoothing Current | I2 | 0 | 32767 | 8000 | s |
| Gas Gauging | CEDV Smoothing Config | 0x927B | EOC Smooth Current | U1 | 0 | 10 | 2 | 0.1% |
| Gas Gauging | CEDV Smoothing Config | 0x927C | EOC Smooth Current Time | U1 | 0 | 255 | 60 | s |
| Calibration (Present OTP) | Offset | 0x4000 | Board Offset | I1 | -128 | 127 | 0 | Counts |
| Calibration (Present OTP) | Offset | 0x4001 | Int Temp Offset | I1 | -128 | 127 | 0 | 0.1°C |
| Calibration (Present OTP) | Offset | 0x4002 | Ext Temp Offset | I1 | -128 | 127 | 0 | 0.1°C |
| Calibration (Present OTP) | Offset | 0x4003 | Pack V Offset | I1 | -128 | 127 | 0 | mV |
| Calibration (Present OTP) | Temperature | 0x4004 | Internal Model Coefficient 1 | I2 | -32768 | 32767 | 0 | Num |
| Calibration (Present OTP) | Temperature | 0x4006 | Internal Model Coefficient 2 | I2 | -32768 | 32767 | 0 | Num |
| Calibration (Present OTP) | Temperature | 0x4008 | Internal Model Coefficient 3 | I2 | -32768 | 32767 | -13356 | Num |
| Calibration (Present OTP) | Temperature | 0x400A | Internal Model Coefficient 4 | I2 | -32768 | 32767 | 6661 | Num |
| Calibration (Present OTP) | Temperature | 0x400C | External Model Coefficient 1 | I2 | -32768 | 32767 | -11130 | Num |
| Calibration (Present OTP) | Temperature | 0x400E | External Model Coefficient 2 | I2 | -32768 | 32767 | 19142 | Num |
| Calibration (Present OTP) | Temperature | 0x4010 | External Model Coefficient 3 | I2 | -32768 | 32767 | -19262 | Num |
| Calibration (Present OTP) | Temperature | 0x4012 | External Model Coefficient 4 | I2 | -32768 | 32767 | 28203 | Num |
| Calibration (Present OTP) | Temperature | 0x4014 | External Model Coefficient 5 | I2 | -32768 | 32767 | 892 | Num |
| Calibration (Present OTP) | Temperature | 0x4016 | External Model Coefficient b 1 | I2 | -32768 | 32767 | 328 | Num |
| Calibration (Present OTP) | Temperature | 0x4018 | External Model Coefficient b 2 | I2 | -32768 | 32767 | -605 | Num |
| Calibration (Present OTP) | Temperature | 0x401A | External Model Coefficient b 3 | I2 | -32768 | 32767 | -2443 | Num |
| Calibration (Present OTP) | Temperature | 0x401C | External Model Coefficient b 4 | I2 | -32768 | 32767 | 4696 | Num |
| Calibration (Present OTP) | Temperature | 0x401E | RC0 | I2 | -32768 | 32767 | 11703 | Counts |
| Calibration (Present OTP) | Temperature | 0x4020 | Voltage Comp Coefficient 1 | I2 | -32768 | 32767 | 7320 | Num |
| Calibration (Present OTP) | Temperature | 0x4022 | Voltage Comp Coefficient 2 | I2 | -32768 | 32767 | 723 | Num |

Table 3-2. Data Memory Table (continued)

| Class | Subclass | Address | Name | Type | Min Value | Max Value | Default | Units |
|-----------------------------|--------------------|---------|-------------------------------|------|-----------|-----------|---------|--------|
| Calibration (Present OTP) | Temperature | 0x4024 | Voltage Comp Coefficient 3 | I2 | -32768 | 32767 | -71 | Num |
| Calibration (Present OTP) | Temperature | 0x4026 | Voltage Comp Input Multiplier | U1 | 0 | 255 | 48 | Num |
| Calibration (Present OTP) | Temperature | 0x4027 | Voltage Comp Output Divisor | I2 | -32768 | 32767 | 256 | Num |
| Calibration (Present OTP) | Current | 0x4029 | Filter | U1 | 0 | 255 | 239 | Num |
| Calibration (Present OTP) | Current | 0x402A | Deadband | U1 | 0 | 255 | 5 | mA |
| Calibration (Present OTP) | Current | 0x402B | CC Deadband | U1 | 0 | 255 | 17 | 294 nV |
| Configuration (Present OTP) | Charge Inhibit Cfg | 0x4041 | Chg Inhibit Temp Low | I2 | -400 | 1200 | 0 | 0.1°C |
| Configuration (Present OTP) | Charge Inhibit Cfg | 0x4043 | Chg Inhibit Temp High | I2 | -400 | 1200 | 450 | 0.1°C |
| Configuration (Present OTP) | Charge Inhibit Cfg | 0x4045 | Temp Hys | I2 | 0 | 100 | 50 | 0.1°C |
| Configuration (Present OTP) | Charge | 0x4047 | Charging Current | I2 | 0 | 1000 | 200 | mA |
| Configuration (Present OTP) | Charge | 0x4049 | Charging Voltage | I2 | 0 | 4600 | 4200 | mV |
| Configuration (Present OTP) | Charge Termination | 0x404D | Taper Current | I2 | 0 | 1000 | 100 | mA |
| Configuration (Present OTP) | Safety | 0x407E | OT Chg | I2 | 0 | 1200 | 550 | 0.1°C |
| Configuration (Present OTP) | Safety | 0x4080 | OT Chg Time | U1 | 0 | 60 | 2 | s |
| Configuration (Present OTP) | Safety | 0x4081 | OT Chg Recovery | I2 | 0 | 1200 | 500 | 0.1°C |
| Configuration (Present OTP) | Safety | 0x4083 | OT Dsg | I2 | 0 | 1200 | 600 | 0.1°C |
| Configuration (Present OTP) | Safety | 0x4085 | OT Dsg Time | U1 | 0 | 60 | 2 | s |
| Configuration (Present OTP) | Safety | 0x4086 | OT Dsg Recovery | I2 | 0 | 1200 | 550 | 0.1°C |
| Configuration (Present OTP) | Registers | 0x4052 | Operation Config A | H2 | 0x0000 | 0xFFFF | 0x0484 | Hex |
| Configuration (Present OTP) | Registers | 0x4054 | Operation Config B | H2 | 0x0000 | 0xFFFF | 0x1000 | Hex |
| Configuration (Present OTP) | Registers | 0x4057 | SOC Delta | U1 | 0 | 25 | 1 | % |
| Configuration (Present OTP) | Registers | 0x4058 | Clk Ctl Reg | H1 | 0x00 | 0x0F | 0x09 | Hex |
| Configuration (Present OTP) | Registers | 0x405E | Device Type | H2 | 0x0000 | 0xFFFF | 0x0220 | Hex |
| Configuration (Present OTP) | BTP | 0x4059 | IO Config | H1 | 0x0 | 0x03 | 0x00 | Hex |
| Configuration (Present OTP) | BTP | 0x405A | Init Discharge Set | I2 | 0 | 32767 | 150 | mAh |
| Configuration (Present OTP) | BTP | 0x405C | Init Charge Set | I2 | 0 | 32767 | 175 | mAh |
| Configuration (Present OTP) | Power | 0x4063 | Sleep Current | I2 | 0 | 100 | 10 | mA |
| Configuration (Present OTP) | Power | 0x4065 | Bus Low Time | U1 | 0 | 255 | 5 | s |
| Configuration (Present OTP) | Power | 0x4066 | Offset Cal Inhibit Temp Low | I2 | -400 | 1200 | 50 | 0.1°C |
| Configuration (Present OTP) | Power | 0x4068 | Offset Cal Inhibit Temp High | I2 | -400 | 1200 | 450 | 0.1°C |

Table 3-2. Data Memory Table (continued)

| Class | Subclass | Address | Name | Type | Min Value | Max Value | Default | Units |
|-----------------------------|---------------------|---------|-------------------------------|------|-----------|-----------|---------|-------|
| Configuration (Present OTP) | Power | 0x406A | Sleep Voltage Time | U1 | 0 | 100 | 20 | s |
| Configuration (Present OTP) | Power | 0x406B | Sleep Current Time | U1 | 0 | 255 | 20 | s |
| Configuration (Present OTP) | Power | 0x406C | Hibernate I | U2 | 0 | 700 | 8 | mA |
| Configuration (Present OTP) | Power | 0x406E | Hibernate V | U2 | 2400 | 3000 | 2550 | mV |
| Configuration (Present OTP) | Current Thresholds | 0x4074 | Discharge Detection Threshold | I2 | 0 | 2000 | 60 | mA |
| Configuration (Present OTP) | Current Thresholds | 0x4076 | Charge Detection Threshold | I2 | 0 | 2000 | 75 | mA |
| Configuration (Present OTP) | Current Thresholds | 0x4078 | Quit Current | I2 | 0 | 1000 | 40 | mA |
| Configuration (Present OTP) | Current Thresholds | 0x407A | Discharge Relax Time | U2 | 0 | 8191 | 60 | s |
| Configuration (Present OTP) | Current Thresholds | 0x407C | Charge Relax Time | U1 | 0 | 255 | 60 | s |
| Configuration (Present OTP) | Current Thresholds | 0x407D | Quit Relax Time | U1 | 0 | 63 | 1 | s |
| Configuration (Present OTP) | Data | 0x4088 | Initial Standby | I1 | -127 | 0 | -10 | mA |
| Configuration (Present OTP) | Discharge | 0x408C | SysDown Set Volt Threshold | I2 | 0 | 4200 | 3150 | mV |
| Configuration (Present OTP) | Discharge | 0x408E | SysDown Set Volt Time | U1 | 0 | 60 | 2 | s |
| Configuration (Present OTP) | Discharge | 0x408F | SysDown Clear Volt Threshold | I2 | 0 | 5000 | 3250 | mV |
| Configuration (Present OTP) | SOC | 0x40CB | Flag Config A | H2 | 0x0 | 0x0FFF | 0x0C8C | Hex |
| Configuration (Present OTP) | SOC | 0x40CD | Flag Config B | H1 | 0x0 | 0xFF | 0x8C | Hex |
| Configuration (Present OTP) | CEDV Profile Select | 0x40E6 | Battery ID | H1 | 0x00 | 0x1F | 0x00 | Hex |
| Configuration (Present OTP) | OTP | 0x418F | Token | U1 | 0 | 255 | 0 | — |
| Gas Gauging (Present OTP) | Cycle | 0x40C9 | Cycle Count Percentage | U1 | 0 | 100 | 90 | % |
| Gas Gauging (Present OTP) | FD | 0x40CE | Set Voltage Threshold | I2 | 0 | 5000 | 3000 | mV |
| Gas Gauging (Present OTP) | FD | 0x40D0 | Clear Voltage Threshold | I2 | 0 | 5000 | 3100 | mV |
| Gas Gauging (Present OTP) | FD | 0x40D2 | Set % RSOC Threshold | U1 | 0 | 100 | 0 | % |
| Gas Gauging (Present OTP) | FD | 0x40D3 | Clear % RSOC Threshold | U1 | 0 | 100 | 5 | % |
| Gas Gauging (Present OTP) | FC | 0x40D4 | Set Voltage Threshold | I2 | 0 | 5000 | 4200 | mV |
| Gas Gauging (Present OTP) | FC | 0x40D6 | Clear Voltage Threshold | I2 | 0 | 5000 | 4100 | mV |
| Gas Gauging (Present OTP) | FC | 0x40D8 | Set % RSOC Threshold | U1 | 0 | 100 | 100 | % |
| Gas Gauging (Present OTP) | FC | 0x40D9 | Clear % RSOC Threshold | U1 | 0 | 100 | 95 | % |
| Gas Gauging (Present OTP) | TD | 0x40DA | Set Voltage Threshold | I2 | 0 | 5000 | 3200 | mV |
| Gas Gauging (Present OTP) | TD | 0x40DC | Clear Voltage Threshold | I2 | 0 | 5000 | 3300 | mV |
| Gas Gauging (Present OTP) | TD | 0x40DE | Set % RSOC Threshold | U1 | 0 | 100 | 6 | % |

Table 3-2. Data Memory Table (continued)

| Class | Subclass | Address | Name | Type | Min Value | Max Value | Default | Units |
|---------------------------|--------------------|---------|----------------------------|------|-----------|-----------|---------|--------------|
| Gas Gauging (Present OTP) | TD | 0x40DF | Clear % RSOC Threshold | U1 | 0 | 100 | 8 | % |
| Gas Gauging (Present OTP) | TC | 0x40E0 | Set Voltage Threshold | I2 | 0 | 5000 | 4200 | mV |
| Gas Gauging (Present OTP) | TC | 0x40E2 | Clear Voltage Threshold | I2 | 0 | 5000 | 4100 | mV |
| Gas Gauging (Present OTP) | TC | 0x40E4 | Set % RSOC Threshold | U1 | 0 | 100 | 100 | % |
| Gas Gauging (Present OTP) | TC | 0x40E5 | Clear % RSOC Threshold | U1 | 0 | 100 | 95 | % |
| Gas Gauging (Present OTP) | CEDV Configuration | 0x409D | Battery Low % | U2 | 0 | 65535 | 700 | .01% |
| Gas Gauging (Present OTP) | CEDV Configuration | 0x40A7 | Learning Low Temp | U1 | 0 | 255 | 119 | 0.1°C |
| Gas Gauging (Present OTP) | CEDV Configuration | 0x40B0 | OverLoad Current | I2 | 0 | 32767 | 1500 | mA |
| Gas Gauging (Present OTP) | CEDV Configuration | 0x40B4 | Self Discharge Rate | U1 | 0 | 255 | 20 | 0.0025% /day |
| Gas Gauging (Present OTP) | CEDV Configuration | 0x40B5 | Electronics Load | I2 | 0 | 255 | 0 | 3 μ A |
| Gas Gauging (Present OTP) | CEDV Configuration | 0x40B7 | Near Full | I2 | 0 | 32767 | 200 | mAh |
| Gas Gauging (Present OTP) | CEDV Configuration | 0x40B9 | Reserve Capacity | I2 | 0 | 32767 | 0 | mAh |
| Gas Gauging (Present OTP) | CEDV Configuration | 0x40BB | Chg Eff | U1 | 0 | 100 | 100 | % |
| Gas Gauging (Present OTP) | CEDV Configuration | 0x40BC | Dsg Eff | U1 | 0 | 100 | 100 | % |
| Gas Gauging (Present OTP) | CEDV Profile 1 | 0x40E7 | Gauging Configuration | H2 | 0x0 | 0x1FFF | 0x102A | Hex |
| Gas Gauging (Present OTP) | CEDV Profile 1 | 0x40E9 | Full Charge Capacity | I2 | 0 | 32767 | 3000 | mAh |
| Gas Gauging (Present OTP) | CEDV Profile 1 | 0x40EB | Design Capacity | I2 | 0 | 32767 | 3000 | mAh |
| Gas Gauging (Present OTP) | CEDV Profile 1 | 0x40EF | Design Voltage | I2 | 0 | 32767 | 3700 | mV |
| Gas Gauging (Present OTP) | CEDV Profile 1 | 0x40F1 | Charge Termination Voltage | I2 | 0 | 1000 | 100 | mV |
| Gas Gauging (Present OTP) | CEDV Profile 1 | 0x40F3 | EMF | U2 | 0 | 65535 | 3743 | — |
| Gas Gauging (Present OTP) | CEDV Profile 1 | 0x40F5 | C0 | U2 | 0 | 65535 | 149 | — |
| Gas Gauging (Present OTP) | CEDV Profile 1 | 0x40F7 | R0 | U2 | 0 | 65535 | 867 | — |
| Gas Gauging (Present OTP) | CEDV Profile 1 | 0x40F9 | T0 | U2 | 0 | 65535 | 4030 | — |
| Gas Gauging (Present OTP) | CEDV Profile 1 | 0x40FB | R1 | U2 | 0 | 65535 | 316 | — |
| Gas Gauging (Present OTP) | CEDV Profile 1 | 0x40FD | TC | U1 | 0 | 255 | 9 | — |
| Gas Gauging (Present OTP) | CEDV Profile 1 | 0x40FE | C1 | U1 | 0 | 255 | 0 | — |
| Gas Gauging (Present OTP) | CEDV Profile 1 | 0x40FF | Age Factor | U1 | 0 | 255 | 0 | — |
| Gas Gauging (Present OTP) | CEDV Profile 1 | 0x4100 | Fixed EDV 0 | I2 | 0 | 32767 | 3031 | mV |
| Gas Gauging (Present OTP) | CEDV Profile 1 | 0x4102 | EDV 0 Hold Time | U1 | 1 | 255 | 1 | s |
| Gas Gauging (Present OTP) | CEDV Profile 1 | 0x4103 | Fixed EDV 1 | I2 | 0 | 32767 | 3385 | mV |

Table 3-2. Data Memory Table (continued)

| Class | Subclass | Address | Name | Type | Min Value | Max Value | Default | Units |
|---------------------------|----------------|---------|----------------------------|------|-----------|-----------|---------|-------|
| Gas Gauging (Present OTP) | CEDV Profile 1 | 0x4105 | EDV 1 Hold Time | U1 | 1 | 255 | 1 | s |
| Gas Gauging (Present OTP) | CEDV Profile 1 | 0x4106 | Fixed EDV 2 | I2 | 0 | 32767 | 3501 | mV |
| Gas Gauging (Present OTP) | CEDV Profile 1 | 0x4108 | EDV 2 Hold Time | U1 | 1 | 255 | 1 | s |
| Gas Gauging (Present OTP) | CEDV Profile 1 | 0x4109 | Voltage 0% DOD | I2 | -32768 | 32767 | 4173 | mV |
| Gas Gauging (Present OTP) | CEDV Profile 1 | 0x410B | Voltage 10% DOD | I2 | -32768 | 32767 | 4043 | mV |
| Gas Gauging (Present OTP) | CEDV Profile 1 | 0x410D | Voltage 20% DOD | I2 | -32768 | 32767 | 3925 | mV |
| Gas Gauging (Present OTP) | CEDV Profile 1 | 0x410F | Voltage 30% DOD | I2 | -32768 | 32767 | 3821 | mV |
| Gas Gauging (Present OTP) | CEDV Profile 1 | 0x4111 | Voltage 40% DOD | I2 | -32768 | 32767 | 3725 | mV |
| Gas Gauging (Present OTP) | CEDV Profile 1 | 0x4113 | Voltage 50% DOD | I2 | -32768 | 32767 | 3656 | mV |
| Gas Gauging (Present OTP) | CEDV Profile 1 | 0x4115 | Voltage 60% DOD | I2 | -32768 | 32767 | 3619 | mV |
| Gas Gauging (Present OTP) | CEDV Profile 1 | 0x4117 | Voltage 70% DOD | I2 | -32768 | 32767 | 3582 | mV |
| Gas Gauging (Present OTP) | CEDV Profile 1 | 0x4119 | Voltage 80% DOD | I2 | -32768 | 32767 | 3515 | mV |
| Gas Gauging (Present OTP) | CEDV Profile 1 | 0x411B | Voltage 90% DOD | I2 | -32768 | 32767 | 3439 | mV |
| Gas Gauging (Present OTP) | CEDV Profile 1 | 0x411D | Voltage 100% DOD | I2 | -32768 | 32767 | 2713 | mV |
| Gas Gauging (Present OTP) | CEDV Profile 2 | 0x411F | Gauging Configuration | H2 | 0x0 | 0x1FFF | 0x0000 | Hex |
| Gas Gauging (Present OTP) | CEDV Profile 2 | 0x4121 | Full Charge Capacity | I2 | 0 | 32767 | 2200 | mAh |
| Gas Gauging (Present OTP) | CEDV Profile 2 | 0x4123 | Design Capacity | I2 | 0 | 32767 | 2200 | mAh |
| Gas Gauging (Present OTP) | CEDV Profile 2 | 0x4127 | Design Voltage | I2 | 0 | 32767 | 3700 | mV |
| Gas Gauging (Present OTP) | CEDV Profile 2 | 0x4129 | Charge Termination Voltage | I2 | 0 | 1000 | 100 | mV |
| Gas Gauging (Present OTP) | CEDV Profile 2 | 0x412B | EMF | U2 | 0 | 65535 | 3743 | — |
| Gas Gauging (Present OTP) | CEDV Profile 2 | 0x412D | C0 | U2 | 0 | 65535 | 149 | — |
| Gas Gauging (Present OTP) | CEDV Profile 2 | 0x412F | R0 | U2 | 0 | 65535 | 867 | — |
| Gas Gauging (Present OTP) | CEDV Profile 2 | 0x4131 | T0 | U2 | 0 | 65535 | 4030 | — |
| Gas Gauging (Present OTP) | CEDV Profile 2 | 0x4133 | R1 | U2 | 0 | 65535 | 316 | — |
| Gas Gauging (Present OTP) | CEDV Profile 2 | 0x4135 | TC | U1 | 0 | 255 | 9 | — |
| Gas Gauging (Present OTP) | CEDV Profile 2 | 0x4136 | C1 | U1 | 0 | 255 | 0 | — |
| Gas Gauging (Present OTP) | CEDV Profile 2 | 0x4137 | Age Factor | U1 | 0 | 255 | 0 | — |
| Gas Gauging (Present OTP) | CEDV Profile 2 | 0x4138 | Fixed EDV 0 | I2 | 0 | 32767 | 3031 | mV |
| Gas Gauging (Present OTP) | CEDV Profile 2 | 0x413A | EDV 0 Hold Time | U1 | 1 | 255 | 1 | s |
| Gas Gauging (Present OTP) | CEDV Profile 2 | 0x413B | Fixed EDV 1 | I2 | 0 | 32767 | 3385 | mV |

Table 3-2. Data Memory Table (continued)

| Class | Subclass | Address | Name | Type | Min Value | Max Value | Default | Units |
|---------------------------|----------------|---------|----------------------------|------|-----------|-----------|---------|-------|
| Gas Gauging (Present OTP) | CEDV Profile 2 | 0x413D | EDV 1 Hold Time | U1 | 1 | 255 | 1 | s |
| Gas Gauging (Present OTP) | CEDV Profile 2 | 0x413E | Fixed EDV 2 | I2 | 0 | 32767 | 3501 | mV |
| Gas Gauging (Present OTP) | CEDV Profile 2 | 0x4140 | EDV 2 Hold Time | U1 | 1 | 255 | 1 | s |
| Gas Gauging (Present OTP) | CEDV Profile 2 | 0x4141 | Voltage 0% DOD | I2 | -32768 | 32767 | 4173 | mV |
| Gas Gauging (Present OTP) | CEDV Profile 2 | 0x4143 | Voltage 10% DOD | I2 | -32768 | 32767 | 4043 | mV |
| Gas Gauging (Present OTP) | CEDV Profile 2 | 0x4145 | Voltage 20% DOD | I2 | -32768 | 32767 | 3925 | mV |
| Gas Gauging (Present OTP) | CEDV Profile 2 | 0x4147 | Voltage 30% DOD | I2 | -32768 | 32767 | 3821 | mV |
| Gas Gauging (Present OTP) | CEDV Profile 2 | 0x4149 | Voltage 40% DOD | I2 | -32768 | 32767 | 3725 | mV |
| Gas Gauging (Present OTP) | CEDV Profile 2 | 0x414B | Voltage 50% DOD | I2 | -32768 | 32767 | 3656 | mV |
| Gas Gauging (Present OTP) | CEDV Profile 2 | 0x414D | Voltage 60% DOD | I2 | -32768 | 32767 | 3619 | mV |
| Gas Gauging (Present OTP) | CEDV Profile 2 | 0x414F | Voltage 70% DOD | I2 | -32768 | 32767 | 3582 | mV |
| Gas Gauging (Present OTP) | CEDV Profile 2 | 0x4151 | Voltage 80% DOD | I2 | -32768 | 32767 | 3515 | mV |
| Gas Gauging (Present OTP) | CEDV Profile 2 | 0x4153 | Voltage 90% DOD | I2 | -32768 | 32767 | 3439 | mV |
| Gas Gauging (Present OTP) | CEDV Profile 2 | 0x4155 | Voltage 100% DOD | I2 | -32768 | 32767 | 2713 | mV |
| Gas Gauging (Present OTP) | CEDV Profile 3 | 0x4157 | Gauging Configuration | H2 | 0x0 | 0x1FFF | 0x0000 | Hex |
| Gas Gauging (Present OTP) | CEDV Profile 3 | 0x4159 | Full Charge Capacity | I2 | 0 | 32767 | 2200 | mAh |
| Gas Gauging (Present OTP) | CEDV Profile 3 | 0x415B | Design Capacity | I2 | 0 | 32767 | 2200 | mAh |
| Gas Gauging (Present OTP) | CEDV Profile 3 | 0x415F | Design Voltage | I2 | 0 | 32767 | 3700 | mV |
| Gas Gauging (Present OTP) | CEDV Profile 3 | 0x4161 | Charge Termination Voltage | I2 | 0 | 1000 | 100 | mV |
| Gas Gauging (Present OTP) | CEDV Profile 3 | 0x4163 | EMF | U2 | 0 | 65535 | 3743 | — |
| Gas Gauging (Present OTP) | CEDV Profile 3 | 0x4165 | C0 | U2 | 0 | 65535 | 149 | — |
| Gas Gauging (Present OTP) | CEDV Profile 3 | 0x4167 | R0 | U2 | 0 | 65535 | 867 | — |
| Gas Gauging (Present OTP) | CEDV Profile 3 | 0x4169 | T0 | U2 | 0 | 65535 | 4030 | — |
| Gas Gauging (Present OTP) | CEDV Profile 3 | 0x416B | R1 | U2 | 0 | 65535 | 316 | — |
| Gas Gauging (Present OTP) | CEDV Profile 3 | 0x416D | TC | U1 | 0 | 255 | 9 | — |
| Gas Gauging (Present OTP) | CEDV Profile 3 | 0x416E | C1 | U1 | 0 | 255 | 0 | — |
| Gas Gauging (Present OTP) | CEDV Profile 3 | 0x416F | Age Factor | U1 | 0 | 255 | 0 | — |
| Gas Gauging (Present OTP) | CEDV Profile 3 | 0x4170 | Fixed EDV 0 | I2 | 0 | 32767 | 3031 | mV |
| Gas Gauging (Present OTP) | CEDV Profile 3 | 0x4172 | EDV 0 Hold Time | U1 | 1 | 255 | 1 | s |
| Gas Gauging (Present OTP) | CEDV Profile 3 | 0x4173 | Fixed EDV 1 | I2 | 0 | 32767 | 3385 | mV |

Table 3-2. Data Memory Table (continued)

| Class | Subclass | Address | Name | Type | Min Value | Max Value | Default | Units |
|---------------------------|-----------------------|---------|------------------------------|------|-----------|-----------|---------|--------|
| Gas Gauging (Present OTP) | CEDV Profile 3 | 0x4175 | EDV 1 Hold Time | U1 | 1 | 255 | 1 | s |
| Gas Gauging (Present OTP) | CEDV Profile 3 | 0x4176 | Fixed EDV 2 | I2 | 0 | 32767 | 3501 | mV |
| Gas Gauging (Present OTP) | CEDV Profile 3 | 0x4178 | EDV 2 Hold Time | U1 | 1 | 255 | 1 | s |
| Gas Gauging (Present OTP) | CEDV Profile 3 | 0x4179 | Voltage 0% DOD | I2 | -32768 | 32767 | 4173 | mV |
| Gas Gauging (Present OTP) | CEDV Profile 3 | 0x417B | Voltage 10% DOD | I2 | -32768 | 32767 | 4043 | mV |
| Gas Gauging (Present OTP) | CEDV Profile 3 | 0x417D | Voltage 20% DOD | I2 | -32768 | 32767 | 3925 | mV |
| Gas Gauging (Present OTP) | CEDV Profile 3 | 0x417F | Voltage 30% DOD | I2 | -32768 | 32767 | 3821 | mV |
| Gas Gauging (Present OTP) | CEDV Profile 3 | 0x4181 | Voltage 40% DOD | I2 | -32768 | 32767 | 3725 | mV |
| Gas Gauging (Present OTP) | CEDV Profile 3 | 0x4183 | Voltage 50% DOD | I2 | -32768 | 32767 | 3656 | mV |
| Gas Gauging (Present OTP) | CEDV Profile 3 | 0x4185 | Voltage 60% DOD | I2 | -32768 | 32767 | 3619 | mV |
| Gas Gauging (Present OTP) | CEDV Profile 3 | 0x4187 | Voltage 70% DOD | I2 | -32768 | 32767 | 3582 | mV |
| Gas Gauging (Present OTP) | CEDV Profile 3 | 0x4189 | Voltage 80% DOD | I2 | -32768 | 32767 | 3515 | mV |
| Gas Gauging (Present OTP) | CEDV Profile 3 | 0x418B | Voltage 90% DOD | I2 | -32768 | 32767 | 3439 | mV |
| Gas Gauging (Present OTP) | CEDV Profile 3 | 0x418D | Voltage 100% DOD | I2 | -32768 | 32767 | 2713 | mV |
| Gas Gauging (Present OTP) | CEDV Smoothing Config | 0x40BD | Smoothing Config | H1 | 0x00 | 0xFF | 0x08 | Hex |
| Gas Gauging (Present OTP) | CEDV Smoothing Config | 0x40BE | Smoothing Start Voltage | I2 | 0 | 4300 | 3700 | mV |
| Gas Gauging (Present OTP) | CEDV Smoothing Config | 0x40C0 | Smoothing Delta Voltage | I2 | 0 | 4200 | 100 | mV |
| Gas Gauging (Present OTP) | CEDV Smoothing Config | 0x40C2 | Max Smoothing Current | I2 | 0 | 32767 | 8000 | s |
| Gas Gauging (Present OTP) | CEDV Smoothing Config | 0x40C7 | EOC Smooth Current | U1 | 0 | 10 | 2 | 0.1% |
| Gas Gauging (Present OTP) | CEDV Smoothing Config | 0x40C8 | EOC Smooth Current Time | U1 | 0 | 255 | 60 | s |
| Calibration (ROM Default) | Offset | 0x4800 | Board Offset | I1 | -128 | 127 | 0 | Counts |
| Calibration (ROM Default) | Offset | 0x4801 | Int Temp Offset | I1 | -128 | 127 | 0 | 0.1°C |
| Calibration (ROM Default) | Offset | 0x4802 | Ext Temp Offset | I1 | -128 | 127 | 0 | 0.1°C |
| Calibration (ROM Default) | Offset | 0x4803 | Pack V Offset | I1 | -128 | 127 | 0 | mV |
| Calibration (ROM Default) | Temperature | 0x4804 | Internal Model Coefficient 1 | I2 | -32768 | 32767 | 0 | Num |
| Calibration (ROM Default) | Temperature | 0x4806 | Internal Model Coefficient 2 | I2 | -32768 | 32767 | 0 | Num |
| Calibration (ROM Default) | Temperature | 0x4808 | Internal Model Coefficient 3 | I2 | -32768 | 32767 | -13356 | Num |
| Calibration (ROM Default) | Temperature | 0x480A | Internal Model Coefficient 4 | I2 | -32768 | 32767 | 6661 | Num |
| Calibration (ROM Default) | Temperature | 0x480C | External Model Coefficient 1 | I2 | -32768 | 32767 | -11130 | Num |
| Calibration (ROM Default) | Temperature | 0x480E | External Model Coefficient 2 | I2 | -32768 | 32767 | 19142 | Num |

Table 3-2. Data Memory Table (continued)

| Class | Subclass | Address | Name | Type | Min Value | Max Value | Default | Units |
|-----------------------------|--------------------|---------|--------------------------------|------|-----------|-----------|---------|--------|
| Calibration (ROM Default) | Temperature | 0x4810 | External Model Coefficient 3 | I2 | -32768 | 32767 | -19262 | Num |
| Calibration (ROM Default) | Temperature | 0x4812 | External Model Coefficient 4 | I2 | -32768 | 32767 | 28203 | Num |
| Calibration (ROM Default) | Temperature | 0x4814 | External Model Coefficient 5 | I2 | -32768 | 32767 | 892 | Num |
| Calibration (ROM Default) | Temperature | 0x4816 | External Model Coefficient b 1 | I2 | -32768 | 32767 | 328 | Num |
| Calibration (ROM Default) | Temperature | 0x4818 | External Model Coefficient b 2 | I2 | -32768 | 32767 | -605 | Num |
| Calibration (ROM Default) | Temperature | 0x481A | External Model Coefficient b 3 | I2 | -32768 | 32767 | -2443 | Num |
| Calibration (ROM Default) | Temperature | 0x481C | External Model Coefficient b 4 | I2 | -32768 | 32767 | 4696 | Num |
| Calibration (ROM Default) | Temperature | 0x481E | RC0 | I2 | -32768 | 32767 | 11703 | Counts |
| Calibration (ROM Default) | Temperature | 0x4820 | Voltage Comp Coefficient 1 | I2 | -32768 | 32767 | 7320 | Num |
| Calibration (ROM Default) | Temperature | 0x4822 | Voltage Comp Coefficient 2 | I2 | -32768 | 32767 | 723 | Num |
| Calibration (ROM Default) | Temperature | 0x4824 | Voltage Comp Coefficient 3 | I2 | -32768 | 32767 | -71 | Num |
| Calibration (ROM Default) | Temperature | 0x4826 | Voltage Comp Input Multiplier | U1 | 0 | 255 | 48 | Num |
| Calibration (ROM Default) | Temperature | 0x4827 | Voltage Comp Output Divisor | I2 | -32768 | 32767 | 256 | Num |
| Calibration (ROM Default) | Current | 0x4829 | Filter | U1 | 0 | 255 | 239 | Num |
| Calibration (ROM Default) | Current | 0x482A | Deadband | U1 | 0 | 255 | 5 | mA |
| Calibration (ROM Default) | Current | 0x482B | CC Deadband | U1 | 0 | 255 | 17 | 294 nV |
| Configuration (ROM Default) | Charge Inhibit Cfg | 0x4841 | Chg Inhibit Temp Low | I2 | -400 | 1200 | 0 | 0.1°C |
| Configuration (ROM Default) | Charge Inhibit Cfg | 0x4843 | Chg Inhibit Temp High | I2 | -400 | 1200 | 450 | 0.1°C |
| Configuration (ROM Default) | Charge Inhibit Cfg | 0x4845 | Temp Hys | I2 | 0 | 100 | 50 | 0.1°C |
| Configuration (ROM Default) | Charge | 0x4847 | Charging Current | I2 | 0 | 1000 | 200 | mA |
| Configuration (ROM Default) | Charge | 0x4849 | Charging Voltage | I2 | 0 | 4600 | 4200 | mV |
| Configuration (ROM Default) | Charge Termination | 0x484D | Taper Current | I2 | 0 | 1000 | 100 | mA |
| Configuration (ROM Default) | Safety | 0x487E | OT Chg | I2 | 0 | 1200 | 550 | 0.1°C |
| Configuration (ROM Default) | Safety | 0x4880 | OT Chg Time | U1 | 0 | 60 | 2 | s |
| Configuration (ROM Default) | Safety | 0x4881 | OT Chg Recovery | I2 | 0 | 1200 | 500 | 0.1°C |
| Configuration (ROM Default) | Safety | 0x4883 | OT Dsg | I2 | 0 | 1200 | 600 | 0.1°C |
| Configuration (ROM Default) | Safety | 0x4885 | OT Dsg Time | U1 | 0 | 60 | 2 | s |
| Configuration (ROM Default) | Safety | 0x4886 | OT Dsg Recovery | I2 | 0 | 1200 | 550 | 0.1°C |
| Configuration (ROM Default) | Registers | 0x4852 | Operation Config A | H2 | 0x0000 | 0xFFFF | 0x0484 | Hex |
| Configuration (ROM Default) | Registers | 0x4854 | Operation Config B | H2 | 0x0000 | 0xFFFF | 0x1000 | Hex |

Table 3-2. Data Memory Table (continued)

| Class | Subclass | Address | Name | Type | Min Value | Max Value | Default | Units |
|-----------------------------|---------------------|---------|-------------------------------|------|-----------|-----------|---------|-------|
| Configuration (ROM Default) | Registers | 0x4857 | SOC Delta | U1 | 0 | 25 | 1 | % |
| Configuration (ROM Default) | Registers | 0x4858 | Clk Ctl Reg | H1 | 0x00 | 0x0F | 0x09 | Hex |
| Configuration (ROM Default) | Registers | 0x485E | Device Type | H2 | 0x0000 | 0xFFFF | 0x0220 | Hex |
| Configuration (ROM Default) | BTP | 0x4859 | IO Config | H1 | 0x0 | 0x03 | 0x00 | Hex |
| Configuration (ROM Default) | BTP | 0x485A | Init Discharge Set | I2 | 0 | 32767 | 150 | mAh |
| Configuration (ROM Default) | BTP | 0x485C | Init Charge Set | I2 | 0 | 32767 | 175 | mAh |
| Configuration (ROM Default) | Power | 0x4863 | Sleep Current | I2 | 0 | 100 | 10 | mA |
| Configuration (ROM Default) | Power | 0x4865 | Bus Low Time | U1 | 0 | 255 | 5 | s |
| Configuration (ROM Default) | Power | 0x4866 | Offset Cal Inhibit Temp Low | I2 | -400 | 1200 | 50 | 0.1°C |
| Configuration (ROM Default) | Power | 0x4868 | Offset Cal Inhibit Temp High | I2 | -400 | 1200 | 450 | 0.1°C |
| Configuration (ROM Default) | Power | 0x486A | Sleep Voltage Time | U1 | 0 | 100 | 20 | s |
| Configuration (ROM Default) | Power | 0x486B | Sleep Current Time | U1 | 0 | 255 | 20 | s |
| Configuration (ROM Default) | Power | 0x486C | Hibernate I | U2 | 0 | 700 | 8 | mA |
| Configuration (ROM Default) | Power | 0x486E | Hibernate V | U2 | 2400 | 3000 | 2550 | mV |
| Configuration (ROM Default) | Current Thresholds | 0x4874 | Discharge Detection Threshold | I2 | 0 | 2000 | 60 | mA |
| Configuration (ROM Default) | Current Thresholds | 0x4876 | Charge Detection Threshold | I2 | 0 | 2000 | 75 | mA |
| Configuration (ROM Default) | Current Thresholds | 0x4878 | Quit Current | I2 | 0 | 1000 | 40 | mA |
| Configuration (ROM Default) | Current Thresholds | 0x487A | Discharge Relax Time | U2 | 0 | 8191 | 60 | s |
| Configuration (ROM Default) | Current Thresholds | 0x487C | Charge Relax Time | U1 | 0 | 255 | 60 | s |
| Configuration (ROM Default) | Current Thresholds | 0x487D | Quit Relax Time | U1 | 0 | 63 | 1 | s |
| Configuration (ROM Default) | Data | 0x4888 | Initial Standby | I1 | -127 | 0 | -10 | mA |
| Configuration (ROM Default) | Discharge | 0x488C | SysDown Set Volt Threshold | I2 | 0 | 4200 | 3150 | mV |
| Configuration (ROM Default) | Discharge | 0x488E | SysDown Set Volt Time | U1 | 0 | 60 | 2 | s |
| Configuration (ROM Default) | Discharge | 0x488F | SysDown Clear Volt Threshold | I2 | 0 | 5000 | 3250 | mV |
| Configuration (ROM Default) | SOC | 0x48CB | Flag Config A | H2 | 0x0 | 0x0FFF | 0x0C8C | Hex |
| Configuration (ROM Default) | SOC | 0x48CD | Flag Config B | H1 | 0x0 | 0xFF | 0x8C | Hex |
| Configuration (ROM Default) | CEDV Profile Select | 0x48E6 | Battery ID | H1 | 0x00 | 0x1F | 0x00 | Hex |
| Gas Gauging (ROM Default) | Cycle | 0x48C9 | Cycle Count Percentage | U1 | 0 | 100 | 90 | % |
| Gas Gauging (ROM Default) | FD | 0x48CE | Set Voltage Threshold | I2 | 0 | 5000 | 3000 | mV |
| Gas Gauging (ROM Default) | FD | 0x48D0 | Clear Voltage Threshold | I2 | 0 | 5000 | 3100 | mV |

Table 3-2. Data Memory Table (continued)

| Class | Subclass | Address | Name | Type | Min Value | Max Value | Default | Units |
|---------------------------|--------------------|---------|----------------------------|------|-----------|-----------|---------|--------------|
| Gas Gauging (ROM Default) | FD | 0x48D2 | Set % RSOC Threshold | U1 | 0 | 100 | 0 | % |
| Gas Gauging (ROM Default) | FD | 0x48D3 | Clear % RSOC Threshold | U1 | 0 | 100 | 5 | % |
| Gas Gauging (ROM Default) | FC | 0x48D4 | Set Voltage Threshold | I2 | 0 | 5000 | 4200 | mV |
| Gas Gauging (ROM Default) | FC | 0x48D6 | Clear Voltage Threshold | I2 | 0 | 5000 | 4100 | mV |
| Gas Gauging (ROM Default) | FC | 0x48D8 | Set % RSOC Threshold | U1 | 0 | 100 | 100 | % |
| Gas Gauging (ROM Default) | FC | 0x48D9 | Clear % RSOC Threshold | U1 | 0 | 100 | 95 | % |
| Gas Gauging (ROM Default) | TD | 0x48DA | Set Voltage Threshold | I2 | 0 | 5000 | 3200 | mV |
| Gas Gauging (ROM Default) | TD | 0x48DC | Clear Voltage Threshold | I2 | 0 | 5000 | 3300 | mV |
| Gas Gauging (ROM Default) | TD | 0x48DE | Set % RSOC Threshold | U1 | 0 | 100 | 6 | % |
| Gas Gauging (ROM Default) | TD | 0x48DF | Clear % RSOC Threshold | U1 | 0 | 100 | 8 | % |
| Gas Gauging (ROM Default) | TC | 0x48E0 | Set Voltage Threshold | I2 | 0 | 5000 | 4200 | mV |
| Gas Gauging (ROM Default) | TC | 0x48E2 | Clear Voltage Threshold | I2 | 0 | 5000 | 4100 | mV |
| Gas Gauging (ROM Default) | TC | 0x48E4 | Set % RSOC Threshold | U1 | 0 | 100 | 100 | % |
| Gas Gauging (ROM Default) | TC | 0x48E5 | Clear % RSOC Threshold | U1 | 0 | 100 | 95 | % |
| Gas Gauging (ROM Default) | CEDV Configuration | 0x489D | Battery Low % | U2 | 0 | 65535 | 700 | .01% |
| Gas Gauging (ROM Default) | CEDV Configuration | 0x48A7 | Learning Low Temp | U1 | 0 | 255 | 119 | 0.1°C |
| Gas Gauging (ROM Default) | CEDV Configuration | 0x48B0 | OverLoad Current | I2 | 0 | 32767 | 1500 | mA |
| Gas Gauging (ROM Default) | CEDV Configuration | 0x48B4 | Self Discharge Rate | U1 | 0 | 255 | 20 | 0.0025% /day |
| Gas Gauging (ROM Default) | CEDV Configuration | 0x48B5 | Electronics Load | I2 | 0 | 255 | 0 | 3 µA |
| Gas Gauging (ROM Default) | CEDV Configuration | 0x48B7 | Near Full | I2 | 0 | 32767 | 200 | mAh |
| Gas Gauging (ROM Default) | CEDV Configuration | 0x48B9 | Reserve Capacity | I2 | 0 | 32767 | 0 | mAh |
| Gas Gauging (ROM Default) | CEDV Configuration | 0x48BB | Chg Eff | U1 | 0 | 100 | 100 | % |
| Gas Gauging (ROM Default) | CEDV Configuration | 0x48BC | Dsg Eff | U1 | 0 | 100 | 100 | % |
| Gas Gauging (ROM Default) | CEDV Profile 1 | 0x48E7 | Gauging Configuration | H2 | 0x0 | 0x1FFF | 0x102A | Hex |
| Gas Gauging (ROM Default) | CEDV Profile 1 | 0x48E9 | Full Charge Capacity | I2 | 0 | 32767 | 3000 | mAh |
| Gas Gauging (ROM Default) | CEDV Profile 1 | 0x48EB | Design Capacity | I2 | 0 | 32767 | 3000 | mAh |
| Gas Gauging (ROM Default) | CEDV Profile 1 | 0x48EF | Design Voltage | I2 | 0 | 32767 | 3700 | mV |
| Gas Gauging (ROM Default) | CEDV Profile 1 | 0x48F1 | Charge Termination Voltage | I2 | 0 | 1000 | 100 | mV |
| Gas Gauging (ROM Default) | CEDV Profile 1 | 0x48F3 | EMF | U2 | 0 | 65535 | 3743 | — |
| Gas Gauging (ROM Default) | CEDV Profile 1 | 0x48F5 | C0 | U2 | 0 | 65535 | 149 | — |

Table 3-2. Data Memory Table (continued)

| Class | Subclass | Address | Name | Type | Min Value | Max Value | Default | Units |
|---------------------------|----------------|---------|----------------------------|------|-----------|-----------|---------|-------|
| Gas Gauging (ROM Default) | CEDV Profile 1 | 0x48F7 | R0 | U2 | 0 | 65535 | 867 | — |
| Gas Gauging (ROM Default) | CEDV Profile 1 | 0x48F9 | T0 | U2 | 0 | 65535 | 4030 | — |
| Gas Gauging (ROM Default) | CEDV Profile 1 | 0x48FB | R1 | U2 | 0 | 65535 | 316 | — |
| Gas Gauging (ROM Default) | CEDV Profile 1 | 0x48FD | TC | U1 | 0 | 255 | 9 | — |
| Gas Gauging (ROM Default) | CEDV Profile 1 | 0x48FE | C1 | U1 | 0 | 255 | 0 | — |
| Gas Gauging (ROM Default) | CEDV Profile 1 | 0x48FF | Age Factor | U1 | 0 | 255 | 0 | — |
| Gas Gauging (ROM Default) | CEDV Profile 1 | 0x4900 | Fixed EDV 0 | I2 | 0 | 32767 | 3031 | mV |
| Gas Gauging (ROM Default) | CEDV Profile 1 | 0x4902 | EDV 0 Hold Time | U1 | 1 | 255 | 1 | s |
| Gas Gauging (ROM Default) | CEDV Profile 1 | 0x4903 | Fixed EDV 1 | I2 | 0 | 32767 | 3385 | mV |
| Gas Gauging (ROM Default) | CEDV Profile 1 | 0x4905 | EDV 1 Hold Time | U1 | 1 | 255 | 1 | s |
| Gas Gauging (ROM Default) | CEDV Profile 1 | 0x4906 | Fixed EDV 2 | I2 | 0 | 32767 | 3501 | mV |
| Gas Gauging (ROM Default) | CEDV Profile 1 | 0x4908 | EDV 2 Hold Time | U1 | 1 | 255 | 1 | s |
| Gas Gauging (ROM Default) | CEDV Profile 1 | 0x4909 | Voltage 0% DOD | I2 | -32768 | 32767 | 4173 | mV |
| Gas Gauging (ROM Default) | CEDV Profile 1 | 0x490B | Voltage 10% DOD | I2 | -32768 | 32767 | 4043 | mV |
| Gas Gauging (ROM Default) | CEDV Profile 1 | 0x490D | Voltage 20% DOD | I2 | -32768 | 32767 | 3925 | mV |
| Gas Gauging (ROM Default) | CEDV Profile 1 | 0x490F | Voltage 30% DOD | I2 | -32768 | 32767 | 3821 | mV |
| Gas Gauging (ROM Default) | CEDV Profile 1 | 0x4911 | Voltage 40% DOD | I2 | -32768 | 32767 | 3725 | mV |
| Gas Gauging (ROM Default) | CEDV Profile 1 | 0x4913 | Voltage 50% DOD | I2 | -32768 | 32767 | 3656 | mV |
| Gas Gauging (ROM Default) | CEDV Profile 1 | 0x4915 | Voltage 60% DOD | I2 | -32768 | 32767 | 3619 | mV |
| Gas Gauging (ROM Default) | CEDV Profile 1 | 0x4917 | Voltage 70% DOD | I2 | -32768 | 32767 | 3582 | mV |
| Gas Gauging (ROM Default) | CEDV Profile 1 | 0x4919 | Voltage 80% DOD | I2 | -32768 | 32767 | 3515 | mV |
| Gas Gauging (ROM Default) | CEDV Profile 1 | 0x491B | Voltage 90% DOD | I2 | -32768 | 32767 | 3439 | mV |
| Gas Gauging (ROM Default) | CEDV Profile 1 | 0x491D | Voltage 100% DOD | I2 | -32768 | 32767 | 2713 | mV |
| Gas Gauging (ROM Default) | CEDV Profile 2 | 0x491F | Gauging Configuration | H2 | 0x0 | 0x1FFF | 0x0000 | Hex |
| Gas Gauging (ROM Default) | CEDV Profile 2 | 0x4921 | Full Charge Capacity | I2 | 0 | 32767 | 2200 | mAh |
| Gas Gauging (ROM Default) | CEDV Profile 2 | 0x4923 | Design Capacity | I2 | 0 | 32767 | 2200 | mAh |
| Gas Gauging (ROM Default) | CEDV Profile 2 | 0x4927 | Design Voltage | I2 | 0 | 32767 | 3700 | mV |
| Gas Gauging (ROM Default) | CEDV Profile 2 | 0x4929 | Charge Termination Voltage | I2 | 0 | 1000 | 100 | mV |
| Gas Gauging (ROM Default) | CEDV Profile 2 | 0x492B | EMF | U2 | 0 | 65535 | 3743 | — |
| Gas Gauging (ROM Default) | CEDV Profile 2 | 0x492D | C0 | U2 | 0 | 65535 | 149 | — |

Table 3-2. Data Memory Table (continued)

| Class | Subclass | Address | Name | Type | Min Value | Max Value | Default | Units |
|---------------------------|----------------|---------|----------------------------|------|-----------|-----------|---------|-------|
| Gas Gauging (ROM Default) | CEDV Profile 2 | 0x492F | R0 | U2 | 0 | 65535 | 867 | — |
| Gas Gauging (ROM Default) | CEDV Profile 2 | 0x4931 | T0 | U2 | 0 | 65535 | 4030 | — |
| Gas Gauging (ROM Default) | CEDV Profile 2 | 0x4933 | R1 | U2 | 0 | 65535 | 316 | — |
| Gas Gauging (ROM Default) | CEDV Profile 2 | 0x4935 | TC | U1 | 0 | 255 | 9 | — |
| Gas Gauging (ROM Default) | CEDV Profile 2 | 0x4936 | C1 | U1 | 0 | 255 | 0 | — |
| Gas Gauging (ROM Default) | CEDV Profile 2 | 0x4937 | Age Factor | U1 | 0 | 255 | 0 | — |
| Gas Gauging (ROM Default) | CEDV Profile 2 | 0x4938 | Fixed EDV 0 | I2 | 0 | 32767 | 3031 | mV |
| Gas Gauging (ROM Default) | CEDV Profile 2 | 0x493A | EDV 0 Hold Time | U1 | 1 | 255 | 1 | s |
| Gas Gauging (ROM Default) | CEDV Profile 2 | 0x493B | Fixed EDV 1 | I2 | 0 | 32767 | 3385 | mV |
| Gas Gauging (ROM Default) | CEDV Profile 2 | 0x493D | EDV 1 Hold Time | U1 | 1 | 255 | 1 | s |
| Gas Gauging (ROM Default) | CEDV Profile 2 | 0x493E | Fixed EDV 2 | I2 | 0 | 32767 | 3501 | mV |
| Gas Gauging (ROM Default) | CEDV Profile 2 | 0x4940 | EDV 2 Hold Time | U1 | 1 | 255 | 1 | s |
| Gas Gauging (ROM Default) | CEDV Profile 2 | 0x4941 | Voltage 0% DOD | I2 | -32768 | 32767 | 4173 | mV |
| Gas Gauging (ROM Default) | CEDV Profile 2 | 0x4943 | Voltage 10% DOD | I2 | -32768 | 32767 | 4043 | mV |
| Gas Gauging (ROM Default) | CEDV Profile 2 | 0x4945 | Voltage 20% DOD | I2 | -32768 | 32767 | 3925 | mV |
| Gas Gauging (ROM Default) | CEDV Profile 2 | 0x4947 | Voltage 30% DOD | I2 | -32768 | 32767 | 3821 | mV |
| Gas Gauging (ROM Default) | CEDV Profile 2 | 0x4949 | Voltage 40% DOD | I2 | -32768 | 32767 | 3725 | mV |
| Gas Gauging (ROM Default) | CEDV Profile 2 | 0x494B | Voltage 50% DOD | I2 | -32768 | 32767 | 3656 | mV |
| Gas Gauging (ROM Default) | CEDV Profile 2 | 0x494D | Voltage 60% DOD | I2 | -32768 | 32767 | 3619 | mV |
| Gas Gauging (ROM Default) | CEDV Profile 2 | 0x494F | Voltage 70% DOD | I2 | -32768 | 32767 | 3582 | mV |
| Gas Gauging (ROM Default) | CEDV Profile 2 | 0x4951 | Voltage 80% DOD | I2 | -32768 | 32767 | 3515 | mV |
| Gas Gauging (ROM Default) | CEDV Profile 2 | 0x4953 | Voltage 90% DOD | I2 | -32768 | 32767 | 3439 | mV |
| Gas Gauging (ROM Default) | CEDV Profile 2 | 0x4955 | Voltage 100% DOD | I2 | -32768 | 32767 | 2713 | mV |
| Gas Gauging (ROM Default) | CEDV Profile 3 | 0x4957 | Gauging Configuration | H2 | 0x0 | 0x1FFF | 0x0000 | Hex |
| Gas Gauging (ROM Default) | CEDV Profile 3 | 0x4959 | Full Charge Capacity | I2 | 0 | 32767 | 2200 | mAh |
| Gas Gauging (ROM Default) | CEDV Profile 3 | 0x495B | Design Capacity | I2 | 0 | 32767 | 2200 | mAh |
| Gas Gauging (ROM Default) | CEDV Profile 3 | 0x495F | Design Voltage | I2 | 0 | 32767 | 3700 | mV |
| Gas Gauging (ROM Default) | CEDV Profile 3 | 0x4961 | Charge Termination Voltage | I2 | 0 | 1000 | 100 | mV |
| Gas Gauging (ROM Default) | CEDV Profile 3 | 0x4963 | EMF | U2 | 0 | 65535 | 3743 | — |
| Gas Gauging (ROM Default) | CEDV Profile 3 | 0x4965 | C0 | U2 | 0 | 65535 | 149 | — |

Table 3-2. Data Memory Table (continued)

| Class | Subclass | Address | Name | Type | Min Value | Max Value | Default | Units |
|---------------------------|-----------------------|---------|-------------------------|------|-----------|-----------|---------|-------|
| Gas Gauging (ROM Default) | CEDV Profile 3 | 0x4967 | R0 | U2 | 0 | 65535 | 867 | — |
| Gas Gauging (ROM Default) | CEDV Profile 3 | 0x4969 | T0 | U2 | 0 | 65535 | 4030 | — |
| Gas Gauging (ROM Default) | CEDV Profile 3 | 0x496B | R1 | U2 | 0 | 65535 | 316 | — |
| Gas Gauging (ROM Default) | CEDV Profile 3 | 0x496D | TC | U1 | 0 | 255 | 9 | — |
| Gas Gauging (ROM Default) | CEDV Profile 3 | 0x496E | C1 | U1 | 0 | 255 | 0 | — |
| Gas Gauging (ROM Default) | CEDV Profile 3 | 0x496F | Age Factor | U1 | 0 | 255 | 0 | — |
| Gas Gauging (ROM Default) | CEDV Profile 3 | 0x4970 | Fixed EDV 0 | I2 | 0 | 32767 | 3031 | mV |
| Gas Gauging (ROM Default) | CEDV Profile 3 | 0x4972 | EDV 0 Hold Time | U1 | 1 | 255 | 1 | s |
| Gas Gauging (ROM Default) | CEDV Profile 3 | 0x4973 | Fixed EDV 1 | I2 | 0 | 32767 | 3385 | mV |
| Gas Gauging (ROM Default) | CEDV Profile 3 | 0x4975 | EDV 1 Hold Time | U1 | 1 | 255 | 1 | s |
| Gas Gauging (ROM Default) | CEDV Profile 3 | 0x4976 | Fixed EDV 2 | I2 | 0 | 32767 | 3501 | mV |
| Gas Gauging (ROM Default) | CEDV Profile 3 | 0x4978 | EDV 2 Hold Time | U1 | 1 | 255 | 1 | s |
| Gas Gauging (ROM Default) | CEDV Profile 3 | 0x4979 | Voltage 0% DOD | I2 | -32768 | 32767 | 4173 | mV |
| Gas Gauging (ROM Default) | CEDV Profile 3 | 0x497B | Voltage 10% DOD | I2 | -32768 | 32767 | 4043 | mV |
| Gas Gauging (ROM Default) | CEDV Profile 3 | 0x497D | Voltage 20% DOD | I2 | -32768 | 32767 | 3925 | mV |
| Gas Gauging (ROM Default) | CEDV Profile 3 | 0x497F | Voltage 30% DOD | I2 | -32768 | 32767 | 3821 | mV |
| Gas Gauging (ROM Default) | CEDV Profile 3 | 0x4981 | Voltage 40% DOD | I2 | -32768 | 32767 | 3725 | mV |
| Gas Gauging (ROM Default) | CEDV Profile 3 | 0x4983 | Voltage 50% DOD | I2 | -32768 | 32767 | 3656 | mV |
| Gas Gauging (ROM Default) | CEDV Profile 3 | 0x4985 | Voltage 60% DOD | I2 | -32768 | 32767 | 3619 | mV |
| Gas Gauging (ROM Default) | CEDV Profile 3 | 0x4987 | Voltage 70% DOD | I2 | -32768 | 32767 | 3582 | mV |
| Gas Gauging (ROM Default) | CEDV Profile 3 | 0x4989 | Voltage 80% DOD | I2 | -32768 | 32767 | 3515 | mV |
| Gas Gauging (ROM Default) | CEDV Profile 3 | 0x498B | Voltage 90% DOD | I2 | -32768 | 32767 | 3439 | mV |
| Gas Gauging (ROM Default) | CEDV Profile 3 | 0x498D | Voltage 100% DOD | I2 | -32768 | 32767 | 2713 | mV |
| Gas Gauging (ROM Default) | CEDV Smoothing Config | 0x48BD | Smoothing Config | H1 | 0x00 | 0xFF | 0x08 | Hex |
| Gas Gauging (ROM Default) | CEDV Smoothing Config | 0x48BE | Smoothing Start Voltage | I2 | 0 | 4300 | 3700 | mV |
| Gas Gauging (ROM Default) | CEDV Smoothing Config | 0x48C0 | Smoothing Delta Voltage | I2 | 0 | 4200 | 100 | mV |
| Gas Gauging (ROM Default) | CEDV Smoothing Config | 0x48C2 | Max Smoothing Current | I2 | 0 | 32767 | 8000 | mA |
| Gas Gauging (ROM Default) | CEDV Smoothing Config | 0x48C7 | EOC Smooth Current | U1 | 0 | 10 | 2 | 0.1% |
| Gas Gauging (ROM Default) | CEDV Smoothing Config | 0x48C8 | EOC Smooth Current Time | U1 | 0 | 255 | 60 | s |

Functional Description

4.1 Device Configuration

The configuration options are configured via the following **Operation Configuration A** and **Operation Configuration B** data memory registers. These registers are programmed and read via the methods described in [Section 3.1, Accessing the Data Memory](#).

4.1.1 CEDV Smoothing Config Register

Table 4-1. CEDV Smoothing Config Register Bit Definition

| | Bit 7 | Bit 6 | Bit 5 | Bit 4 | Bit 3 | Bit 2 | Bit 1 | Bit 0 |
|----------------|-------------|-------|-------|-------|---------------|-------|-------|-------|
| | RSVD | RSVD | RSVD | RSVD | SMOOTH EOC_EN | SMEXT | VAVG | SMEN |
| Default | 0 | 0 | 0 | 0 | 0 | 0 | 0 | 0 |
| | 0x00 | | | | | | | |

RSVD = Reserved

SMOOTHEOC_EN = Allows smoothing of Remcap once Current starts decreasing during the end of charge (EOC).

0 = End of charge smoothing is not enabled.

1 (default) = End of charge smoothing is enabled.

SMEXT = When set to 1, smoothing continues to EDV1 and EDV0 points. When set to 0, smoothing stops at EDV2. Default is 0.

VAVG = Enables smoothing to use average voltage

When set to 1, smoothing uses average voltage. When set to 0 smoothing uses measured voltage. Default is 0.

SMEN = Smoothing result is reported on *RemainingCapacity()*.

When set to 1, the smoothing result is reported on *RemainingCapacity()*. When set to 0, the normal CEDV remaining capacity is reported. Default is 0.

4.1.2 Operation Configuration A (Operation Config A) Register

Table 4-2. Operation Config A Register Bit Definition

| | Bit 7 | Bit 6 | Bit 5 | Bit 4 | Bit 3 | Bit 2 | Bit 1 | Bit 0 |
|------------------|-------------|-------|-----------|----------|----------|---------|-------------|--------|
| High Byte | TEMPS | RSVD | BATG_POL | BATG_EN | RSVD | SLEEP | SLPWAKEC HG | WRTEMP |
| Default | 0 | 0 | 0 | 0 | 0 | 1 | 0 | 0 |
| | 0x04 | | | | | | | |
| Low Byte | BIEnable | RSVD | BI_PUP_EN | PFC_CFG1 | PFC_CFG0 | WAKE_EN | WK_TH1 | WK_TH0 |
| Default | 1 | 0 | 0 | 0 | 0 | 1 | 0 | 0 |
| | 0x04 | | | | | | | |

High Byte

- TEMPS = When set to 1, the external thermistor is selected for *Temperature()* measurements.
- RSVD = Reserved. Do not use.
- BATG_POL = BAT_GD pin polarity control. Active-low is 0. Active-high is 1.
- BATG_EN = Enables BATT_GD functionality
- RSVD = Reserved
- SLEEP = The fuel gauge can enter SLEEP, if operating conditions allow. True when set.
- SLPWAKECHG = Accumulate estimated charge on wake from sleep when *Current()* > **Sleep Current** but not enough to trigger wake event. Enabled when set.
- WRTEMP = Enables the temperature write. The temperature is expected to be written by the host and is used for gauging. Neither the external thermistor or internal temperature sensor is used. True when set. (May not be fully implemented.)

Low Byte

- BIEnable = When enabled, the fuel gauge detects battery insertion using the TS pin. If disabled, the fuel gauge relies on the host to set and clear the *BatteryStatus()[BATTPRES]* bit using *BAT_INSERT()* or *BAT_REMOVE()* subcommands. True when set.
- RSVD = Reserved. Do not use.
- BI_PUP_EN = Battery insertion pin pull up enable
- PFC_CFG1, PFC_CFG0 = Pin function code (PFC) mode selection: PFC 0, 1, 2, or 3 selected by 00, 01, 10, or 11, respectively (see [Section 4.2.1, Pin Function Code \(PFC\) Descriptions](#)).
- WAKE_EN,WK_TH1,WK_TH0 = These bits configure the current wake function. See the *bq27220 System-Side CEDV Fuel Gauge Data Sheet (SLUSCB7)* for threshold values.

4.1.3 Operation Configuration B (Operation Config B) Register

Table 4-3. Operation Config B Register Bit Definitions

| | Bit 7 | Bit 6 | Bit 5 | Bit 4 | Bit 3 | Bit 2 | Bit 1 | Bit 0 |
|------------------|-------------|----------|-----------|---------|--------------|--------|---------|----------|
| High Byte | RSVD | RSVD | RSVD | RSVD | Default Seal | NR | RSVD | RSVD |
| Default | 0 | 0 | 0 | 1 | 0 | 0 | 0 | 0 |
| | 0x10 | | | | | | | |
| Low Byte | INT_BREM | INT_BATL | INT_STATE | INT_OCV | RSVD | INT_OT | INT_POL | INT_FOCV |
| Default | 0 | 0 | 0 | 0 | 0 | 0 | 0 | 0 |
| | 0x00 | | | | | | | |

High Byte

- Default Seal = Seal during POR.
- 0 = No Seal after POR (default)
- 1 = Seal after POR

NR = Non Removable

Low Byte

- INT_BREM = The GPOUT pulses 1 ms when the battery is removed and **[BIEnable]** = 1. Enabled when set.
- INT_BATL = Enables toggle of the GPOUT pin upon TDA getting set
- INT_STATE = Enables the SOC_INT function to pulse the GPOUT pin on current direction change
- INT_OCV = Enables the SOC_INT function to generate a pulse due to OCV command
- RSVD = Reserved
- INT_OT = Enables the SOC_INT function to generate a pulse due to overtemperature conditions in conjunction with the assertion of *BatteryStatus()[OTC or OTD]*
- INT_POL = GPOUT pin polarity control. Active-low is 0. Active-high is 1.
- INT_FOCV = The GPOUT pulses during the first measurement if this bit is set.

4.2 External Pin Functions

4.2.1 Pin Function Code (PFC) Descriptions

This fuel gauge has several pin-function configurations available for the end application. Each configuration is assigned a pin function code, or PFC, specified by the **Operation Config A [PFC_CFG1, PFC_CFG0]** bits (see [Table 4-4](#)). If the fuel gauge is configured to measure external temperature via the **Operation Config A [TEMPS]** bit, a voltage bias of approximately 125 ms is applied periodically to the external thermistor network in order to make a temperature measurement.

Table 4-4. Pin Function Code Summary

| PFC | PFC_CFG [1:0] | External Thermistor Bias Rate ([TEMPS] = 1 only) | | | BAT_GD Pin Usage for PFC | Pin Function Description |
|-----|---------------|--|--------|--------|--|--|
| | | Discharge | Charge | Sleep | | |
| 0 | 00 | 1/s | 1/s | 1/20 s | NA | A dedicated external thermistor is used for the fuel gauge to monitor battery temperature in all conditions. The BAT_GD pin is not used to interface with a charger IC. |
| 1 | 01 | | | | Temperature-based Charge Inhibit | A dedicated external thermistor is used for the fuel gauge to monitor battery temperature in all conditions. If battery charging temperature falls outside of the preset range defined in data memory, a charger can be disabled via the BAT_GD pin until cell temperature recovers. See Section 4.4.2, Charge Inhibit , for additional details. |
| 2 | 10 | | None | | A shared external thermistor is supported between the fuel gauge and a charger IC; however, the BAT_GD pin is not used to interface with the charger IC. The fuel gauge biases the thermistor for battery temperature measurement and BAT_INSERT_CHECK mode (if Operation Config B [BIEnable] bit = 1) under discharge and relaxation conditions only so the charger IC can separately bias the thermistor during CHARGE mode. Bias networks required by the fuel gauge and the charger for the thermistor must be identical. | |
| 3 | 11 | | 1/s | | Follows <i>BatteryStatus()[FC]</i> flags bit | Disables a battery charger IC when fuel gauge has determined the battery is fully charged. The BAT_GD pin reflects the logical status of the <i>BatteryStatus()[FC]</i> bit and is typically connected directly to the charger Charge Enable/Disable (CE/CD) pin or via a network to drive the charger Temperature Sense (TS) pin. |

4.2.2 Battery Presence Detection Using the BIN/TOUT Pin

During power-up or any other activity where the fuel gauge needs to determine whether or not a battery is connected, the fuel gauge applies a test for battery presence when the **Operation Config B [BIEnable]** bit is set.

[Table 4-5](#) details the **Operation_Config [BIEnable]** bit functions.

Table 4-5. Operation_Config [BIEnable] Functions

| Operation_Config | Battery Insertion Requirement | Battery Removal Requirement [BIEnable] |
|------------------|---|---|
| 1 | (1) Host drives BIN pin from logic high to low to signal battery insertion. or (2) A weak pullup resistor can be used (between BIN and V _{CC} pins). When a battery pack with a pulldown resistor is connected, it can generate a logic low to signal battery insertion. | (1) Host drives the BIN pin from logic low to high to signal battery removal. or (2) When a battery pack with a pulldown resistor is removed, the weak pullup resistor can generate a logic high to signal battery removal. |
| 0 | Host sends <i>BAT_INSERT</i> subcommand to signal. | Host sends <i>BAT_REMOVE</i> subcommand to signal battery insertion (battery removal). |

4.2.3 SOC_INT Pin Behavior

The SOC_INT pin generates a pulse of different pulse widths under various conditions as indicated by Table 4-6. After initialization, only one SOC_INT pulse is generated within any given 1-s time slot and, therefore, may indicate multiple event conditions.

Table 4-6. SOC_INT Pulse Conditions and Widths

| Pulse Condition | Enable Condition | Pulse Width | Comment |
|--|---|---|---|
| Change of <i>StateOfCharge()</i> | $(SOC\ Delta) \neq 0$ | 1 ms | During charge, when the SOC is greater than (>) the points: $100\% - n \times (SOC\ Delta)$ and 100%; During discharge, when the SOC reaches (\leq) the points: $100\% - n \times (SOC\ Delta)$ and 0%; where n is an integer starting from 0 to the number generating SOC no less than 0%. Examples: For SOC Delta = 1% (default), the SOC_INT intervals are 0%, 1%, 2%, ..., 99%, and 100%. For SOC Delta = 10%, the SOC_INT intervals are 0%, 10%, 20%, ..., 90%, and 100%. |
| <i>BatteryStatus()</i> [SYSDO WN] set | Always | 1 ms | When the <i>Voltage()</i> has reached SysDown Set Volt Threshold |
| Battery State Change | $(SOC\ Delta) \neq 0$ and Operation Config B [INT_STATE] = 1 | 1 ms | Upon detection of a state change in battery charging and discharging |
| Battery Removal | Operation Config A [BIEnable] = 1 and Operation Config B [INT_BREM] = 1 | 1 ms | |
| OCV measurement after initialization | Operation Config B [INT_FOCV] = 1 | Approximately 625 ms | Within 1.5 seconds after a POR event, <i>RESET()</i> subcommand, or battery insertion event (either via <i>BATT_INSERT()</i> subcommand or battery present pin), SOC_INT begins a pulse for the duration of the OCV measurement and initialization time period. |
| OCV measurement from <i>OCV_CMD()</i> subcommand | Operation Config B [INT_OCV] = 1 | If BATG_EN = 0, pulse width = ~512 ms, else pulse width = 380 ms | Within 1 second after receipt of <i>OCV_CMD()</i> subcommand, SOC_INT begins a pulse for the duration of the OCV measurement execution time period. |
| <i>BatteryStatus()</i> [OTC or OTD] | Operation Config B [INT_OT] = 1 | 1 ms | Upon first assertion of <i>BatteryStatus()</i> [OTC or OTD] overtemperature conditions |
| <i>BatteryStatus()</i> [TDA] | Operation Config B [INT_BATL] = 1 | 1 ms | On change of <i>BatteryStatus()</i> [TDA] |

4.2.4 Power Path Control With the BAT_GD Pin

The fuel gauge must operate in conjunction with other electronics in a system appliance, such as chargers or other ICs and application circuits that draw appreciable power. After a battery is inserted into the system, it is preferable that no charging current or discharging current higher than C/20 is present, so that an accurate OCV can be read. The OCV reading determines the initial SOC so accuracy of the OCV reading directly impacts the starting SOC. To disable these functions, the BAT_GD pin can be connected to the Charger Enable/Disable (CE/CD) pin to disable the charging function. Once an OCV reading has been made, the BAT_GD pin is asserted, thereby enabling battery charging and regular discharge of the battery. The **Operation Config A [BATG_POL]** bit can change the polarity of the BAT_GD pin in case the default configuration needs to be changed for the system application.

Figure 4-1 details how the BAT_GD pin functions in the context of battery insertion and removal, as well as NORMAL versus SLEEP modes.

In PFC 1, the BAT_GD pin also disables battery charging when the fuel gauge reads battery temperatures outside the range defined by [**Charge Inhibit Temp Low, Charge Inhibit Temp High**]. The BAT_GD line is asserted once temperature falls within the range [**Charge Inhibit Temp Low + Temp Hys, Charge Inhibit Temp High – Temp Hys**].

4.2.5 Battery Trip Point (BTP) Interrupts

The Battery Trip Point (BTP) feature provides the function to dynamically update capacity-based interrupt thresholds using the *BTPDischargeSet()* and *BTPChargeSet()* commands. Two thresholds are supported: one for crossings in the discharge direction (*RemainingCapacity()* < *BTPDischargeSet()*), and the other used for the charge direction (*RemainingCapacity()* > *BTPChargeSet()*). When a given threshold is breached in the correct current direction, the *OperationStatus[BTPINT]* flag will set to 1 and an interrupt

triggered on GPOUT. Afterwards, writing a new threshold value to either *BTPDischargeSet()* or *BTPChargeSet()* will clear the *OperationStatus[BTPINT]* flag and de-assert the interrupt. The feature is enabled via the **Settings:Configuration:IO Config[BTP_EN]** bit and the polarity of the interrupt configured using **Settings:Configuration:IO Config[BTP_POL]** where setting to 1 selects active-high and clearing to 0 yields active-low assertion behavior on GPOUT. It should be further noted that the logic governing trigger of BTP interrupts is dependent on both threshold crossings AND current direction. More specifically, *OperationStatus[BTPINT]* is set to 1 and a BTP pin interrupt triggered when:

- *RemainingCapacity() < BTPDischargeSet() AND Current() ≤ 0* OR
- *RemainingCapacity() < BTPDischargeSet() AND Current() > 0*

At power-on reset, initialization values for *BTPDischargeSet()* and *BTPChargeSet()* are sourced from **Settings:BTP:Init Discharge Set** and **Settings:BTP:Init Charge Set**, respectively.

Table 4-7. BTP IO Config Register Bit Definition

| | Bit 7 | Bit 6 | Bit 5 | Bit 4 | Bit 3 | Bit 2 | Bit 1 | Bit 0 |
|----------------|-------------|-------|-------|-------|-------|-------|-----------|----------|
| | RSVD | RSVD | RSVD | RSVD | RSVD | RSVD | BtpIntPol | BTPIntEn |
| Default | 0 | 0 | 0 | 0 | 0 | 0 | 0 | 0 |
| | 0x00 | | | | | | | |

RSVD = Reserved

BtpIntPol = BTP Interrupt Polarity

1 = Active High

0 = Active Low

BTPIntEn = BTP Interrupt Enable

1 = BTP Interrupts enabled

0 = BTP Interrupts disabled

Note: If BTP Interrupts is enabled, then the GPOUT pin is dedicated solely to BTP interrupts.

4.2.6 Wake-Up Comparator

The wake-up comparator indicates a change in cell current while the fuel gauge is in SLEEP mode. The **Operation Config A [WK_TH1:WK_TH0]** bits select the appropriate comparator threshold for the sense resistor value used. The **Operation Config A [WAKE_EN]** bit selects one of two possible voltage threshold ranges for the given sense resistor selection. An internal interrupt is generated when the threshold is reached in either the charge or discharge direction. Setting both **[WK_TH1]** and **[WK_TH0]** bits to 0 disables this feature.

4.2.7 Autocalibration

The fuel gauge provides an autocalibration feature that measures the voltage offset error across SRP and SRN as operating conditions change. It subtracts the resulting offset error from the normal sense resistor voltage, V_{SR} , for maximum measurement accuracy.

Autocalibration of the coulomb counter begins on entry to SLEEP mode, except if *Temperature()* is $\leq 5^{\circ}\text{C}$ or *Temperature()* $\geq 45^{\circ}\text{C}$.

The fuel gauge also performs a single offset when:

- The condition of *AverageCurrent()* ≤ 100 mA
- {voltage change since last offset calibration ≥ 256 mV} or {temperature change since last offset calibration is greater than 8°C for ≥ 60 s}.

Capacity and current measurements continue at the last measured rate during the offset calibration when these measurements cannot be performed. If the battery voltage drops more than 32 mV during the offset calibration, the load current has likely increased; thus, the offset calibration is stopped. The *CONTROL_STATUS()[CCA]* bit is set during coulomb counter autocalibration.

4.3 Temperature Measurement

The fuel gauge typically measures battery temperature via its BIN input to supply battery temperature status information to the gas gauging algorithm and charger-control sections of the gauge. Alternatively, it can be configured to use an internal on-chip temperature sensor or receive temperature data from the host processor. See [Section 2.4, Temperature\(\): 0x06 and 0x07](#), for specific information on configuration options. Regardless of which temperature configuration is used, the host processor can request the current battery temperature by reading the *Temperature()*, and for internal temperature, *InternalTemperature()*.

The external thermistor circuit requires the use of an 10K NTC 103AT-type thermistor.

4.3.1 Overtemperature Indication

4.3.1.1 Overtemperature: Charge

If during charging, *Temperature()* reaches the threshold of **OT Chg** for a period of **OT Chg Time**, and *Current()* > **Chg Current Threshold**, then the *BatteryStatus()[OTC]* bit is set. When *Temperature()* falls to **OT Chg Recovery**, the *BatteryStatus()[OTC]* bit is cleared.

If **OT Chg Time** = 0, then the feature is completely disabled.

4.3.1.2 Overtemperature: Discharge

If during discharging, *Temperature()* reaches the threshold of **OT Dsg** for a period of **OT Dsg Time**, and *Current()* ≤ **-Dsg Current Threshold**, then the *BatteryStatus()[OTD]* bit is set. When *Temperature()* falls to **OT Dsg Recovery**, the *BatteryStatus()[OTD]* bit is cleared.

If **OT Dsg Time** = 0, then the feature is completely disabled.

4.4 Charging and Charge Termination Indication

4.4.1 Detecting Charge Termination

For proper fuel gauge operation, the cell **Charging Voltage** must be specified by the user.

The fuel gauge detects charge termination when:

- During two consecutive periods of 40 seconds, the *AverageCurrent()* < **Taper Current**.
- During the same two periods, the accumulated change in capacity must be > 0.25 mAh.
- *Voltage()* > **Charging Voltage – Taper Voltage**.

When this occurs, the *BatteryStatus()[FC]* and *[TCA]* bits are set depending on the **SOC Flag Config A [FCSETVCT]** and **[TCSETVCT]** options. Also, if the **CEDV Configuration [CSYNC]** bit is set, then *RemainingCapacity()* is set equal to *FullChargeCapacity()*.

4.4.2 Charge Inhibit

The fuel gauge can indicate when battery temperature has fallen below or risen above predefined thresholds **Charge Inhibit Temp Low** or **Charge Inhibit Temp High**, respectively. In this mode, the *BatteryStatus()[CHGINH]* bit is set to indicate this condition. The *[CHGINH]* bit is cleared once the battery temperature returns to the range **[Charge Inhibit Temp Low + Temp Hys, Charge Inhibit Temp High – Temp Hys]**.

When *BatteryStatus()[CHGINH]* is set and **[PFC_CFG]** = 1, the BAT_GD pin is deasserted. Otherwise, when *[CHGINH]* is clear if **[OCV_GD]** is set and **[PFC_CFG]** ≠ 0, the BAT_GD pin is asserted.

The charging should not start when the temperature is below the **Charge Inhibit Temp Low** or above the **Charge Inhibit Temp High**. The charging can continue if the charging starts inside the window **[Charge Inhibit Temp Low, Charge Inhibit Temp High]**.

4.5 Power Modes

The fuel gauge has different power modes: NORMAL, SLEEP, CONFIG_UPDATE, and BAT INSERT CHECK.

- In NORMAL mode, the fuel gauge is fully powered and can execute any allowable task.
- In SLEEP mode, the fuel gauge turns off the high-frequency oscillator and exists in a reduced-power state, periodically taking measurements and performing calculations.
- In CONFIG_UPDATE mode, the internal configuration data in the fuel gauge can be modified.
- BAT INSERT CHECK mode is a powered up, but low-power halted, state, where the fuel gauge resides when no battery is inserted into the system.

Figure 4-1 shows the relationship between these modes.

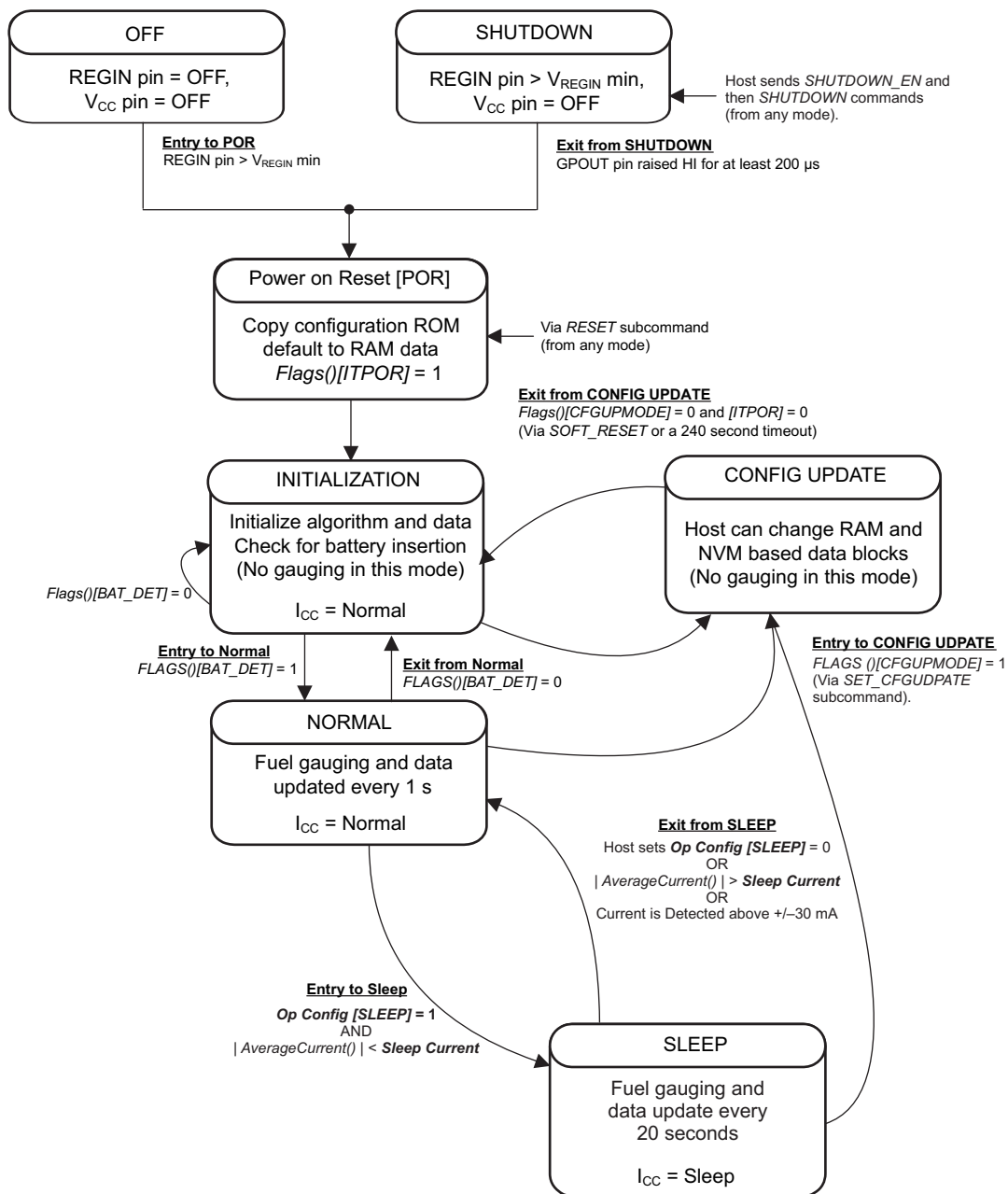

Figure 4-1. Power Mode Diagram for System Shutdown

4.5.1 NORMAL Mode

The fuel gauge is in NORMAL mode when not in any other power mode. During this mode, *Current()*, *Voltage()*, and *Temperature()* measurements are taken, and the interface data set is updated. Decisions to change states are also made. This mode is exited by activating a different power mode.

Because the gauge consumes the most power in the NORMAL mode, the CEDV algorithm minimizes the time the fuel gauge remains in this mode.

4.5.2 SLEEP Mode

SLEEP mode is entered automatically if the feature is enabled (**Operation Config A [SLEEP]** bit = 1) and *Current()* is below the programmable level **Sleep Current**. Once entry into SLEEP mode has been qualified, but prior to entering it, the fuel gauge performs a coulomb counter autocalibration to minimize offset.

During SLEEP mode, the fuel gauge periodically takes data measurements and updates its data set. However, a majority of its time is spent in an idle condition.

The fuel gauge exits the SLEEP mode if any entry condition is broken, specifically when either:

- *Current()* rises above **Sleep Current**.
- A current in excess of I_{WAKE} through R_{SENSE} is detected.

In the event that a battery is removed from the system while a charger is present (and powering the gauge), CEDV updates are not necessary. Thus, the fuel gauge enters a state that checks for battery insertion and does not continue executing the CEDV algorithm.

4.6 CONFIG UPDATE Mode

If the application requires different configuration data for the fuel gauge, the system processor can update RAM-based data memory parameters using the *Control()* **SET_CFGUPDATE** subcommand to enter the CONFIG UPDATE mode. Operation in this mode is indicated by the *Flags()* **[CFGUPMODE]** status bit. In this mode, fuel gauging is suspended while the host uses the extended data commands to modify the configuration data blocks. To resume fuel gauging, the host sends a *Control()* **SOFT_RESET**, **EXIT_CFGUPMODE**, or **EXIT_RESIM** subcommand to exit the CONFIG UPDATE mode, which clears both *Flags()* **[ITPOR]** and **[CFGUPMODE]** bits. After a timeout of approximately 240 seconds (4 minutes), the gauge will automatically exit the CONFIG UPDATE mode if it has not received a **SOFT_RESET**, **EXIT_CFGUPMODE**, or **EXIT_RESIM** subcommand from the host.

NOTE: Because the bq27220 device does not support HIBERNATE mode, it is highly recommended to set **Hibernate I** to 0. To set **Hibernate I** to 0, do the following set of commands:

1. Write 0x0090 to 0x3E (enter CONFIG UPDATE mode), and wait 1100 ms for it to fully enter CONFIG UPDATE mode.
 2. Write (hex) 21 92 00, starting at 0x3E.
 3. Write (hex) 4C 05, starting at 0x61.
 4. Write 0x0091 to 0x3E (exit CONFIG UPDATE reinit).
-

4.7 BAT INSERT CHECK Mode

This mode is a halted-CPU state that occurs when an adapter or other power source is present to power the fuel gauge (and system), yet no battery has been detected. If enabled via the **Operation Config B [BIEnable]** bit, the fuel gauge detects battery insertion either through use of the thermistor network or the BIN pin. Alternatively, the host can use the **BAT_INSERT()** and **BAT_REMOVE()** subcommands to inform the battery presence or removal status. When battery insertion is detected, a series of initialization activities begin, which include: OCV measurement, setting the BAT_GD pin, and selecting the appropriate battery profiles.

Some commands, issued by a system processor, can be processed while the fuel gauge is halted in this mode. The gauge wakes up to process the command, then returns to the halted state awaiting battery insertion.

4.8 Application-Specific Information

4.8.1 Battery Profile Storage and Selection

The fuel gauge supports three pre-defined CEDV profiles in device ROM that customers can use by sending the SET_PROFILE_1/2/3.

In situations where the user wants to input a custom CEDV profile, they can do so by programming the device OTP. The fuel gauge provides OTP space for three profiles. Once the user has programmed the custom profile, the fuel gauge can be instructed to use that profile by sending the SET_PROFILE_4/5/6.

To send these commands, the gauge must be in CONFIG_UPDATE mode.

4.8.2 First OCV Measurement

Upon power-up or pack insertion, an open-circuit voltage (OCV) measurement of the battery is made via the BAT pin. For best gauging results, the system load during the OCV measurement should not exceed a C/20 discharge rate of the battery. For this first critical measurement, both BAT_GD and SOC_INT pins are available for system synchronization. (See [Section 4.2.4, Power Path Control With the BAT_GD Pin](#), [Section 4.2.3, SOC_INT Pin Behavior](#), and [Section 2.1.8, OCV_CMD: 0x000C](#).)

Upon completion of the OCV voltage measurement, the *BatteryStatus()[OCVCOMP]* is set.

4.9 Additional Data Memory Parameter Descriptions

4.9.1 Calibration

The calibration method requires a correction due to offset errors, using a number of samples to get a statistical average for the golden image. The parameters of particular interest are listed below.

NOTE: Calibrate the gauge only when it is in FULL ACCESS UNSEALED mode.

4.9.1.1 CC Gain

CC Gain sets the mA current scale factor for the coulomb counter. Use calibration routines to set this value.

4.9.1.2 CC Delta

CC Delta sets the mAh capacity scale factor for the coulomb counter. Use calibration routines to set this value.

4.9.1.3 Coulomb Counter Offset

This register value stores the coulomb counter offset compensation. It is set by automatic calibration of the device.

4.9.2 Board Offset

This register value stores the compensation for the PCB dependant coulomb counter offset. It is recommended to use characterization data of the actual PCB to set this value.

4.9.3 Int Temp Offset

This register value stores the internal temperature sensor offset compensation. Use calibration routines to set this value.

4.9.4 Ext Temp Offset

This register value stores the external temperature sensor offset compensation. Use calibration routines to set this value.

4.9.5 Pack VOffset

This register value stores the Pack voltage offset measured at the Pack pin. Use calibration routines to set this value.

4.9.6 Internal Temp Model

These values characterize the internal thermistor of the device. Do not modify these values without consulting TI.

Table 4-8. Int Coef 1..4, Int Min AD, Int Max Temp

| Subclass Name | Name | Format | Size in Bytes | Min Value | Max Value | Default Value | Unit |
|---------------|--------------|----------------|---------------|-----------|-----------|---------------|------|
| Temp Model | Int Coef 1 | Signed Integer | 2 | -32768 | 32767 | 0 | |
| | Int Coef 2 | | | | | 0 | |
| | Int Coef 3 | | | | | -12324 | |
| | Int Coef 4 | | | | | 6131 | 0.1K |
| | Int Min AD | | | | | 0 | |
| | Int Max Temp | | | | | 6131 | 0.1K |

4.9.7 Ext a Coef and Ext b Coef

| Subclass ID | Offset | Type | Name | Min | Max | Default | Unit | |
|-------------|--------|------|------|--------------|--------|---------|--------|-----|
| Data | 104 | 4 | I2 | Ext a Coef 1 | -32768 | 32767 | -11130 | Num |
| Data | 104 | 6 | I2 | Ext a Coef 2 | -32768 | 32767 | 19142 | Num |
| Data | 104 | 8 | I2 | Ext a Coef 3 | -32768 | 32767 | -19262 | Num |
| Data | 104 | 10 | I2 | Ext a Coef 4 | -32768 | 32767 | 28203 | Num |
| Data | 104 | 12 | I2 | Ext a Coef 5 | -32768 | 32767 | 892 | Num |
| Data | 104 | 14 | I2 | Ext b Coef 1 | -32768 | 32767 | 328 | Num |
| Data | 104 | 16 | I2 | Ext b Coef 2 | -32768 | 32767 | -605 | Num |
| Data | 104 | 18 | I2 | Ext b Coef 3 | -32768 | 32767 | -2443 | Num |
| Data | 104 | 20 | I2 | Ext b Coef 4 | -32768 | 32767 | 4696 | Num |

Num **Ext a Coef** and **Ext b Coef** are the thermistor temperature linearization polynomial coefficients. The default values were computed with a Semitec 103AT thermistor. If a different type of thermistor is used, then the coefficients will need to be changed. Contact TI to generate coefficients for a different thermistor.

4.9.8 Filter

Defines the filter constant used in \pm *AverageCurrent()* calculation:

$AverageCurrent() = a \times AverageCurrent() \text{ old} + (1-a) \times Current()$ with:

$a = Filter/256$; time constant = $1 \text{ s}/\ln(1/a)$ (default = 14.5 s)

4.9.9 Deadband

Any current within \pm **Deadband** will be reported as 0 mA by the *Current()* function.

4.9.10 CC Deadband

This constant defines the deadband voltage for the measured voltage between the SRP and SRN pins used for capacity accumulation in units of 294 nV. Any voltages within \pm **CC Deadband** do not contribute to capacity accumulation.

4.9.11 SOC Flag Configuration A (SOC Flag Config A) Register

The settings in **SOC Flag Config A** configure how the [TC], [FC], and [TD] flags in *GaugingStatus()* set and clear. These flags are also used to set the [TCA], [TDA], and [FC] flags in *BatteryStatus()*.

Table 4-9. SOCConfiguration Flag A Register Bit Definitions

| | Bit 7 | Bit 6 | Bit 5 | Bit 4 | Bit 3 | Bit 2 | Bit 1 | Bit 0 |
|------------------|-----------------|---------------|----------|--------|-----------------|---------------|----------|--------|
| High Byte | RSVD | RSVD | RSVD | RSVD | TCSETVCT | FCSETVCT | RSVD | RSVD |
| Default | 0 | 0 | 0 | 0 | 1 | 1 | 0 | 0 |
| | 0x0C | | | | | | | |
| Low Byte | TCCLEARR SOC | TCSETR SOC | TCCLEARV | TCSETV | TDCLEARR SOC | TDSETR SOC | TDCLEARV | TDSETV |
| Default | 1 | 0 | 0 | 0 | 1 | 1 | 0 | 0 |
| | 0x8C | | | | | | | |

RSVD = Reserved

TCSETVCT= Enables *BatteryStatus()*[TCA] flag set on primary charge termination

0 = Disabled

1 = Enabled (default)

FCSETVCT= Enables *BatteryStatus()*[FC] flag set on primary charge termination

0 = Disabled

1 = Enabled (default)

TCCLEARRSOC = Enables *BatteryStatus()*[TCA] flag clear when *RelativeStateOfCharge()* \leq **TC:Clear % RSOC Threshold**

0 = Disabled

1 = Enabled (default)

TCSETRSOC = Enables *BatteryStatus()*[TCA] flag set when *RelativeStateOfCharge()* \geq **TC:Set % RSOC Threshold**

0 = Disabled (default)

1 = Enabled

TCCLEARV = Enables *BatteryStatus()*[TCA] flag clear when *Voltage()* \leq **TC:Clear Voltage Threshold**

0 = Disabled (default)

1 = Enabled

TCSETV = Enables *BatteryStatus()*[TCA] flag set when *Voltage()* \geq **TC:Set Voltage Threshold**

0 = Disabled (default)

1 = Enabled

TDCLEARRSOC = Enables *BatteryStatus()*[TDA] flag clear when *RelativeStateOfCharge()* \geq **TD:Clear % RSOC Threshold**

0 = Disabled

1 = Enabled (default)

TDSETRSOC = Enables *BatteryStatus()*[TDA] flag set when *RelativeStateOfCharge()* \leq **TD:Set % RSOC Threshold**

0 = Disabled

1 = Enabled (default)

TDCLEARV = Enables *BatteryStatus()*[TDA] flag clear when *Voltage()* \geq **TD:Clear Voltage Threshold**

0 = Disabled (default)

1 = Enabled

TDSETV = Enables *BatteryStatus()*[TDA] flag set when *Voltage()* \leq **TD:Set Voltage Threshold**

0 = Disabled (default)

1 = Enabled

4.9.12 SOC Flag Configuration B (SOC Flag Config B) Register

Table 4-10. SOCConfiguration Flag B Register Bit Definitions

| | Bit 7 | Bit 6 | Bit 5 | Bit 4 | Bit 3 | Bit 2 | Bit 1 | Bit 0 |
|----------------|-----------------|---------------|----------|--------|----------------|---------------|----------|--------|
| | FCCLEAR RSOC | FCSETRSO C | FCCLEARV | FCSETV | FDCLEAR SOC | FDSETR SOC | FDCLEARV | FDSETV |
| Default | 1 | 0 | 0 | 0 | 1 | 1 | 0 | 0 |
| | 0x8C | | | | | | | |

FCCLEARRSOC = Enables *BatteryStatus()[FC]* flag clear when *RelativeStateOfCharge()* \leq **FC:Clear % RSOC Threshold**
0 = Disabled
1 = Enabled (default)

FCSETRSOC = Enables *BatteryStatus()[FC]* flag set when *RelativeStateOfCharge()* \geq **FC:Set % RSOC Threshold**
0 = Disabled (default)
1 = Enabled

FCCLEARV = Enables *BatteryStatus()[FC]* flag clear when *Voltage()* \leq **FC:Clear Voltage Threshold**
0 = Disabled (default)
1 = Enabled

FCSETV = Enables *BatteryStatus()[FC]* flag set when *Voltage()* \geq **FC:Set Voltage Threshold**
0 = Disabled (default)
1 = Enabled

FDCLEARRSOC = Enables *BatteryStatus()[FD]* flag clear when *RelativeStateOfCharge()* \geq **FD:Clear % RSOC Threshold**
0 = Disabled
1 = Enabled (default)

FDSETRSOC = Enables *BatteryStatus()[FD]* flag set when *RelativeStateOfCharge()* \leq **FD:Set % RSOC Threshold**
0 = Disabled
1 = Enabled (default)

FDCLEARV = Enables *BatteryStatus()[FD]* flag clear when *Voltage()* \geq **FD:Clear Voltage Threshold**
0 = Disabled (default)
1 = Enabled

FDSETV = Enables *BatteryStatus()[FD]* flag set when *Voltage()* \leq **FD:Set Voltage Threshold**
0 = Disabled (default)
1 = Enabled

4.9.13 CEDV Gauging Configuration (CEDV Config) Register

Table 4-11. CEDV Gauging Configuration Register Bit Definitions

| | Bit 7 | Bit 6 | Bit 5 | Bit 4 | Bit 3 | Bit 2 | Bit 1 | Bit 0 |
|------------------|-------|-------|----------------|-------|---------------|----------------|-------|-----------|
| High Byte | RSVD | RSVD | RSVD | SME0 | IGNORE _SD | FC_FOR _VDQ | RSVD | FCC_LIMIT |
| Default | 0 | 0 | 0 | 0 | 0 | 0 | 0 | 0 |
| Low Byte | RSVD | RSVD | FIXED_ EDV0 | SC | EDV_CMP | RSVD | CSYNC | CCT |
| Default | 0 | 0 | 0 | 0 | 0 | 0 | 0 | 0 |

SME0 = Smoothing towards EDV0 enable. Used with SMEN and SMEXT.
0 = Default
1 = Disabled

IGNORE_SD =
0 (default) = Coulomb counter increments during regular or self-discharge.

1 = Coulomb counter increments only if there is a real discharge.

FC_FOR_VDQ =
0 = FC is not required to get VDQ.
1 = FC is required to get VDQ.

FCC_LIMIT = Learned FCC is not allowed to be higher than *DesignCapacity()*. Enabled when set.

FIXED_EDV0 = This bit is used when **[EDV_CMP]** = 1 to determine if EDV0 will use a fixed threshold.
When set to 1, **FIXED_EDV0** will be used.
When set to 0, dynamic EDV0 will be used (default).

SC = This is a selection for learning cycle optimization for a Smart Charger or Independent Charger.
0 = Learning Cycle optimized for Smart Charger (default)
1 = Learning Cycle optimized for Independent Charger

EVD_CMP = Method to calculate EDV compensation
0 = Use fixed EDV values.
1 = Use the EDV compensation to calculate the EDV values.

CSYNC = Sync *RemainingCapacity()* with *FullChargeCapacity()* at valid charge termination
0 = NOT Synchronized (default)
1 = Synchronized

CCT = Cycle Count Threshold
0 = Use CC % of *DesignCapacity()* (default).
1 = Use CC % of *FullChargeCapacity()*.

4.9.14 EMF

This value is the no-load cell voltage higher than the highest cell EDV threshold computed.

4.9.15 C0

This value is the no-load, capacity related EDV adjustment factor.

4.9.16 R0

This value is the first order rate dependency factor, accounting for battery impedance adjustment.

4.9.17 T0

This value adjusts the variation of impedance with battery temperature.

4.9.18 R1

This value adjusts the variation of impedance with battery capacity.

4.9.19 TC

This value adjusts the variation of impedance for cold temperatures ($T < 23^{\circ}\text{C}$).

4.9.20 C1

This value is the desired reserved battery capacity remaining at EDV0.

4.9.21 Age Factor

This value allows the bq27220 device to correct the EDV detection algorithm to compensate for cell aging.

4.9.22 Fixed EDV0

This value is the EDV0 threshold if **[CEDV]** is clear in **CEDV Config**.

4.9.23 **Fixed EDV1**

This value is the EDV1 threshold if **[CEDV]** is clear in **CEDV Config**.

4.9.24 **Fixed EDV2**

This value is the EDV2 threshold if **[CEDV]** is clear in **CEDV Config**.

4.9.25 **Battery Low %**

The value sets should correspond to the capacity value that reflects the highest voltage point.

4.9.26 **Low Temp Learning**

This value specifies the minimum temperature above, which a discharge must maintain to qualify for capacity learning.

4.9.27 **Overload Current**

This value sets the upper current range for EDV detection, beyond which EDV detection is halted.

4.9.28 **Self Discharge Rate**

This value is the estimated self-discharge rate of battery.

4.9.29 **Electronic Load**

This value should be set to a discharge rate determined by the battery electronics current consumption.

4.9.30 **Near Full**

This value sets the start of discharge condition for qualified capacity learning.

4.9.31 **Reserve Capacity**

This value determines how much actual remaining capacity exists when the fuel gauge reports zero for *RemainingCapacity()* before reaching EDV0. This accommodates a controlled shutdown based on battery capacity rather than a specific voltage.

NOTE: If the **Reserve Capacity** is non-zero, then it should be added to the desired **Near Full** capacity as well.

4.9.32 **Charge Efficiency**

This is a value to compensate for efficiency loss during charging when estimating total capacity value. This is based on every coulomb counting charge period and adjusted to reflect the total charge efficiency of the battery pack.

4.9.33 **Discharge Efficiency**

This is a value to compensate for efficiency loss during discharging when estimating total capacity value. This is based on every coulomb counting discharge period and adjusted to reflect the total discharge efficiency of the battery pack.

4.9.34 **Qmax Cell 1 and Qmax Pack**

These are the maximum chemical capacity of the battery pack used when calculating the initial remaining capacity from OCV lookup. For this device both Qmax Cell 1 and Qmax Pack must be set to the same value.

4.9.35 Learned Full Charge Capacity

This value is used to set the *FullChargeCapacity()* after subtracting any **Reserve Capacity** setting. Unlike **Qmax Pack**, this represents the usable capacity from full charge down to EDV0.

4.9.36 DOD at EDV2

This value is updated by the CEDV gauging algorithm when battery voltage reaches EDV2. If **Battery Low %** is altered, the **DOD at EDV2** value should be set to $(1 - \text{Battery_Low\%}) \times 16384$, where $\text{Battery_Low\%} = \text{Battery Low \%} \div 100$. The firmware default value is 15232, which corresponds to a **Battery Low % = 703 (.01 %)**.

4.9.37 Cycle Count

The default value of *CycleCount()* is stored in **Cycle Count** and copied upon bq27220 initialization. When the value changes **Cycle Count** is also updated.

4.9.38 Design Capacity

The *DesignCapacity()* function reports **Design Capacity mAh**.

NOTE: There is only a single **Design Capacity** value for all battery profiles. When setting the battery profile in production, it may be necessary to update **Design Capacity** as well for accurate *StateOfHealth()* results.

4.9.39 Design Voltage

The default value of *DesignVoltage()* is stored in **Design Voltage** and copied upon bq27220 initialization.

4.9.40 Cycle Count %

If the *[CCT]* bit is set the cycle count function counts the accumulated discharge of (*FullChargeCapacity()* × **CC %**) as one cycle. If (*FullChargeCapacity()* × **CC %**) is smaller than **CC Threshold**, **CC Threshold** is used for counting.

4.9.41 Charge Inhibit Temp Low

The bq27220 device does not allow the battery pack to charge if *Temperature()* is below **Charge Inhibit Temp Low**. The *[CHGINH]* bit is set in the *BatteryStatus()*. The default value is 0°C. Charging is allowed once the temperature is above **Charge Inhibit Temp Low** plus **Temp Hys** value. The *[CHGINH]* bit is reset in the *BatteryStatus()* register.

4.9.42 Charge Inhibit Temp High

The bq27220 device does not allow the battery pack to charge if *Temperature()* is above **Charge Inhibit Temp High**. The *[CHGINH]* bit is set in the *BatteryStatus()*. The default value is 45°C. Charging is allowed once the temperature is below **Charge Inhibit Temp High** plus **Temp Hys** value. The *[CHGINH]* bit is reset in the *BatteryStatus()* register.

4.9.43 Temp Hys

The bq27220 device has a temperature hysteresis for both **Charge Inhibit Temp High** and **Charge Inhibit Temp Low** conditions to prevent continuous charger ON/OFF behavior. The default value is 5°C. Charging is allowed once the temperature is below **Charge Inhibit Temp High** plus **Temp Hys** or above **Charge Inhibit Temp Low** plus **Temp Hys** value.

4.9.44 Fast Charge Current

The register sets the fast charging current for the battery pack. This information can be read by the MCU using commands 0x32 and 0x33 *ChargingCurrent()*. This information may be used to communicate the information to a battery charger. This value is set based on battery capacity of the pack and recommended maximum charging current by the cell manufacturers.

4.9.45 Charging Voltage

The bq27220 device sets the maximum cell charging voltage for the pack. This information can be read by the MCU using commands 0x30 and 0x31 *ChargingVoltage()*. This information may be used to communicate the information to a battery charger. This value is set based on battery capacity of the pack and recommended maximum charging voltage by the cell manufacturers.

4.9.46 Taper Current

During Primary Charge Termination detection, one of the three requirements is that the accumulated change in capacity > 0.25 mAh per *Current Taper Window* for the bq27220 device to start trying to qualify a termination. It must be above this Min Taper Capacity before bq27220 starts trying to detect a primary charge termination.

The following conditions qualifies for Primary Charge Termination:

1. During two consecutive periods of *Current Taper Window*, the *Current()* is < *Taper Current*.
2. During the same periods, the accumulated change in capacity > 0.25 mAh per *Current Taper Window*.
3. *Voltage()* > *Charging Voltage* – *Taper Voltage*.

Normal Setting: If the value selected is too high, then it can cause no termination or late termination detection. An example value is 0.25 mAh or C/10 to C/20 based on battery cell characteristics and charger specification. Also two Current Taper qualifications are required to prevent false current taper. False primary termination could occur with pulse charging method and with random starting and resumption of the charge current, a condition that is important at the beginning or end of the qualification period.

4.9.47 Taper Voltage

During Primary Charge Termination detection, one of the three requirements is that **Voltage** must be above (*Charging Voltage* – *Taper Voltage*) for the bq27220 device to start trying to qualify a termination. It must be above this voltage before bq27220 starts trying to detect a primary charge termination.

Normal Setting: This value depends on charger characteristics. It must be set so that ripple voltage, noise, and charger tolerances are taken into account. A high value selected can cause early termination. If the value selected is too low, then it can cause no termination or late termination detection. An example value is 100 mV (see *Taper Current*).

4.9.48 SOC Delta

The percentage value determines when the SOC_INT intervals are registered on the SOC_INT pin. A default value of 1% means the SOC Delta intervals are 0%, 1%, 2%99%, and 100%. A value of 10% would provide SOC_INT pulse at intervals of 0%, 10%, 20%.... 0% and 100%.

4.9.49 Clock Control Register

At reset the hardware Clock Control Register is set to this value. The default setting is 09 hex, which means the XL mode is enabled and the HF oscillator is turned ON after a reset.

4.9.50 Sleep Current

The device is allowed to go into SLEEP mode if the charge or discharge current is below **Sleep Current**. SLEEP mode can be enabled with the **Operation Config A [SLEEP]** bit. If the absolute value of *Current()* is above **Sleep Current**, the bq27220 device will return to NORMAL mode.

4.9.51 Offset Calibration Inhibit Temperature Low

The bq27220 device does not perform auto-calibration on entry to SLEEP mode if *Temperature()* is below **Cal Inhibit Temp Low**. The default is 5°C .

4.9.52 Offset Calibration Inhibit Temperature High

The bq27220 device does not perform auto-calibration on entry to SLEEP mode if *Temperature()* above **Cal Inhibit Temp High**. The default value is 45°C.

4.9.53 Sleep Voltage Time

During SLEEP mode, temperature and voltage measurements will be taken in **Sleep Voltage Time** intervals. The default setting is 20 s.

4.9.54 Sleep Current Time

During SLEEP mode, current will be measured in **Sleep Current Time** intervals. The default value is 20 s.

4.9.55 Dsg Current Threshold

The bq27220 device enters DISCHARGE mode from RELAXATION mode or CHARGE mode if *Current()* < (-) **Dsg Current Threshold**. The default value setting is 60 mA.

4.9.56 Chg Current Threshold

The bq27220 device enters CHARGE mode from RELAXATION mode or DISCHARGE mode if *Current()* > **Chg Current Threshold**. The default value is 75 mA.

4.9.57 Quit Current

The bq27220 device enters RELAXATION mode from CHARGE mode if *Current()* goes below **Quit Current** for **Chg Relax Time**. The device enters RELAXATION mode from DISCHARGE mode if *Current()* goes above (-)**Quit Current** for **Dsg Relax Time**. The default value is 40 mA.

4.9.58 Dsg Relax Time

The bq27220 device enters RELAXATION mode from DISCHARGE mode if *Current()* goes above (-)**Quit Current** for at least **Dsg Relax Time**. The default value is 60 s.

4.9.59 Chg Relax Time

The bq27220 device enters RELAXATION mode from CHARGE mode if *Current()* goes below **Quit Current** for at least **Chg Relax Time**. The default value is 60 s.

4.9.60 Quit Relax Time

The *Quit Relax Time* is the delay time to exit RELAXATION. If current is greater than **Chg Current Threshold** or less than **Dsg Current Threshold** and this condition is maintained for *Quit Relax Time*, then exiting RELAXATION is permitted. This is useful in applications with low duty cycle dynamic loads. The default setting is 1 s.

4.9.61 OT Charge

The bq27220 device sets the [OTC] flag in *BatteryStatus()* if the pack *Temperature()* is equal to or higher than the **Over Temp Chg** threshold. The default value setting is 55°C.

4.9.61.1 OT Charge Time

If the [OTC] condition exists for a time that exceeds the **OT Chg Time** period, the bq27220 device goes into an overtemperature charge condition. This function is disabled if **OT Chg Time** is set to 0.

In an overtemperature charge condition, the *ChargingVoltage()* and *ChargingCurrent()* are set to 0, and the [OTC] bit is set in the *BatteryStatus()* register. The default setting is 2 s.

4.9.62 OT Chg Recovery

The device recovers from an overtemperature charge condition if the *Temperature()* is equal to or lower than the **OT Chg Recovery** level. On recovery, the CHG FET returns to its normal operating state, the *ChargingCurrent()* and *ChargingVoltage()* are set to their appropriate values per the charging algorithm, and the [OTC] flag in *BatteryStatus()* is reset. The default value setting is 50°C.

4.9.63 OT Discharge

The bq27220 device sets the [OTD] flag in *BatteryStatus()* if the pack *Temperature()* is equal to or higher than the **Over Temp Dsg** threshold. The default value setting is 60°C.

4.9.63.1 OT Discharge Time

If the [OTD] condition exists for a time period that exceeds the **OT Dsg Time**, the bq27220 device goes into an overtemperature discharge condition. This function is disabled if **OT Dsg Time** is set to 0.

In an overtemperature discharge condition the *ChargingCurrent()* is set to 0 and the [OTD] bit is set in the *BatteryStatus()* register.

4.9.64 OT Dsg Recovery

The bq27220 device recovers from an overtemperature discharge condition if the *Temperature()* is equal to or lower than the **OT Dsg Recovery** level. On recovery, the DSG FET returns to its normal operating state, the *ChargingCurrent()* and *ChargingVoltage()* are set to their appropriate values per the charging algorithm, and the [OTD] flag in *BatteryStatus()* is reset.

4.9.65 Initial Standby Current

This is the initial value for *StandbyCurrent()*. The default setting is –10 mA.

4.9.66 Default Temperature

This is the temperature used to initialize the *Temperature()* register until the host writes a different value if the **Operation Config A [WRTEMP]** bit is set.

4.9.67 Device Name

The *DeviceName()* function returns a string stored in *DeviceName()*. This is a string data with maximum text length of 7 characters. This field does not affect operation, nor is it used by the device. It is read by using the extended data command: *DeviceName()* (0x63 through 0x69).

4.9.68 System Down Set Voltage

The bq27220 device goes into SYSTEM DOWN mode if the battery pack *Voltage()* is equal to or less than **SysDown Set Voltage Threshold** for **SysDown Set Volt Time**.

4.9.69 System Down Set Voltage Time

The bq27220 device goes into SYSTEM DOWN mode if the battery pack *Voltage()* is equal to or less than **SysDown Set Threshold** for **SysDown Set Time**.

4.9.70 System Down Clear Voltage

The bq27220 device goes into SYSTEM DOWN CLEAR mode if the battery pack *Voltage()* is equal to or above **SysDown Clear Voltage Threshold**.

4.9.71 Full Reset Counter

The counter increments on a full reset event.

4.9.72 Reset Counter Watchdog

The counter increments on a watchdog reset event.

Communications

5.1 I²C Interface

The bq27220 fuel gauge supports the standard I²C read, incremental read, quick read, one byte write, and incremental write functions. The 7-bit device address (ADDR) is the most significant 7 bits of the hex address and is fixed as 1010101. The first 8-bits of the I²C protocol is, therefore, 0xAA or 0xAB for write or read, respectively.

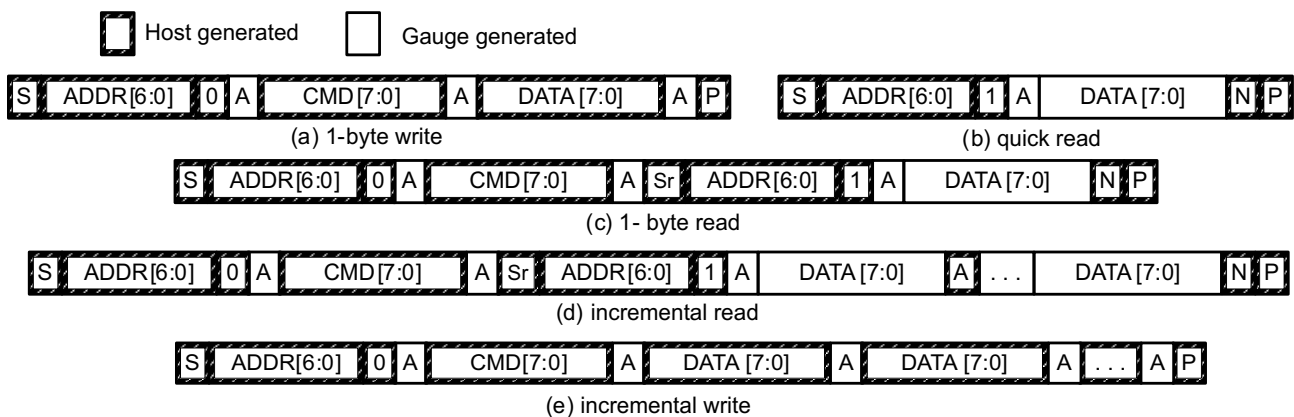

(S = Start, Sr = Repeated Start, A = Acknowledge, N = No Acknowledge, and P = Stop).

The “quick read” returns data at the address indicated by the address pointer. The address pointer, a register internal to the I²C communication engine, increments whenever data is acknowledged by the fuel gauge or the I²C master. “Quick writes” function in the same manner and are a convenient means of sending multiple bytes to consecutive command locations (such as two-byte commands that require two bytes of data).

The following command sequences are not supported:

Attempt to write a read-only address (NACK after data sent by master):

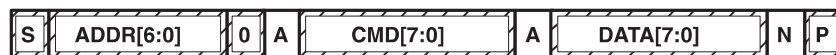

Attempt to read an address above 0x6B (NACK command):



5.2 I²C Time Out

The I²C engine releases both SDA and SCL if the I²C bus is held low for 2 s. If the fuel gauge was holding the lines, releasing them frees them for the master to drive the lines. If an external condition is holding either of the lines low, the I²C engine enters the low-power SLEEP mode.

5.3 I²C Command Waiting Time

To ensure proper operation at 400 kHz, a $t_{(BUF)} \geq 66 \mu s$, bus-free waiting time must be inserted between all packets addressed to the fuel gauge. In addition, if the SCL clock frequency (f_{SCL}) is > 100 kHz, use individual 1-byte write commands for proper data flow control. The following diagram shows the standard waiting time required between issuing the control subcommand the reading the status result. A *DF_CHECKSUM()* subcommand requires 100 ms minimum prior to reading the result. For read-write standard command, a minimum of 2 s is required to get the result updated. For read-only standard commands, there is no waiting time required, but the host should not issue all standard commands more than two times per second. Otherwise, the fuel gauge could result in a reset issue due to the expiration of the watchdog timer.

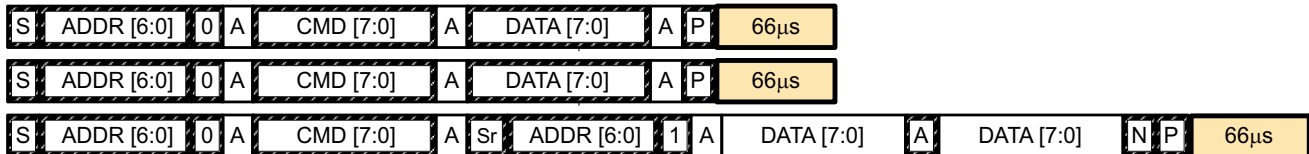

Waiting time inserted between two 1-byte write packets for a subcommand and reading results
(required for $100 \text{ kHz} < f_{SCL} \leq 400 \text{ kHz}$)

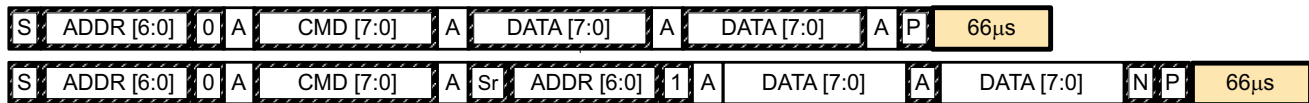

Waiting time inserted between incremental 2-byte write packet for a subcommand and reading results
(acceptable for $f_{SCL} \leq 100 \text{ kHz}$)

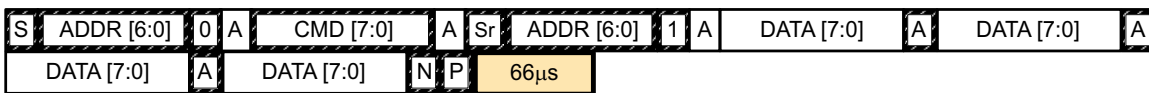

Waiting time inserted after incremental read

5.4 I²C Clock Stretching

A clock stretch can occur during all modes of fuel gauge operation. In SLEEP mode, a short $\leq 100\text{-}\mu s$ clock stretch occurs on all I²C traffic as the device must wake-up to process the packet. In the other modes (INITIALIZATION, NORMAL), a $\leq 4\text{-ms}$ clock stretching period may occur within packets addressed for the fuel gauge as the I²C interface performs normal data flow control.

Application Examples

6.1 Data Memory Parameter Update Example

The following example shows the command sequence needed to modify a Data Memory parameter in RAM. For this example, the default Design Capacity is updated from 3000 mAh to 1200 mAh. All device writes (wr) and reads (rd) refer to the I²C 8-bit addresses 0xAA and 0xAB, respectively.

| Step | Description | Pseudo Code |
|------|--|---|
| 1 | If the device has been previously SEALED, UNSEAL it by sending the appropriate keys to <i>Control()</i> (0x00 and 0x01). | //Two-byte incremental method wr 0x00 0x14 0x04; wr 0x00 0x72 0x36; //Alternative single byte method wr 0x00 0x14; wr 0x01 0x04; wr 0x00 0x72; wr 0x01 0x36; |
| 2 | The bq27220 boots up in UNSEAL, but not in FULL ACCESS. Enter FULL ACCESS to gain access to the Data Memory. | //Two-byte incremental method wr 0x00 0xFF 0xFF; wr 0x00 0xFF 0xFF; //Alternative single byte method wr 0x00 0xFF; wr 0x01 0xFF; wr 0x00 0xFF; wr 0x01 0xFF; |
| 3 | Send ENTER_CFG_UPDATE command (0x0090). | wr 0x00 0x90 0x00; |
| 4 | Confirm CFGUPDATE mode by polling <i>OperationStatus()</i> register until bit 2 is set. May take up to 1 second. | rd 0x3B OperationStatus(); |
| 5 | Write 0x9F to 0x3E to access the MSB of Design Capacity . | wr 0x3E 0X9F; |
| 6 | Write 0x92 to 0x3F to access the LSB of Design Capacity . | wr 0x3F 0X92; |
| 7 | Read the 1-byte checksum using <i>MACDataSum()</i> command (0x60). | rd 0x60 Old_Chksum; |
| 8 | Read the 1-byte block length using the <i>MACDataLen()</i> command (0x61). | rd 0x61 Data_len; |
| 9 | Read both Design Capacity bytes starting at 0x40. | rd 0x40 Old_DC_MSB; rd 0x41 Old_DC_LSB; |
| 10 | Write both Design Capacity bytes starting at 0x40. For this example, the new value is 1200 mAh. (0x04B0 in hex) | wr 0x40 0x04; wr 0X41 0XB0; |
| 11 | Calculate the new checksum. The checksum is (255 – x) where x is the 8-bit summation of the <i>BlockData()</i> (0x40 to 0x5F) on a byte-by-byte basis. A quick way to calculate the new checksum uses a data replacement method with the old and new data summation bytes. Refer to the code for the indicated method. | Temp = mod(255 – Old_Chksum – OLD_DC_MSB – OLD_DC_LSB, 256); New_Chksum = 255 – mod(temp + 0x04 + 0Xb0, 256); |
| 12 | Write new checksum. For this example, New_Chksum is 0XB0; | wr 0x60 New_Chksum; //Example: wr 0x60 0XB0; |
| 13 | Write the block length. The data is actually transferred to the RAM when the correct checksum and length for the whole block is written. For this example, Data_len is 0x24; | wr 0x61 Data_len; //Example: wr 0x61 0X24; |
| 14 | Exit CFGUPDATE mode by sending either EXIT_CFG_UPDATE_REINIT (0x0091) or EXIT_CFG_UPDATE (0x0092) commands. | wr 0x00 0x91 0x00; or wr 0x00 0x92 0x00; |
| 15 | Confirm CFGUPDATE mode by polling <i>OperationStatus()</i> register until bit 2 is clear. May take up to 1 second. | rd 0x3B OperationStatus(); |
| 16 | If the device was previously SEALED, return to SEALED mode by sending the Control (0x0030) subcommand. | wr 0x00 0x30 0x00; |

Open-Circuit Voltage Measurement Background

The accuracy of the CEDV algorithm strongly depends on the accuracy and validity of the open-circuit voltage (OCV) measurement taken by fuel gauges that are based on CEDV technology. This appendix describes the process of taking OCV measurements during different events.

A.1 Background

- **OCV Calculation:** OCV (open-circuit voltage) is normally a calculated value because a true measurement of OCV requires an unloaded and relaxed condition on the battery. Because such an unloaded and completely relaxed condition is not always possible in a real system, the fuel gauge uses measured voltage, current, and temperature (VIT) to compute the OCV and as a result of this calculation, the state of charge (SOC) of the battery is established or reestablished.
- **OCV Qualification Time (QT):** The time in which SOC_INT is asserted during an OCV measurement is approximately 165 ms. This is the timeframe in which we test if the VIT measurement is qualified for an OCV calculation. This is not the timeframe in which the actual VIT measurement is taken. During this time, the instantaneous current (adci) is measured. If $\text{abs}(\text{adci}) \geq \text{DesignCapacity}/18$, then the `[OCVFail]` bit is set. Otherwise, the VIT just measured is qualified and the gauge proceeds with OCV calculation.
- **Current Measurement Time (CMT):** The time of current is measured – 1 s.
- **Voltage Measurement Time (VMT):** The time of voltage is measured – 125 ms.
- **Temperature Measurement Time (TMT):** The time of temperature is measured – 125 ms.

A.1.1 OCV Qualification and Calculation

OCV qualification and calculation (**QC**) happens under two conditions:

- OCV_CMD is sent by the host.
- Battery Insert (**BI**) event is detected.

NOTE: POR causes an immediate BI.

A.1.2 OCV Calculation Assumption

The current, voltage, and temperature must remain stable during QT, CMT, VMT, and TMT. In every case that stable VIT is mentioned, the desired stable condition for current is $< C/20$. If this is not true, errors can be introduced into the OCV Calculation.

A.1.3 OCV Timing

The timing of each step in the OCV sequence is shown in [Figure A-1](#).

1. After a POR, voltage, current, and temperature are measured before updating the fuel gauge parameters.
2. Quick voltage and current measurements are taken to qualify OCV VIT conditions.
3. Voltage, current, and temperature are measured for subsequent fuel gauge parameters updates.

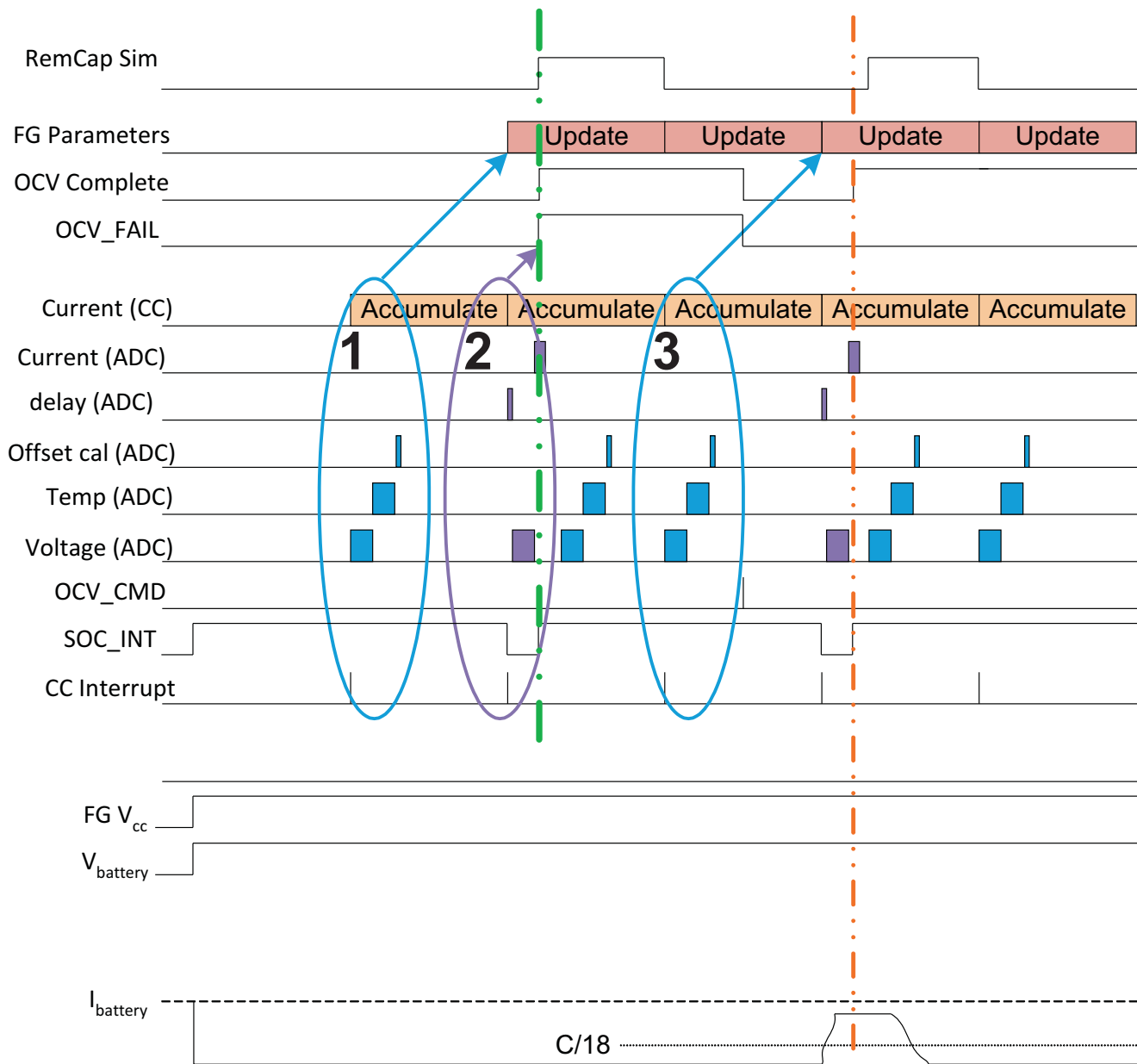

Figure A-1. OCV Timing Sequences

The green dashed lines indicate the completion of an OCV measurement that has failed due to the high load detected in current (ADC) measurement; whereas, the orange dashed lines indicate the completion of a successful OCV measurement, given that the load at the time of measurement was below C/18 rate.

The second OCV measurement (orange line) is a success by qualification standard. However, this is not the recommended-use case because the current is only lowered during the OCV_INT time (the qualification time). This makes the fuel gauge respond as if this were a pass condition; however, the actual result is not good because the actual VIT measurement used for OCV was taken under high load.

A.2 OCV Timing and OCV_CMD Use Recommendations

A.2.1 ACTIVE Mode (Fuel Gauge Is Not in SLEEP Mode)

The VIT measurement used for the OCV calculation is the last VIT measured before the OCV_CMD was received. The VIT value used for the OCV calculation needs to be a stable, not transient value. Before sending the OCV_CMD, the current must be stable and $< C/20$ for at least one second. The recommendations for the OCV_CMD used for ACTIVE mode is that the VIT remains stable from two seconds before the OCV_CMD is sent until the end of SOC_INT (see [Figure A-2](#)).

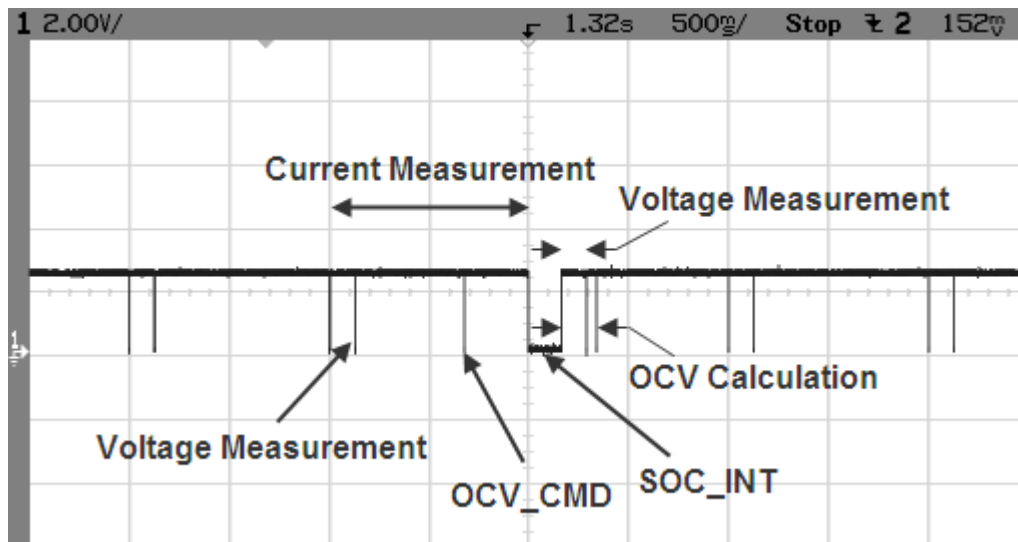

Figure A-2. OCV Calculation Based on OCV Command

A.2.2 SLEEP Mode

In SLEEP mode, the fuel gauge measures VIT every 20 s, instead of 1 s. The VIT measurement used for the OCV calculation is the last VIT measured before the OCV_CMD was received. Sleep current is usually below the OCV current-fail threshold. So, the recommendations for the OCV_CMD sent during SLEEP mode is that the VIT remains stable and below the sleep threshold from the time OCV_CMD is sent until the end of SOC_INT.

A.2.3 Initial OCV – POR

During POR, the VIT measurement used for the OCV calculation and qualification takes place between about 300 ms after POR until the end of SOC_INT. To achieve a good initial OCV measurement after POR, the recommendation is to keep VIT stable from POR until the end of SOC_INT (see [Figure A-3](#)).

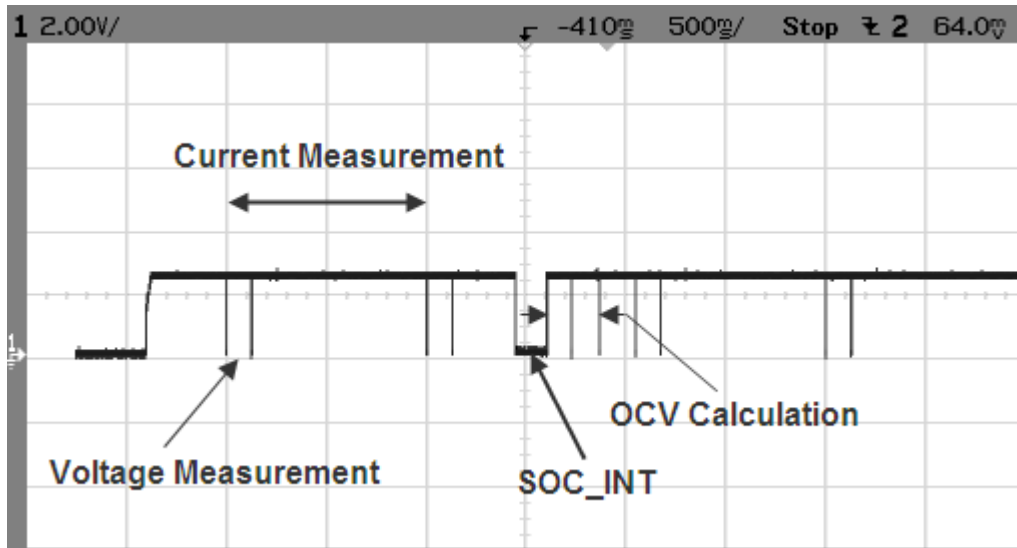

Figure A-3. Initial OCV Taken After POR

Updating bq27220 Configuration Parameters

There are two ways the user can program custom configurations/profiles into the bq27220 device:

1. Download the configuration/profile to bq27220 RAM on power up.

The bq27220 fuel gauge has RAM-based data memory parameters that can be updated if needed by the host processor. This prevents external communication access to the fuel gauge to allow updating with external tools. It may be useful that the application system main processor perform the actual firmware updating, rather than having an external tool do it. The [Battery Management Studio \(bqStudio\)](#) software can export gauge mode FlashStream (gm.fs) files that can be used by the host to program the profiles in the device RAM.

2. Download the configuration/profile to bq27220 OTP.

On subsequent power cycles, the device uses the programmed profile for gauging. This appendix describes the process of generating ot.fs files from bqStudio and using the SmartFlash tool to program the OTP with the generated ot.fs file.

B.1 Gauge Mode FlashStream (gm.fs) Files

With the [Battery Management Studio \(bqStudio\)](#) software, the user can generate specific instruction files called gm.fs files, which contain the necessary I²C commands that a host can send to the bq27220 device to program the RAM-based data memory parameters. The commands in these files are largely ROM commands that can be used only when the gauge is in CONFIG_UPDATE mode.

The gm.fs file is an ASCII text file that contains commands and data. Each line of the file represents one command and potentially 96 bytes of data, as described in the following text. No row contains more than 96 data bytes. The first two characters of each row represent the command, followed by a ":

"W:" — Indicates that the row is a command to write one or more bytes of data.

"C:" — Indicates that the row is a command to read and compare one or more bytes of data.

"X:" — Indicates that the row is a command to wait a given number of milliseconds before proceeding.

White space is used to separate fields within the gm.fs files. Each row contains *only one* of the four commands. The commands discussed in this section can be implemented by a system that can perform multi-byte or single-byte operations for I²C.

Figure B-1 shows a typical gm.fs file snippet generated from the bqStudio software.

```

1  ;-----
2  ;Verify Existing Firmware Version
3  ;-----
4  W: AA 00 01 00
5  C: AA 00 21 06
6  W: AA 00 02 00
7  C: AA 00 05 01
8  ;-----
9  ;SET_CFGUPDATE
10 ;-----
11 W: AA 00 13 00
12 X: 1500
13 W: AA 3E 02 00
14 W: AA 40 02 26 00 00 32 00 00 00 00 00 00 00 00 00 00 00 00 00 00 00 00 00 00 00 00 00 00 00
15 W: AA 60 A5
16 X: 200
17 W: AA 3E 02 00
18 C: AA 60 A5
19 W: AA 3E 24 00
20 W: AA 40 00 19 28 63 5F FF 62 00 32 00 00 00 00 00 00 00 00 00 00 00 00 00 00 00 00 00 00 00 00
21 W: AA 60 69
22 X: 200
23 W: AA 3E 24 00
24 C: AA 60 69
25 W: AA 3E 30 00
26 W: AA 40 0E 10 FD FF 38 00 00 00 00 00 00 00 00 00 00 00 00 00 00 00 00 00 00 00 00 00 00 00
27 W: AA 60 AD
28 X: 200
29 W: AA 3E 30 00
30 C: AA 60 AD
31 W: AA 3E 31 00
32 W: AA 40 0A 0F 02 05 32 00 00 00 00 00 00 00 00 00 00 00 00 00 00 00 00 00 00 00 00 00 00 00
33 W: AA 60 AD

```

Normal text file | length: 5015 | lines: 181 | Ln: 112 | Col: 6 | Sel: 0 | 0 | UNIX | ANSI as UTF-8 | INS

Figure B-1. Typical gm.fs File Snippet

B.1.1 Write Command

The write command "W:" instructs the I²C master to write one or more bytes to a given I²C address and given register address. The I²C address format used throughout this document is based on an 8-bit representation of the address. The format of this sequence is:

"W: I2CAddr RegAddr Byte0 Byte1 Byte2..."

For example, the following:

W: AA 55 AB CD EF 00

Indicates that the I²C master writes the byte sequence 0xAB 0xCD 0xEF 0x00 to register 0x55 of the device addressed at 0xAA.

More precisely, it indicates to write the following data to the device address 0xAA:

- 0xAB to register 0x55
- 0xCD to register 0x56
- 0xEF to register 0x57
- 0x00 to register 0x58

B.1.2 Read and Compare Command

The read and compare command is formatted identically to the write command. The data presented with this command matches the data read exactly, or the operation should cease with an error indication to the user. The gm.fs file contains no information about program flow or decision making. If a read and compare command results in data which does not match the expected values then the interpreting program needs to handle the next step itself. It should not continue with further commands, but would typically go back to the beginning of the gm.fs file and try again several times before giving up.

The format of this sequence is:

```
"C: i2cAddr RegAddr Byte0 Byte1 Byte2"
```

An example of this command is as follows:

```
C: AA 55 AB CD EF 00
```

This example expects the master to read back 4 bytes from the register address 0x55 of the device addressed at 0xAA and then compare the data to the values given on the line command in this same order as 0xAB, 0xCD, 0xEF, and 0x00.

B.1.3 Wait Command

The wait command indicates that the host waits a minimum of the given number of milliseconds before continuing to the next row of the FlashStream file. A wait command is typically used to allow the fuel gauge processor to complete a process before proceeding to the next command in the file.

For example, the following:

```
X: 200
```

Indicates that the I²C master must wait at least 200 ms before continuing.

B.1.4 CONFIG UPDATE Mode

If the application requires different configuration data for the fuel gauge, the system processor can update RAM-based data memory parameters using the *Control()SET_CFGUPDATE* subcommand to enter the CONFIG UPDATE mode.

NOTE: To ensure that the fuel gauge has entered CONFIG UPDATE mode correctly, there needs to be at least an 1100-ms delay after sending the *SET_CFGUPDATE*. Operation in this mode is indicated by the *Flags()[CFGUPMODE]* status bit.

In this mode, fuel gauging is suspended while the host uses the extended data commands to modify the configuration data blocks. To resume fuel gauging, the host must send a *Control()SOFT_RESET* subcommand to exit the CONFIG UPDATE mode, which clears both *Flags()[ITPOR]* and *[CFGUPMODE]* bits. After a timeout of approximately 240 seconds (4 minutes), the gauge automatically exits the CONFIG UPDATE mode if it has not received a *SOFT_RESET* subcommand from the host.

The memory of the bq27220 device is separated into memory subclasses defined in this document. The memory cannot be directly addressed, but is updated through a sequence of extended commands that can access each block of memory indirectly. The gm.fs file updates these blocks to write the proper configuration so the bq27220 device can have proper gauging performance and match the system characteristics. These updates are stored in RAM and need to be re-programmed any time the device loses power. (The *[ITPOR]* bit in the *Flags()* register indicates that the RAM configuration has been reset to the defaults, and is in need of updating using the gm.fs file.)

B.2 OTP Mode FlashStream (ot.fs) Files

With the [Battery Management Studio \(bqStudio\)](#) software, the user can generate specific instruction files called ot.fs files, which contain the necessary I²C commands that a host can send to the bq27220 device to program the RAM-based data memory parameters. The commands in these files are largely ROM commands that can be used only when the gauge is in CONFIG_UPDATE mode.

The ot.fs file is an ASCII text file that contains commands and data. Each line of the file represents one command and potentially 96 bytes of data, as described in the following text. No row contains more than 96 data bytes. The first two characters of each row represent the command, followed by a ":

- "W:" — Indicates that the row is a command to write one or more bytes of data.
- "C:" — Indicates that the row is a command to read and compare one or more bytes of data.
- "X:" — Indicates that the row is a command to wait a given number of milliseconds before proceeding.

White space is used to separate fields within the ot.fs files. Each row contains *only one* of the four commands. The commands discussed in this section can be implemented by a system that can perform multi-byte or single-byte operations for I²C.

Figure B-1 shows a typical ot.fs file snippet generated from the bqStudio software.

```

1 ;-----
2 ;Verify Existing Firmware Version
3 ;-----
4 W: AA 00 01 00
5 C: AA 00 21 06
6 W: AA 00 02 00
7 C: AA 00 05 01
8 ;-----
9 ;SET_CFGUPDATE
10 ;-----
11 W: AA 00 13 00
12 X: 1500
13 W: AA 3E 02 00
14 W: AA 40 02 26 00 00 32 00 00 00 00 00 00 00 00 00 00 00 00 00 00 00 00 00 00 00 00 00 00 00 00 00 00
15 W: AA 60 A5
16 X: 200
17 W: AA 3E 02 00
18 C: AA 60 A5
19 W: AA 3E 24 00
20 W: AA 40 00 19 28 63 5F FF 62 00 32 00 00 00 00 00 00 00 00 00 00 00 00 00 00 00 00 00 00 00 00 00 00 00 00 00
21 W: AA 60 69
22 X: 200
23 W: AA 3E 24 00
24 C: AA 60 69
25 W: AA 3E 30 00
26 W: AA 40 0E 10 FD FF 38 00 00 00 00 00 00 00 00 00 00 00 00 00 00 00 00 00 00 00 00 00 00 00 00 00 00 00 00 00
27 W: AA 60 AD
28 X: 200
29 W: AA 3E 30 00
30 C: AA 60 AD
31 W: AA 3E 31 00
32 W: AA 40 0A 0F 02 05 32 00 00 00 00 00 00 00 00 00 00 00 00 00 00 00 00 00 00 00 00 00 00 00 00 00 00 00 00 00
33 W: AA 60 AD
  
```

Figure B-2. Typical ot.fs File Snippet

B.2.1 Write Command

The write command "W:" instructs the I²C master to write one or more bytes to a given I²C address and given register address. The I²C address format used throughout this document is based on an 8-bit representation of the address. The format of this sequence is:

"W: I2CAddr RegAddr Byte0 Byte1 Byte2..."

For example, the following:

W: AA 55 AB CD EF 00

Indicates that the I²C master writes the byte sequence 0xAB 0xCD 0xEF 0x00 to register 0x55 of the device addressed at 0xAA.

More precisely, it indicates to write the following data to the device address 0xAA:

0xAB to register 0x55

0xCD to register 0x56

0xEF to register 0x57

0x00 to register 0x58

B.2.2 Read and Compare Command

The read and compare command is formatted identically to the write command. The data presented with this command matches the data read exactly, or the operation should cease with an error indication to the user. The ot.fs file contains no information about program flow or decision making. If a read and compare command results in data which does not match the expected values then the interpreting program needs to handle the next step itself. It should not continue with further commands, but would typically go back to the beginning of the ot.fs file and try again several times before giving up.

The format of this sequence is:

```
"C: i2cAddr RegAddr Byte0 Byte1 Byte2"
```

An example of this command is as follows:

```
C: AA 55 AB CD EF 00
```

This example expects the master to read back 4 bytes from the register address 0x55 of the device addressed at 0xAA and then compare the data to the values given on the line command in this same order as 0xAB, 0xCD, 0xEF, and 0x00.

B.2.3 Wait Command

The wait command indicates that the host waits a minimum of the given number of milliseconds before continuing to the next row of the FlashStream file. A wait command is typically used to allow the fuel gauge processor to complete a process before proceeding to the next command in the file.

For example, the following:

```
X: 200
```

Indicates that the I²C master must wait at least 200 ms before continuing.

B.2.4 CONFIG UPDATE Mode

If the application requires different configuration data for the fuel gauge, the system processor can update RAM-based data memory parameters using the *Control()SET_CFGUPDATE* subcommand to enter the CONFIG UPDATE mode.

NOTE: To ensure that the fuel gauge has entered CONFIG UPDATE mode correctly, there needs to be at least an 1100-ms delay after sending the *SET_CFGUPDATE*. Operation in this mode is indicated by the *Flags()[CFGUPMODE]* status bit.

In this mode, fuel gauging is suspended while the host uses the extended data commands to modify the configuration data blocks. To resume fuel gauging, the host must send a *Control()SOFT_RESET* subcommand to exit the CONFIG UPDATE mode, which clears both *Flags()[ITPOR]* and *[CFGUPMODE]* bits. After a timeout of approximately 240 seconds (4 minutes), the gauge automatically exits the CONFIG UPDATE mode if it has not received a *SOFT_RESET* subcommand from the host.

The memory of the bq27220 device is separated into memory subclasses defined in this document. The memory cannot be directly addressed, but is updated through a sequence of extended commands that can access each block of memory indirectly. The ot.fs file updates these blocks to write the proper configuration so the bq27220 device can have proper gauging performance and match the system characteristics. These updates are stored in RAM and need to be re-programmed any time the device loses power. (The *[ITPOR]* bit in the *Flags()* register indicates that the RAM configuration has been reset to the defaults, and is in need of updating using the ot.fs file.)

B.3 Programming Instructions

B.3.1 Using gm.fs Files

To use gm.fs files to configure the bq27220 device on power up, do the following:

Step 1: Use the [GPCCEDV tool](#) (on [ti.com](#)) to generate the 7-point CEDV parameter and the 11-point loaded voltage points. Refer to the *bq27220EVM-744 User's Guide* ([SLUUBF5](#)).

Step 2: Use the [Battery Management Studio \(bqStudio\)](#) software (the fuel gauge evaluation software) to finalize all the values for Calibration/Configuration/Gas Gauging in RAM based on the application.

Step 3: Use bqStudio to generate a gm.fs file, which contains I²C instructions (with data) to write all the parameters (from Step 2) by the host on power up.

Step 4: Use the gm.fs to program the bq27220 RAM every time on a power up.

The host programs the configuration/profile into one of the three available OTP areas.

The bq27220 fuel gauge has two One-Time Programmable (OTP) areas for custom CEDV profile programming. In cases where the user does not want to program the RAM in the bq27220 device every time on a power up, there is a provision to program the custom CEDV profiles in the OTP area of the bq27220 device. Once programmed, the fuel gauge automatically uses the OTP profile the next time the gauge is powered up.

The bq27220 device has two sections of the OTP that are available for the user:

1. Configuration Area: Customers can update this one time, based on the application.
2. Profile Area: Three empty profile areas (Profile1/2/3) are provided, which customers can use to program custom profile information.

B.3.2 Using ot.fs Files

To use ot.fs files to configure the bq27220 device on power up, do the following:

Step 1: Use the [GPCCEDV tool](#) (on [ti.com](#)) to generate the 7-point CEDV parameter and the 11-point loaded voltage points. Refer to the *bq27220EVM-744 User's Guide* ([SLUUBF5](#)).

Step 2: Use the [Battery Management Studio \(bqStudio\)](#) software to finalize all the values for Calibration/Configuration/Gas Gauging in RAM based on the application.

Step 3:

Programming the OTP Profile 1:

- (a) Fill out the CEDV Profile 1 section in RAM with required values.
- (b) Write CEDV Profile Select → Battery ID to 4.

Programming the OTP Profile 2:

- (a) Fill out the CEDV Profile 1 section in RAM with required values.
- (b) Write CEDV Profile Select → Battery ID to 8.

Programming the OTP Profile 3:

- (a) Fill out the CEDV Profile 1 section in RAM with required values.
- (b) Write CEDV Profile Select → Battery ID to 16.

Step 4: Use bqStudio to generate the ot.fs file, which contains I²C instructions (with data) on how to program the OTP with the values that were just setup in RAM.

Step 5: Use the ot.fs file with the SmartFlash programming tool; the OTP on the bq27220 device can be programmed.

B.4 General Setup and Software Installation to Program OTP

1. Equipment needed:

- (a) Lab power supply configured for 7.4-V output (expect ~5-mA maximum current)

- (b) Battery or second power supply with $\geq 3.0\text{-V}$ output (expect $\sim 1\text{-mA}$ maximum current)
 - (c) EV2300 (v3.1r or later) or EV2400 USB with I²C interface adapter
 - (d) Un-programmed bq27220 device assembled in the battery pack or on the EVM
 - (e) Example .gg file provided by factory
 - (f) [Battery Management Studio \(bqStudio\)](#) software installer
 - (g) SmartFlash software executable
2. Install the [bqStudio](#) software.
 3. Connect the EV2300 or EV2400 to the unprogrammed device or EVM.
 4. Connect the battery to BAT(+) and V_{SS}(-) pins.
 5. With output disabled, connect the lab power supply to GPOUT and V_{SS}(-) pins.

NOTE: Do not apply 7.4 V to the device until prompted by software.

B.5 Launch bqStudio Software

1. Launch bqStudio software.
2. Confirm *Gauge Dashboard* panel detects the EV2x00 adapter and the bq27220 device.
3. If the device has been previously SEALED, UNSEAL it by sending the appropriate keys to *Control()* (0x00 and 0x01). The bq27220 boots up in UNSEAL mode, but not in FULL ACCESS mode. Enter FULL ACCESS mode to gain access to the Data Memory. See [Chapter 6](#) for the procedure to enter FULL ACCESS.
4. Click **Data Memory** to show the OTP factory defaults that are in data memory (RAM).
5. Click **Import** to load **Data Memory** contents from provided sample .gg file.

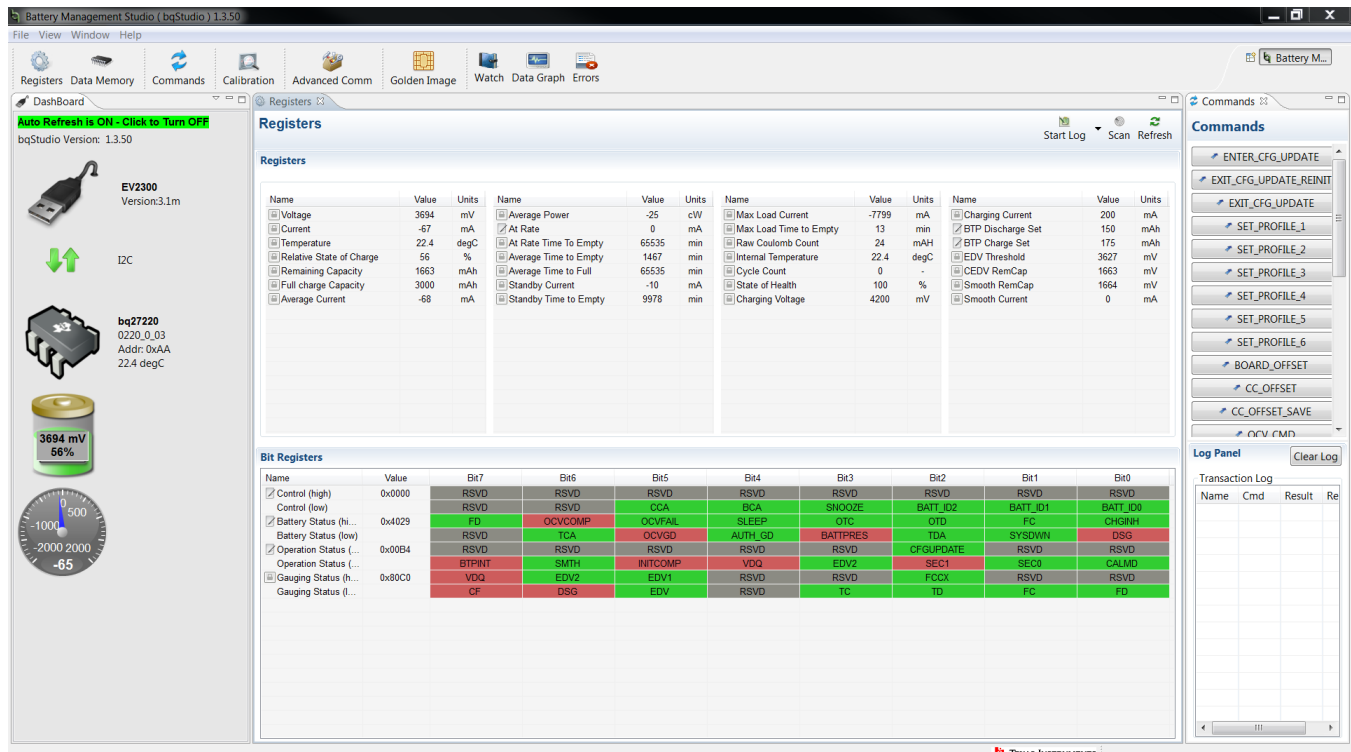

Figure B-3. Launch bqStudio Software

B.6 Load .GG File

This procedure imports the fuel gauge data or the data memory image to the device.

1. Browse to a desired template or sample *.GG parameter file. (Example: bq27220.gg.csv in [Figure B-4.](#))
2. Click **Open** button.

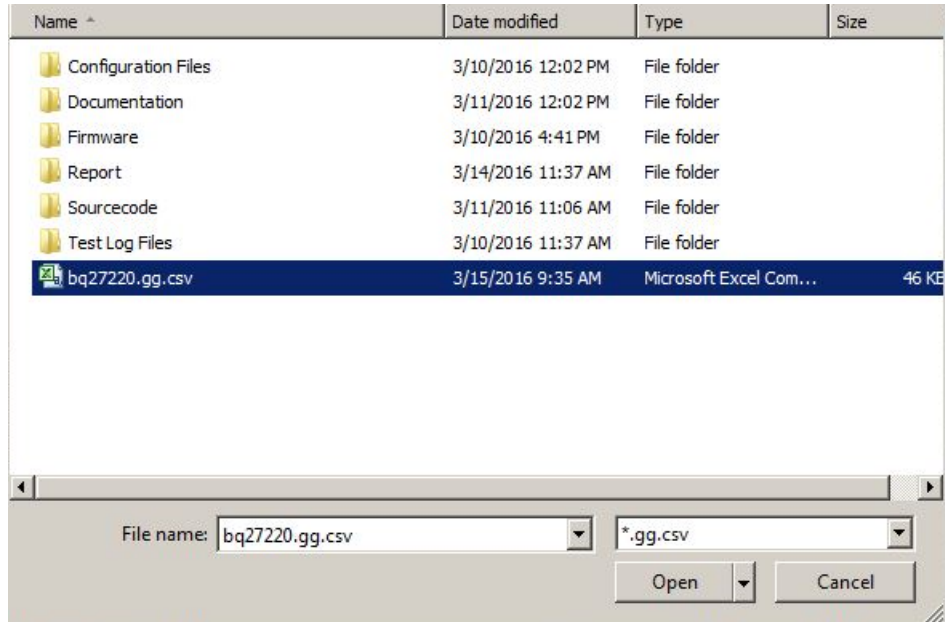

Figure B-4. Load .GG File

B.7 Confirm or Update Data Memory Parameters

1. Imported Data Memory (RAM) parameters that differ from the factory defaults will appear in orange font.
2. Confirm or update Data Memory (RAM) parameters as required.
3. Save .GG file for future reference by clicking **Export**.

Data Memory

Read/Write Data Memory Contents

| | Name | Private | Value | Unit | Physical S... | Data Length | Row Num... | Row Offset | Native Units |
|-----------------------------|----------------------------|---------|-------|------|---------------|-------------|------------|------------|--------------|
| Calibration | Full Charge Capacity | | 3000 | mAh | 0x929d | 2 | 660 | 29 | mAh |
| Configuration | Design Capacity | | 3000 | mAh | 0x929f | 2 | 660 | 31 | mAh |
| Gas Gauging | Design Voltage | | 3700 | mV | 0x92a3 | 2 | 661 | 3 | mV |
| Calibration (Present OTP) | Charge Termination Voltage | | 109 | mV | 0x92a5 | 2 | 661 | 5 | mV |
| Configuration (Present OTP) | EMF | | 3743 | - | 0x92a7 | 2 | 661 | 7 | - |
| Gas Gauging (Present OTP) | C0 | | 149 | - | 0x92a9 | 2 | 661 | 9 | - |
| Calibration (ROM Default) | R0 | | 667 | - | 0x92ab | 2 | 661 | 11 | - |
| Configuration (ROM Default) | T0 | | 4030 | - | 0x92ad | 2 | 661 | 13 | - |
| Gas Gauging (ROM Default) | R1 | | 316 | - | 0x92af | 2 | 661 | 15 | - |
| | TC | | 9 | - | 0x92b1 | 1 | 661 | 17 | - |
| | C1 | | 0 | - | 0x92b2 | 1 | 661 | 18 | - |
| | Age Factor | | 0 | - | 0x92b3 | 1 | 661 | 19 | - |
| | Fixed EDV 0 | | 3031 | mV | 0x92b4 | 2 | 661 | 20 | mV |
| | EDV 0 Hold Time | | 1 | s | 0x92b6 | 1 | 661 | 22 | s |
| | Fixed EDV 1 | | 3385 | mV | 0x92b7 | 2 | 661 | 23 | mV |
| | EDV 1 Hold Time | | 1 | s | 0x92b9 | 1 | 661 | 25 | s |
| | Fixed EDV 2 | | 3591 | mV | 0x92ba | 2 | 661 | 26 | mV |
| | EDV 2 Hold Time | | 1 | s | 0x92bc | 1 | 661 | 28 | s |
| | Voltage 0% DOD | | 4173 | mV | 0x92bd | 2 | 661 | 29 | mV |
| | Voltage 10% DOD | | 4043 | mV | 0x92bf | 2 | 661 | 31 | mV |
| | Voltage 20% DOD | | 3925 | mV | 0x92c1 | 2 | 662 | 1 | mV |
| | Voltage 30% DOD | | 3821 | mV | 0x92c3 | 2 | 662 | 3 | mV |
| | Voltage 40% DOD | | 3725 | mV | 0x92c5 | 2 | 662 | 5 | mV |
| | Voltage 50% DOD | | 3656 | mV | 0x92c7 | 2 | 662 | 7 | mV |
| | Voltage 60% DOD | | 3619 | mV | 0x92c9 | 2 | 662 | 9 | mV |
| | Voltage 70% DOD | | 3582 | mV | 0x92cb | 2 | 662 | 11 | mV |
| | Voltage 80% DOD | | 3515 | mV | 0x92cd | 2 | 662 | 13 | mV |
| | Voltage 90% DOD | | 3439 | mV | 0x92cf | 2 | 662 | 15 | mV |
| | Voltage 100% DOD | | 2713 | mV | 0x92d1 | 2 | 662 | 17 | mV |

Figure B-5. Confirm or Update Data Memory Parameters

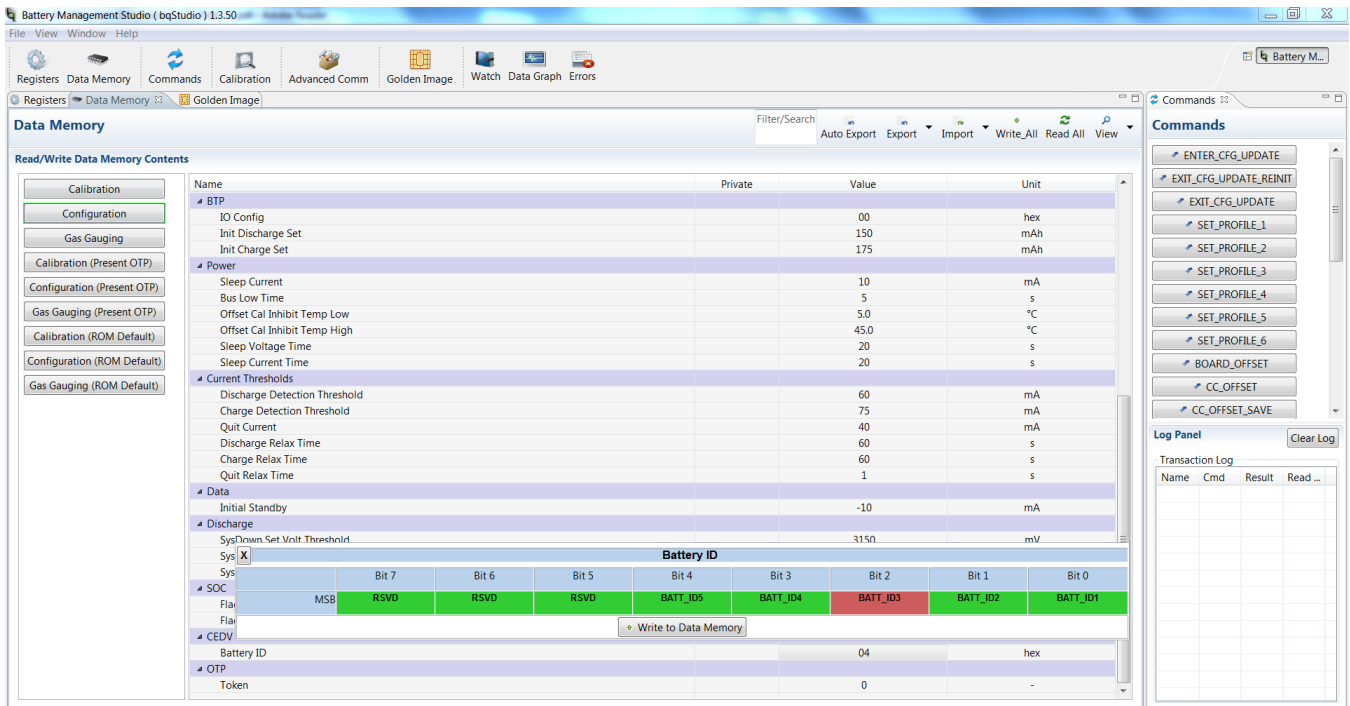

Figure B-6. Update Battery ID

4. Set BATT_ID2 to 1.

B.8 Save .OTFS File

1. Click **GoldenImage** icon.
2. From **GoldenImage** panel, enter desired .OTFS base file name (example, bq27220.ot.fs).

NOTE: No **Options** changes are required.

3. Click **Create Image File**.
4. Exit bqStudio software.

NOTE: Important because the EV2x00 adapter must be freed for SmartFlash.

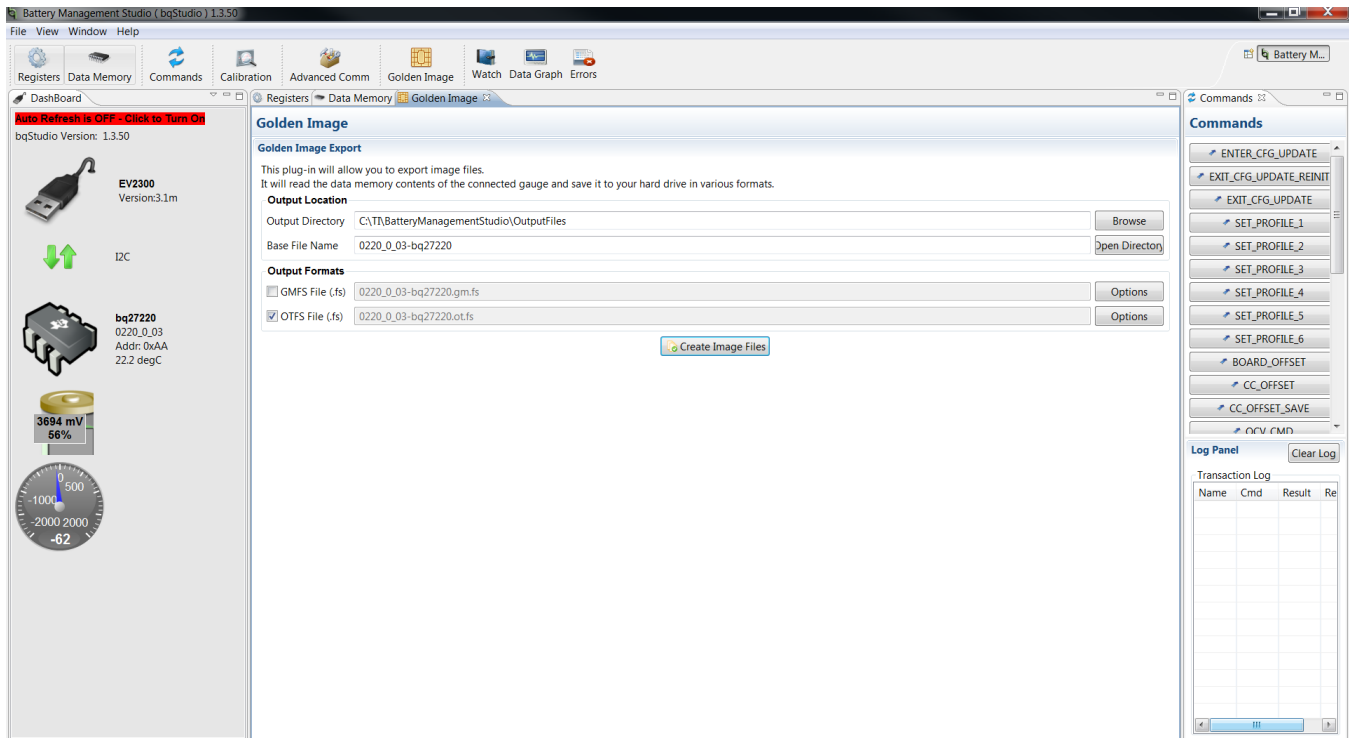

Figure B-7. Save .OTFS File

B.9 Launch SmartFlash Software

1. Launch SmartFlash software.
2. Confirm auto-detection of the EV2x00 adapter, Gauge = 220 and Version \geq 1.09.
3. Click **File > Open**.

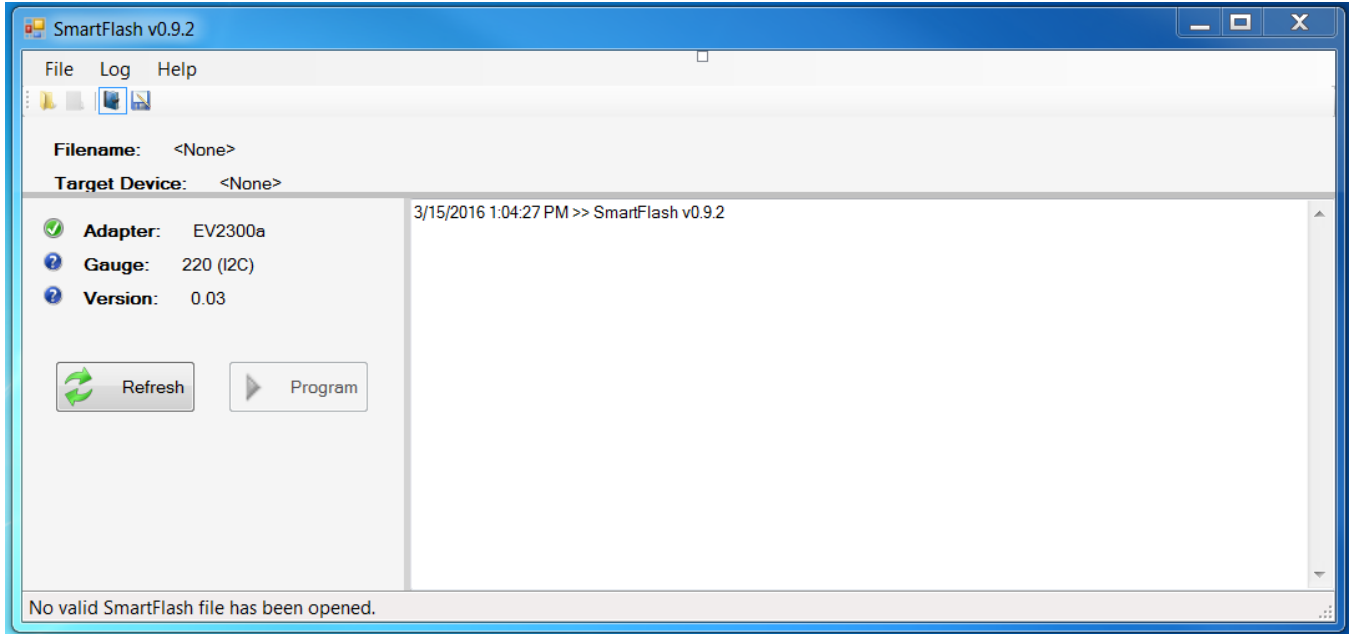

Figure B-8. Launch SmartFlash Software

B.10 Open Ot.fs File

1. From the pop-up dialog box, click the needed ot.fs file and click **Open**.
2. Confirm successful file load from log window.

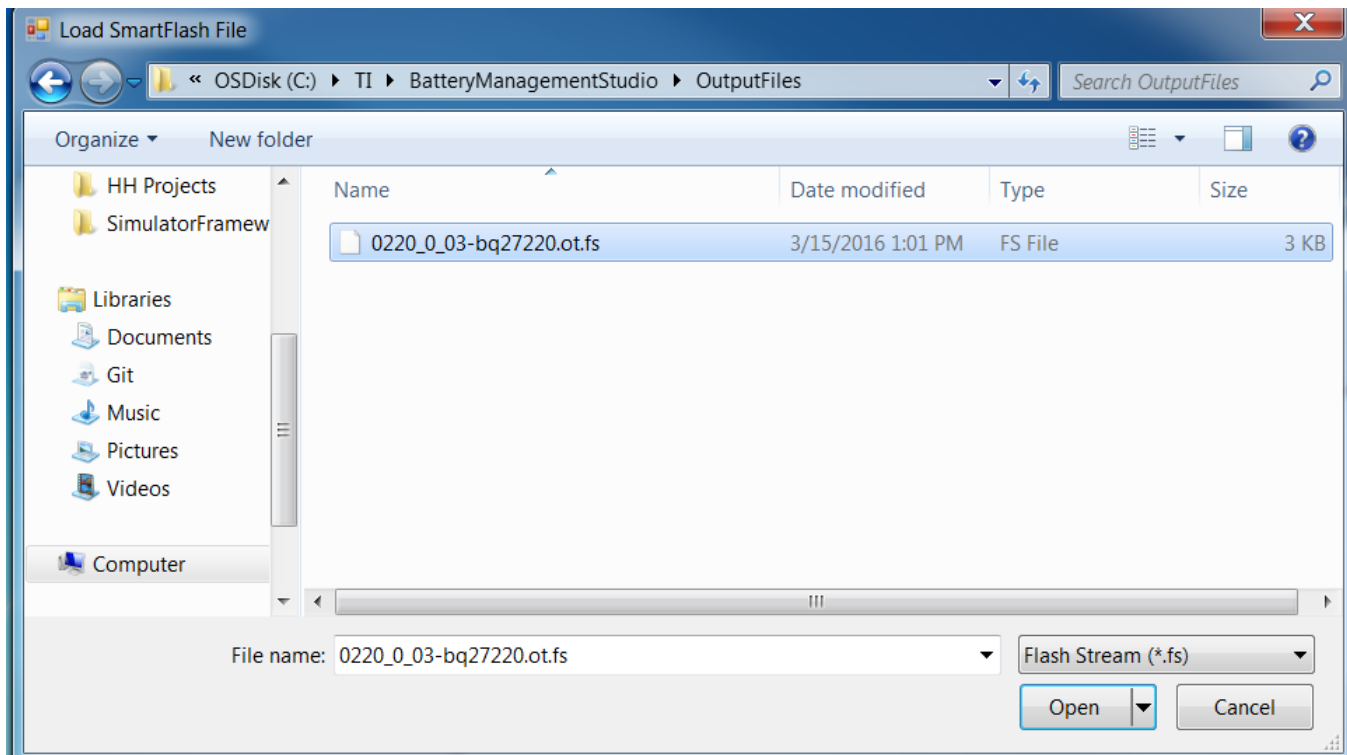

Figure B-9. Open .OTFS File

B.11 Program OTP

1. Click **Program**.
2. When the *Apply Programming Voltage* pop-up dialog box appears, enable 7.4-V power supply and click **OK**.
3. After a brief, approximately 1-second, delay for OTP programming and when the *Remove Programming Voltage* pop-up dialog box appears, disable the power supply and click **OK**.

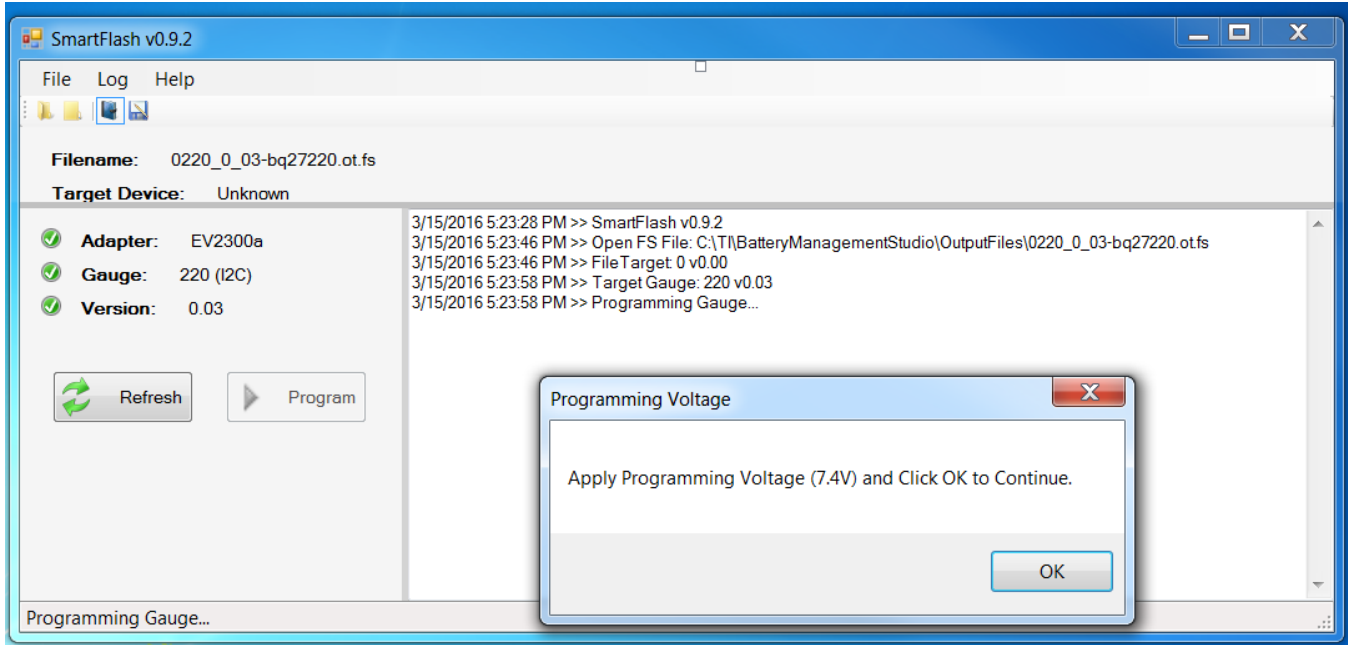

Figure B-10. Apply 7.4 V

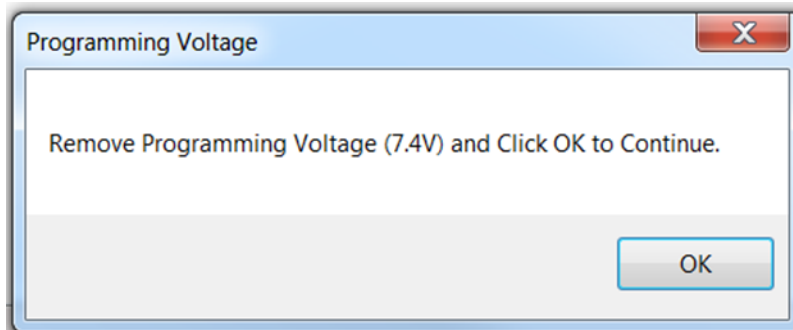

Figure B-11. Program OTP

B.12 Confirm Success

1. Confirm the message *Programming completed successfully!* from the log window.
2. The device is now fully programmed.

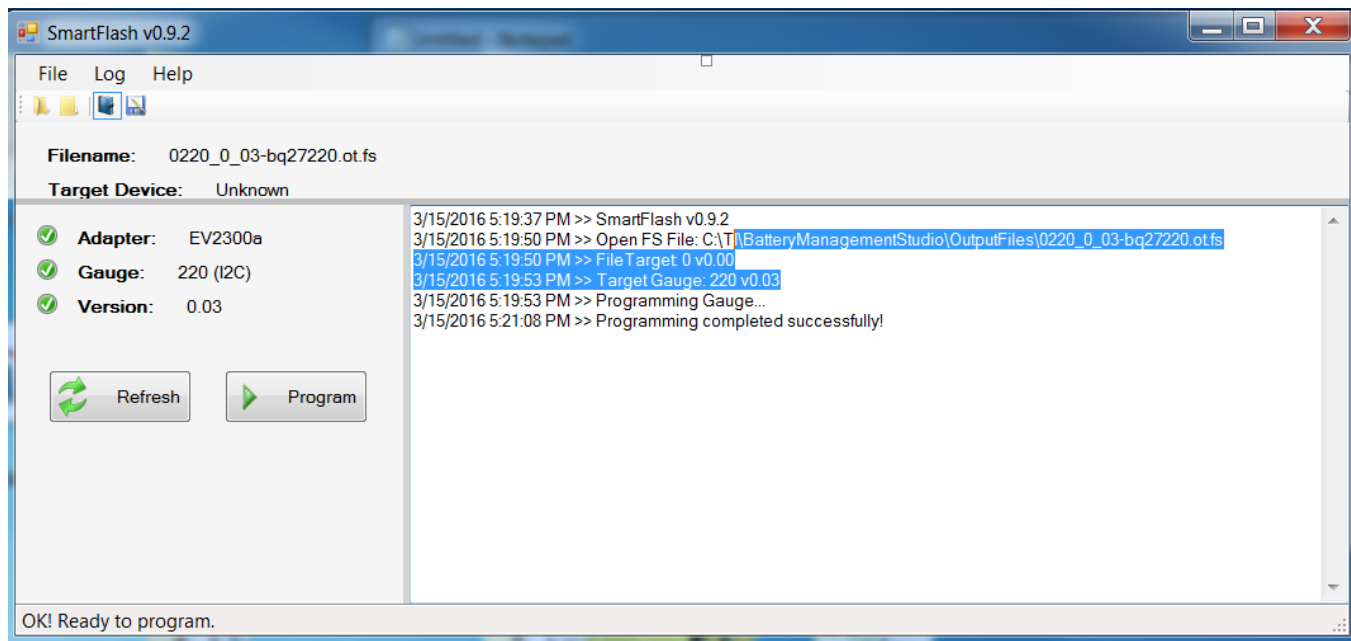

Figure B-12. Confirm Success

Glossary

| | |
|------------------|--|
| ACK | Acknowledge character |
| ADC | Analog-to-digital converter |
| BCA | Board calibration |
| BI | Battery insert |
| CC | Coulomb counter |
| CCA | Coulomb counter calibration |
| CE | Chip enable |
| CHARGE Mode | Refers to a mode to where the gauge read $Current() > \mathbf{Chg\ Current\ Threshold}$ for at least 1 second. |
| Clear | Refers to a bit in a register becoming a logic LOW or 0. The Battery Management Studio (bqStudio) software represents a clear bit with the color green . |
| cWh | Centiwatt-hour |
| CMT | Current measurement time |
| DISCHARGE Mode | Refers to a mode where the gauge read $Current() < (-)\mathbf{Dsg\ Current\ Threshold}$ for at least 1 second. |
| DOD | Depth of discharge in percent as related to Qmax. 100% corresponds to empty battery. |
| DOD0 | Depth of discharge that was looked up in the DOD (OCV) table based on OCV measurement in relaxed state. |
| EOC | End of charge |
| FC | Fully charged |
| FCC | Full charge capacity. Total capacity of the battery compensated for present load current, temperature, and aging effects (reduction in chemical capacity and increase in internal impedance). |
| FIFO | First in, first out |
| Flag | This word usually represents a read-only status bit that indicates some action has occurred or is occurring. This bit typically cannot be modified. The flags are set and cleared automatically by the fuel gauge. |
| FVCA | Fast voltage and current acquisition |
| GPIO | General-purpose input output |
| HDQ | High-speed data queue |
| IC | Integrated circuit |
| ID | Identification |
| IO | Input or output |
| I ² C | Inter-integrated circuit |
| LDO | Low dropout |
| LSB | Least significant bit |
| LT | Lifetime |
| MAC | Manufacturer Access Control |
| mAh | Milliamp-hour |
| MSB | Most significant bit |
| mWh | Milliwatt-hour |
| NACK | Negative acknowledge character |
| NTC | Negative temperature coefficient |
| OCV | Open-circuit voltage. Voltage measured on fully-relaxed battery with no load applied. |
| OTC | Overtemperature in charge |
| OTD | Overtemperature in discharge |
| PFC | Pin function code |
| POR | Power-on reset |
| Qmax | Maximum chemical capacity |
| QC | Qualification and calculation |

| | |
|-----------------|--|
| QT | Qualification time |
| RELAXATION Mode | Refers to a mode to where the gauge read <i>Current()</i> < Quit Current for at least 60 seconds. |
| RM | Remaining capacity |
| RW | Read or write |
| SCL | Serial clock: programmable serial clock used in the I ² C interface |
| SDA | Serial data: serial data bus in the I ² C interface |
| SE | Shutdown enable |
| Set | Refers to a bit in a register becoming a logic HIGH or 1. The Battery Management Studio (bqStudio) software represents a set bit with the color red . |
| SOC | State-of-charge in percent related to FCC |
| SOC1 | State-of-charge initial |
| SOCF | State-of-charge final |
| System | The word system is sometimes used in this document. When used, it always means a host system that is consuming current from the battery pack. |
| TCA | Terminate charge alarm |
| TMT | Temperature measurement time |
| TS | Temperature status |
| TTE | Time-to-empty |
| TTF | Time-to-full |
| VIT | Voltage, current, temperature |
| VMT | Voltage measurement time |

Revision History

NOTE: Page numbers for previous revisions may differ from page numbers in the current version.

| DATE | REVISION | NOTES |
|------------|----------|-----------------|
| April 2016 | * | Initial Release |

IMPORTANT NOTICE

Texas Instruments Incorporated and its subsidiaries (TI) reserve the right to make corrections, enhancements, improvements and other changes to its semiconductor products and services per JESD46, latest issue, and to discontinue any product or service per JESD48, latest issue. Buyers should obtain the latest relevant information before placing orders and should verify that such information is current and complete. All semiconductor products (also referred to herein as "components") are sold subject to TI's terms and conditions of sale supplied at the time of order acknowledgment.

TI warrants performance of its components to the specifications applicable at the time of sale, in accordance with the warranty in TI's terms and conditions of sale of semiconductor products. Testing and other quality control techniques are used to the extent TI deems necessary to support this warranty. Except where mandated by applicable law, testing of all parameters of each component is not necessarily performed.

TI assumes no liability for applications assistance or the design of Buyers' products. Buyers are responsible for their products and applications using TI components. To minimize the risks associated with Buyers' products and applications, Buyers should provide adequate design and operating safeguards.

TI does not warrant or represent that any license, either express or implied, is granted under any patent right, copyright, mask work right, or other intellectual property right relating to any combination, machine, or process in which TI components or services are used. Information published by TI regarding third-party products or services does not constitute a license to use such products or services or a warranty or endorsement thereof. Use of such information may require a license from a third party under the patents or other intellectual property of the third party, or a license from TI under the patents or other intellectual property of TI.

Reproduction of significant portions of TI information in TI data books or data sheets is permissible only if reproduction is without alteration and is accompanied by all associated warranties, conditions, limitations, and notices. TI is not responsible or liable for such altered documentation. Information of third parties may be subject to additional restrictions.

Resale of TI components or services with statements different from or beyond the parameters stated by TI for that component or service voids all express and any implied warranties for the associated TI component or service and is an unfair and deceptive business practice. TI is not responsible or liable for any such statements.

Buyer acknowledges and agrees that it is solely responsible for compliance with all legal, regulatory and safety-related requirements concerning its products, and any use of TI components in its applications, notwithstanding any applications-related information or support that may be provided by TI. Buyer represents and agrees that it has all the necessary expertise to create and implement safeguards which anticipate dangerous consequences of failures, monitor failures and their consequences, lessen the likelihood of failures that might cause harm and take appropriate remedial actions. Buyer will fully indemnify TI and its representatives against any damages arising out of the use of any TI components in safety-critical applications.

In some cases, TI components may be promoted specifically to facilitate safety-related applications. With such components, TI's goal is to help enable customers to design and create their own end-product solutions that meet applicable functional safety standards and requirements. Nonetheless, such components are subject to these terms.

No TI components are authorized for use in FDA Class III (or similar life-critical medical equipment) unless authorized officers of the parties have executed a special agreement specifically governing such use.

Only those TI components which TI has specifically designated as military grade or "enhanced plastic" are designed and intended for use in military/aerospace applications or environments. Buyer acknowledges and agrees that any military or aerospace use of TI components which have **not** been so designated is solely at the Buyer's risk, and that Buyer is solely responsible for compliance with all legal and regulatory requirements in connection with such use.

TI has specifically designated certain components as meeting ISO/TS16949 requirements, mainly for automotive use. In any case of use of non-designated products, TI will not be responsible for any failure to meet ISO/TS16949.

Products

| | |
|------------------------------|--|
| Audio | www.ti.com/audio |
| Amplifiers | amplifier.ti.com |
| Data Converters | dataconverter.ti.com |
| DLP® Products | www.dlp.com |
| DSP | dsp.ti.com |
| Clocks and Timers | www.ti.com/clocks |
| Interface | interface.ti.com |
| Logic | logic.ti.com |
| Power Mgmt | power.ti.com |
| Microcontrollers | microcontroller.ti.com |
| RFID | www.ti-rfid.com |
| OMAP Applications Processors | www.ti.com/omap |
| Wireless Connectivity | www.ti.com/wirelessconnectivity |

Applications

| | |
|-------------------------------|--|
| Automotive and Transportation | www.ti.com/automotive |
| Communications and Telecom | www.ti.com/communications |
| Computers and Peripherals | www.ti.com/computers |
| Consumer Electronics | www.ti.com/consumer-apps |
| Energy and Lighting | www.ti.com/energy |
| Industrial | www.ti.com/industrial |
| Medical | www.ti.com/medical |
| Security | www.ti.com/security |
| Space, Avionics and Defense | www.ti.com/space-avionics-defense |
| Video and Imaging | www.ti.com/video |

TI E2E Community

e2e.ti.com