

LMV242

LMV242 Dual Output, Quad-Band GSM/GPRS Power Amplifier Controller



Literature Number: SNWS014B

LMV242

Dual Output, Quad-Band GSM/GPRS Power Amplifier Controller

General Description

The LMV242 is a power amplifier (PA) controller intended for use within an RF transmit power control loop in GSM/GPRS mobile phones. The LMV242 supports all single-supply PA's including InGaP, HBT and bipolar power amplifiers. The device operates with a single supply from 2.6V to 5.5V.

Included in the PA controller are an RF detector, a ramp filter and two selectable output drivers that function as error amplifiers for two different bands. The LMV242 input interface consists two analog and two digital inputs. The analog inputs are the RF input, Ramp voltage input. The digital inputs perform the function of "Band Select" and "Shutdown/Transmit Enable" respectively. The "Band Select" function enables either of two outputs, namely OUT1 when BS = High, or output OUT2 when BS = Low. The output that is not enabled is pulled low to the minimum output voltage. The LMV242 is active in the case TX_EN = High. When TX_EN = Low the device is in a low power consumption shutdown mode. During shutdown both outputs will be pulled low to the minimum output voltage. Individual PA characteristics are accommodated by a user selectable external RC combination.

The LMV242 is offered in fully tested die form as well as in a 10-lead LLP package and is therefore especially suitable for small footprint PA module solutions.

Features

- Support of InGaP HBT, bipolar technology
- Quad-band operation
- Shutdown mode for power save in R_x slot
- Integrated ramp filter
- 50 dB RF detector
- GPRS compliant
- External loop compensation option
- Accurate temperature compensation
- LLP package 3x3 mm and fully tested die sales

Applications

- GSM/GPRS/TDMA/TD_SCDMA mobile phone
- Pulse RF control
- Wireless LAN
- GSM/GPRS power amplifier module
- Transmit module

Typical Application

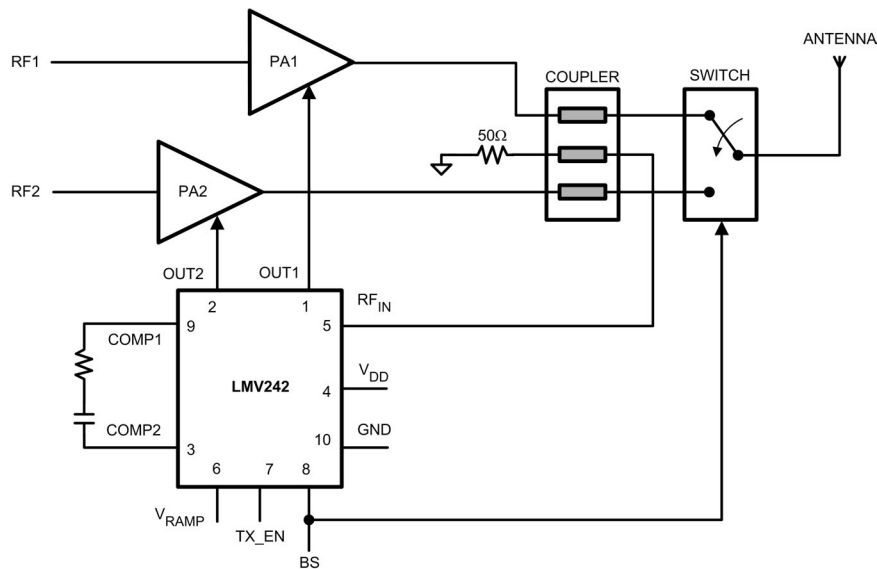

20079501

Absolute Maximum Ratings (Note 1)

If Military/Aerospace specified devices are required, please contact the National Semiconductor Sales Office/Distributors for availability and specifications.

Supply Voltage	
$V_{DD} - GND$	6.5V Max
ESD Tolerance (Note 2)	
Human Body Model	2 kV
Machine Model	200V
Storage Temperature Range	-65°C to 150°C
Junction Temperature (Note 6)	150°C Max

Mounting Temperature

Infrared or convection (20 sec)

235°C

Operating Ratings (Note 1)

Supply Voltage	2.6V to 5.5V
Operating Temperature Range	-40°C to +85°C
V_{RAMP} Voltage Range	0V to 2V
RF Frequency Range	450 MHz to 2 GHz

2.6V Electrical Characteristics

Unless otherwise specified, all limits are guaranteed to $T_J = 25^\circ\text{C}$.
 $V_{DD} = 2.6\text{V}$. **Boldface** limits apply at temperature extremes (Note 4).

Symbol	Parameter	Condition	Min	Typ	Max	Units
I_{DD}	Supply Current	$V_{OUT} = (V_{DD} - GND)/2$		6.9	9 12	mA
		In Shutdown (TX_EN = 0V) $V_{OUT} = (V_{DD} - GND)/2$		0.2	30	μA
V_{HIGH}	Logic Level to Enable Power	(Note 7)	1.8			V
V_{LOW}	Logic Level to Disable Power	(Note 7)			0.8	V
T_{ON}	Turn-on-Time from Shutdown			3.6	6	μs
I_{EN}, I_{BS}	Current into TX_EN and BS Pin			0.03	5	μA
RAMP Amplifier						
V_{RD}	V_{RAMP} Deadband		155	206	265	mV
$1/R_{RAMP}$	Transconductance	(Note 8)	70	96	120	$\mu\text{A/V}$
$I_{OUT RAMP}$	Ramp Amplifier Output Current	$V_{RAMP} = 2\text{V}$	100	162		μA
RF Input						
P_{IN}	RF Input Power Range (Note 5)	20 k Ω // 68 pF between V_{COMP1} and V_{COMP2}		-50 0		dBm
				-63 -13		dBV
	Logarithmic Slope (Note 9)	@ 900 MHz, 20 k Ω // 68 pF between V_{COMP1} and V_{COMP2}		-1.74		$\mu\text{A/dB}$
				-1.62		
				-1.60		
				-1.59		
	Logarithmic Intercept (Note 9)	@ 900 MHz, 20 k Ω // 68 pF between V_{COMP1} and V_{COMP2}		-50.4		dBm
				-52.3		
				-51.9		
				-52.3		
R_{IN}	DC Resistance	(Note 8)		55.7		Ω
Error Amplifier						
GBW	Gain-Bandwidth Product	(Note 8)		5.1		MHz

2.6V Electrical Characteristics

Unless otherwise specified, all limits are guaranteed to $T_J = 25^\circ\text{C}$.
 $V_{DD} = 2.6\text{V}$. **Boldface** limits apply at temperature extremes (Note 4). (Continued)

Symbol	Parameter	Condition	Min	Typ	Max	Units
V_O	Output Swing from Rail	From Positive Rail, Sourcing, $I_O = 7\text{ mA}$		47	90 115	mV
		From Negative Rail Sinking, $I_O = -7\text{ mA}$		52	90 115	
I_O	Output Short Circuit Current (Note 3)	Sourcing, $V_O = 2.4\text{V}$	10	29.5		mA
		Sinking, $V_O = 0.2\text{V}$	10	27.1		
e_n	Output Referred Noise	$f_{\text{MEASURE}} = 10\text{ KHz}$, RF Input = 1800 MHz, -10 dBm, 20 k Ω // 68 pF between V_{COMP1} and V_{COMP2} , V_{OUT} = 1.4V, set by V_{RAMP} , (Note 8)		700		nV/ $\sqrt{\text{Hz}}$
SR	Slew Rate		2.1	4.4		V/ μs

5.0V Electrical Characteristics

Unless otherwise specified, all limits are guaranteed to $T_J = 25^\circ\text{C}$.
 $V_{DD} = 5.0\text{V}$. **Boldface** limits apply at temperature extremes (Note 4).

Symbol	Parameter	Condition	Min	Typ	Max	Units
I_{DD}	Supply Current	$V_{\text{OUT}} = (V_{DD} - \text{GND})/2$		7.8	12 15	mA
		In Shutdown (TX_EN = 0V) $V_{\text{OUT}} = (V_{DD} - \text{GND})/2$		0.4	30	
V_{HIGH}	Logic Level to Enable Power	(Note 7)	1.8			V
V_{LOW}	Logic Level to Disable Power	(Note 7)			0.8	V
T_{ON}	Turn-on-Time from Shutdown			1.5	6	μs
$I_{\text{EN}}, I_{\text{BS}}$	Current into TX_EN and BS Pin			0.03	5	μA

RAMP Amplifier

V_{RD}	V_{RAMP} Deadband		155	206	265	mV
$1/R_{\text{RAMP}}$	Transconductance	(Note 8)	70	96	120	$\mu\text{A/V}$
$I_{\text{OUT RAMP}}$	Ramp Amplifier Output Current	$V_{\text{RAMP}} = 2\text{V}$	100	168		μA

RF Input

P_{IN}	RF Input Power Range (Note 5)	20 k Ω // 68 pF between V_{COMP1} and V_{COMP2}		-50 0		dBm
				-63 -13		
	Logarithmic Slope (Note 9)	@ 900 MHz, 20 k Ω // 68 pF between V_{COMP1} and V_{COMP2}		-1.79		$\mu\text{A/dB}$
				-1.69		
				-1.67		
				-1.65		
	Logarithmic Intercept (Note 9)	@ 900 MHz, 20 k Ω // 68 pF between V_{COMP1} and V_{COMP2}		-50.2		dBm
				-52.5		
				-52.5		
				-52.9		
R_{IN}	DC Resistance	(Note 8)		55.7		Ω

5.0V Electrical Characteristics

Unless otherwise specified, all limits are guaranteed to $T_J = 25^\circ\text{C}$. $V_{DD} = 5.0\text{V}$. **Boldface** limits apply at temperature extremes (Note 4). (Continued)

Symbol	Parameter	Condition	Min	Typ	Max	Units
Error Amplifier						
GBW	Gain-Bandwidth Product	(Note 8)		5.7		MHz
V_O	Output Swing from Rail	From Positive Rail, Sourcing, $I_O = 7\text{ mA}$		31	80	mV
		From Negative Rail Sinking, $I_O = -7\text{ mA}$		35	80	
I_O	Output Short Circuit Current (Note 3)	Sourcing, $V_O = 4.8\text{V}$	15	31.5		mA
		Sinking, $V_O = 0.2\text{V}$	15	31.5		
e_n	Output Referred Noise	$f_{\text{MEASURE}} = 10\text{ kHz}$, RF Input = 1800 MHz, -10dBm, 20 k Ω // 68 pF between V_{COMP1} and V_{COMP2} , $V_{\text{OUT}} = 1.4\text{V}$, set by V_{RAMP} , (Note 8)		770		nV/ $\sqrt{\text{Hz}}$
SR	Slew Rate		2.5	4.9		V/ μs

Note 1: Absolute Maximum Ratings indicate limits beyond which damage to the device may occur. Operating Ratings indicate conditions for which the device is intended to be functional, but specific performance is not guaranteed. For guaranteed specifications and the test conditions, see the Electrical Characteristics.

Note 2: Human body model: 1.5 k Ω in series with 100 pF.

Note 3: The output is not short circuit protected internally. External protection is necessary to prevent overheating and destruction or adverse reliability.

Note 4: Electrical Table values apply only for factory testing conditions at the temperature indicated. Factory testing conditions result in very limited self-heating of the device such that $T_J = T_A$. No guarantee of parametric performance is indicated in the electrical tables under conditions of internal self-heating where $T_J > T_A$.

Note 5: Power in dBm = dBm + 13 when the impedance is 50 Ω .

Note 6: The maximum power dissipation is a function of $T_{J(\text{MAX})}$, θ_{JA} and T_A . The maximum allowable power dissipation at any ambient temperature is $P_D = (T_{J(\text{MAX})} - T_A)/\theta_{JA}$. All numbers apply for packages soldered directly into a PC board.

Note 7: All limits are guaranteed by design or statistical analysis.

Note 8: Typical values represent the most likely parametric norm.

Note 9: Slope and intercept are calculated from graphs " V_{OUT} vs. RF input power" where the current is obtained by division of the voltage by 20 k Ω .

Connection Diagrams

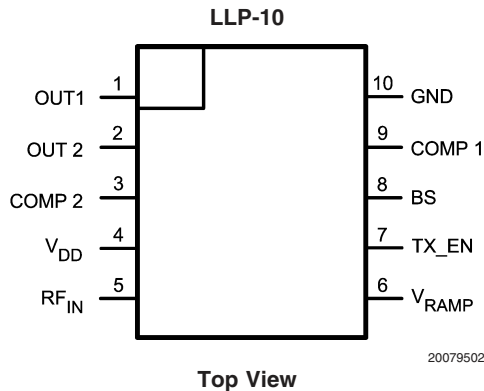

Bond Pad Layout

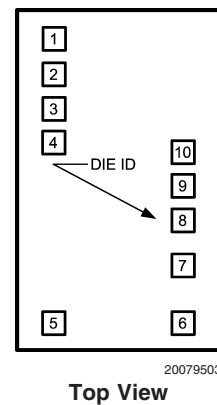

Bond Pad mechanical Dimensions

Signal Name	Pad Number	X/Y Coordinates		Pad Size	
		X	Y	X	Y
Out 1	1	-281	617	92	92
Out 2	2	-281	490	92	92
Comp2	3	-281	363	92	92
V _{DD}	4	-281	236	92	92
RF _{IN}	5	-281	-617	92	92
V _{RAMP}	6	281	-617	92	92
TX_EN	7	281	-360	92	92
BS	8	281	-118	92	92
Comp1	9	281	20	92	92
GND	10	281	187	92	92

Note: Dimensions of the bond pad coordinates are in μm Origin of the coordinates: center of the die Coordinates refer to the center of the bond pad

Pin Descriptions

	Pin	Name	Description
Power Supply	4	V _{DD}	Positive Supply Voltage
	10	GND	Power Ground
Digital Inputs	7	TX_EN	Schmitt-triggered logic input. A LOW shuts down the whole chip for battery saving purposes. A HIGH enables the chip.
	8	BS	Schmitt-triggered Band Select pin. When BS = H, channel 1 (OUT1) is selected, when BS = L, channel 2 (OUT2) is selected.
Analog Inputs	5	RF _{IN}	RF Input connected to the Coupler output with optional attenuation to measure the Power Amplifier (PA) / Antenna RF power levels.
	6	V _{RAMP}	Sets the RF output power level. The useful input voltage range is from 0.2V to 1.8V, although voltages from 0V to V _{DD} are allowed.
Compensation	9	Comp1	Connects an external RC network between the Comp1 pin and the Comp2 pin for an overall loop compensation and to control the closed loop frequency response. Conventional loop stability techniques can be used in selecting this network, such as Bode plots. A good starting value for the RC combination will be C = 68 pF and R = 0 Ω .
	3	Comp2	Frequency compensation pin. The BS signal switches this pin either to OUT1 or to OUT2.
Output	1	Out1	This pin is connected to the PA of either channel 1 or channel 2.
	2	Out2	

Note: 1. All inputs and outputs are referenced to GND (pin 10).

2. For the digital inputs, a LOW is < 0.8V and a HIGH is > 1.8V.

3. RF power detection is performed internally in the LMV242 and only an RF power coupler with optional extra attenuation has to be used.

Ordering Information

Package	Part Number	Package Marking	Transport Media	NSC Drawing
10-Pin LLP	LMV242LD	242LD	1k Units Tape and Reel	LDA10A
	LMV242LDX		4.5k Units tape and Reel	
Tested and Wafer Form	LMV242MDA	No Mark	300 Units Waffle Pack	DA0620035
	LMV242MWA		25 Wafer/Vial	W008

Block Diagram

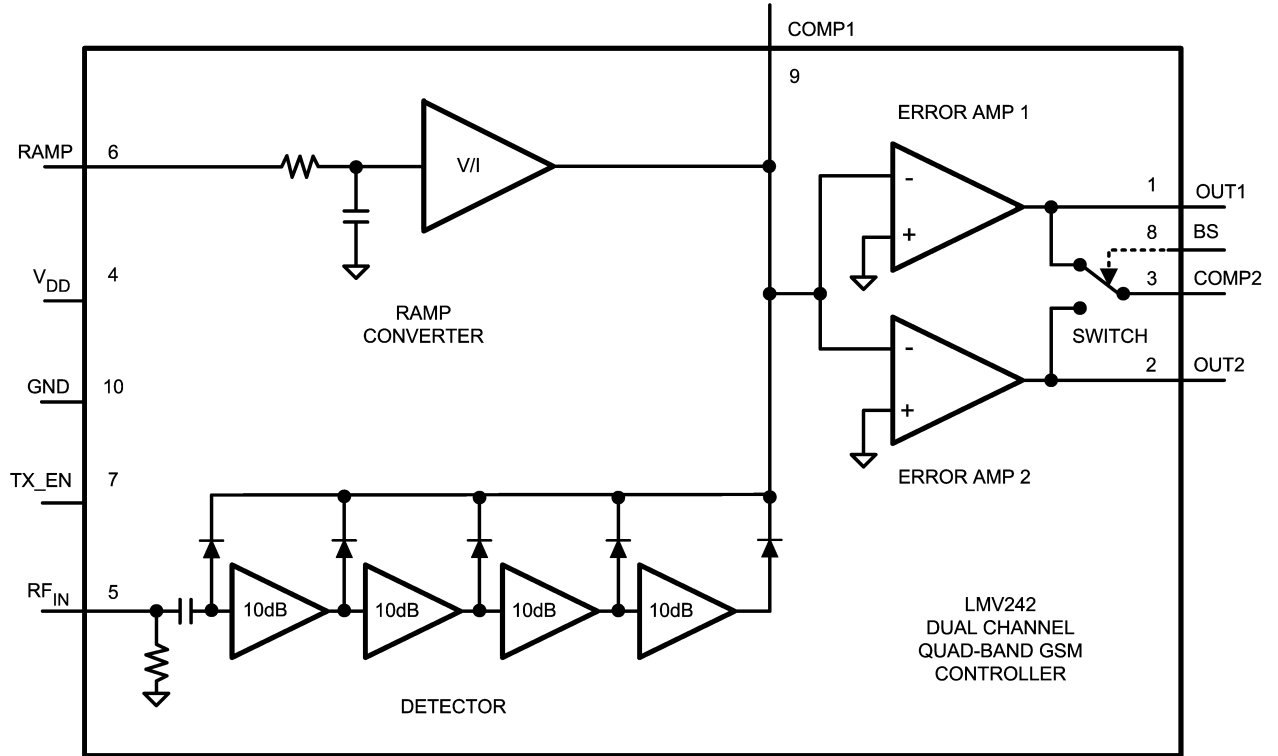

20079504

Typical Performance Characteristics

Unless otherwise specified, $V_{DD} = +2.6V$, $T_J = 25^\circ C$.

Supply Current vs. Supply Voltage

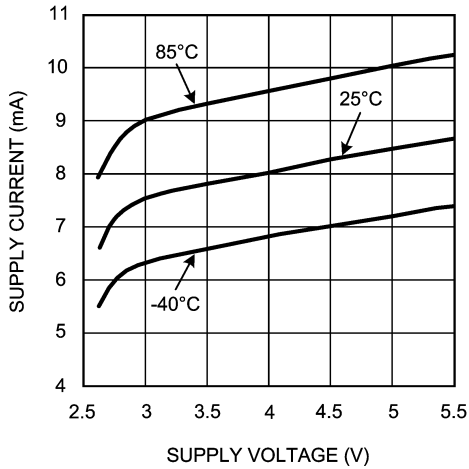

20079505

V_{OUT} and Log Conformance vs. RF Input Power

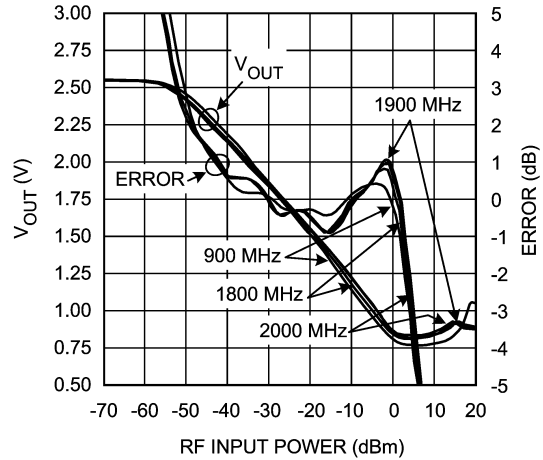

20079506

V_{OUT} and Log Conformance vs. RF Input Power @ 900 MHz

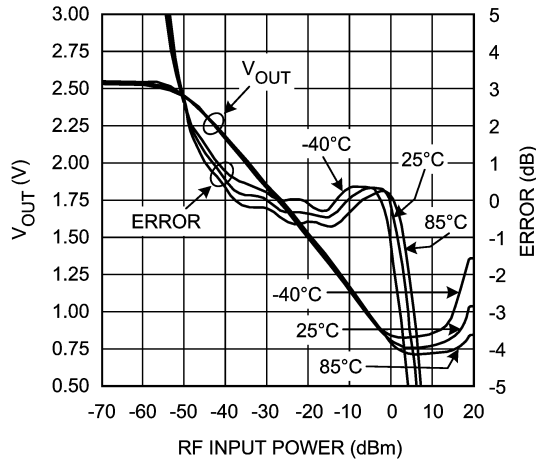

20079507

V_{OUT} and Log Conformance vs. RF Input Power @ 1800 MHz

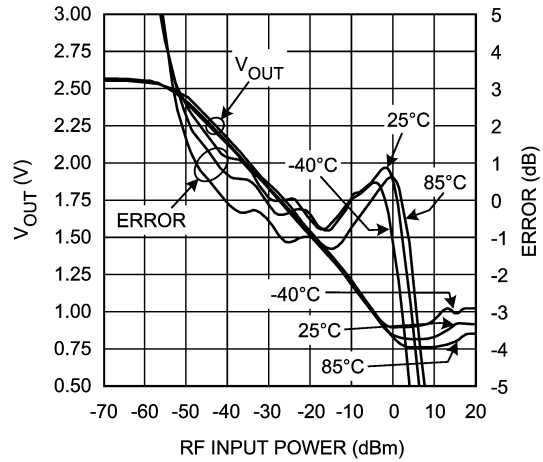

20079508

V_{OUT} and Log Conformance vs. RF Input Power @ 1900 MHz

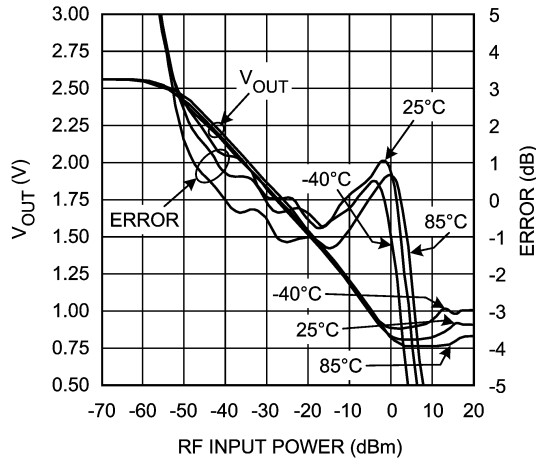

20079514

V_{OUT} and Log Conformance vs. RF Input Power @ 2000 MHz

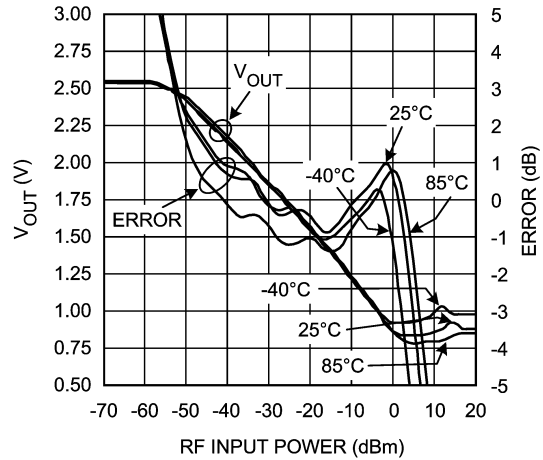

20079515

Typical Performance Characteristics Unless otherwise specified, $V_{DD} = +2.6V$, $T_J = 25^\circ C$. (Continued)

Logarithmic Slope vs. Frequency

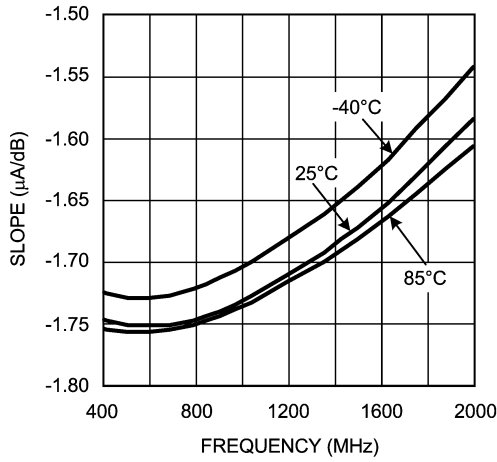

Logarithmic Intercept vs. Frequency

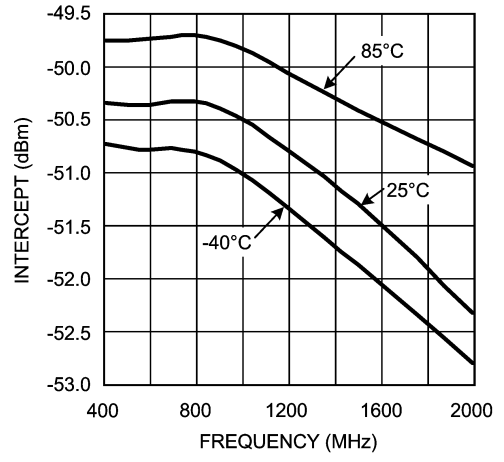

RF Input Impedance vs. Frequency @ Resistance and Reactance

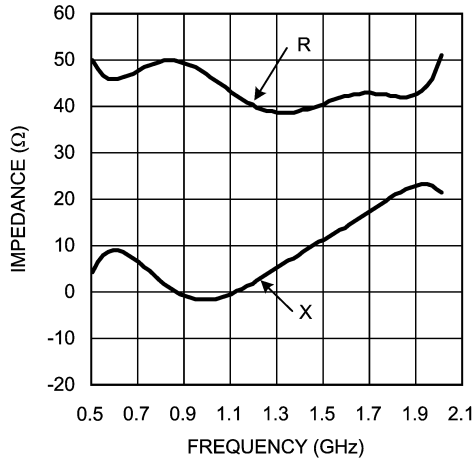

Gain and Phase vs. Frequency

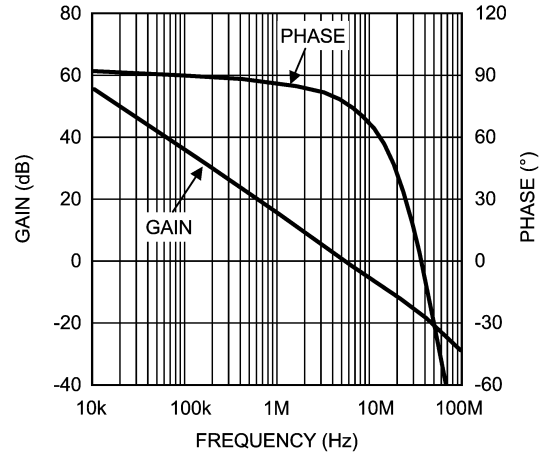

I_{COMP} vs. V_{RAMP}

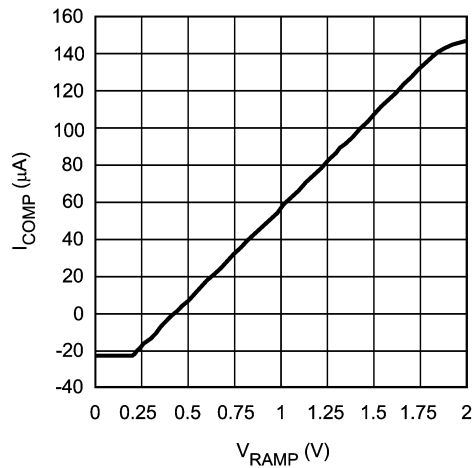

P_{IN} vs. V_{RAMP}

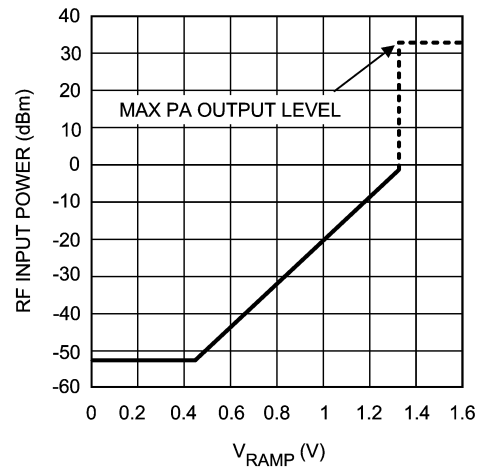

Typical Performance Characteristics Unless otherwise specified, $V_{DD} = +2.6V$, $T_J = 25^\circ C$. (Continued)

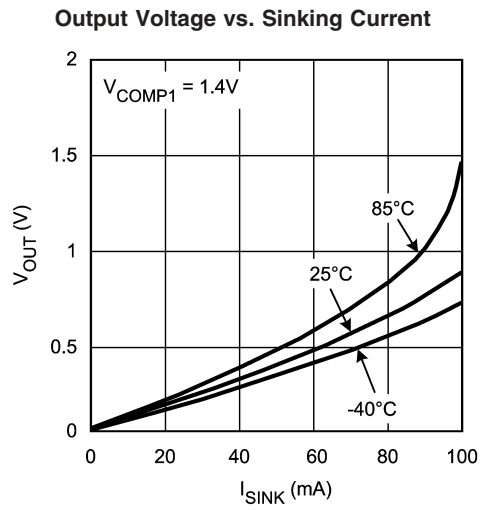
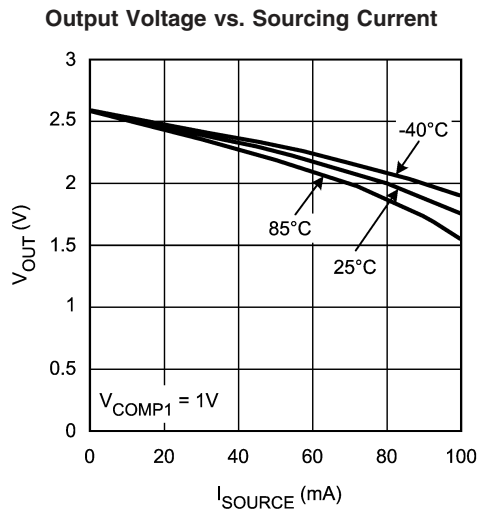
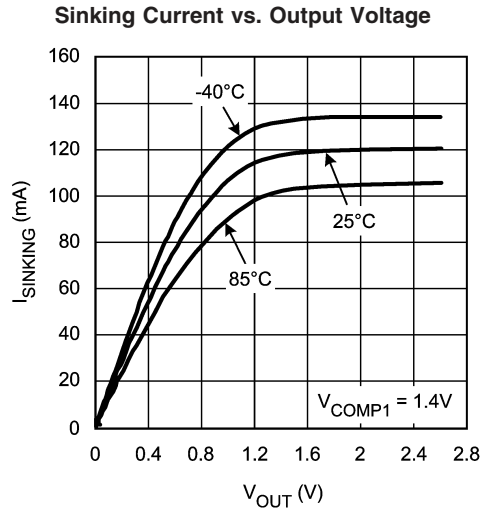
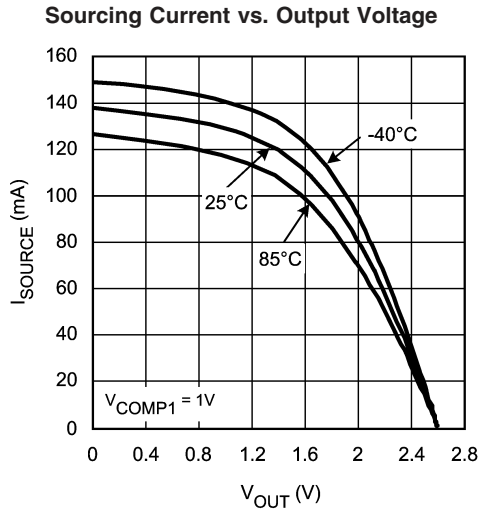

Closed Loop P_{OUT} (PA) vs. V_{RAMP} @ GSM 900 MHz Band

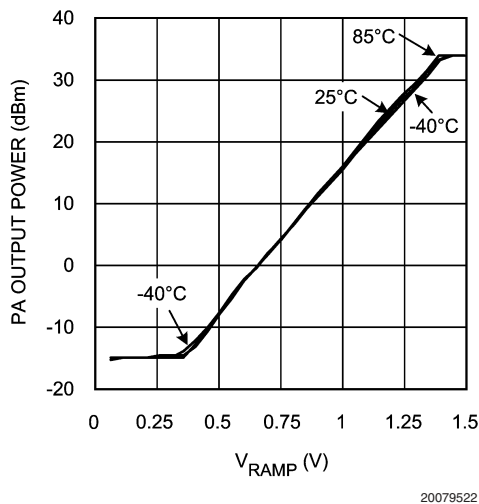

Closed Loop P_{OUT} (PA) vs. V_{RAMP} @ DCS 1800 MHz Band

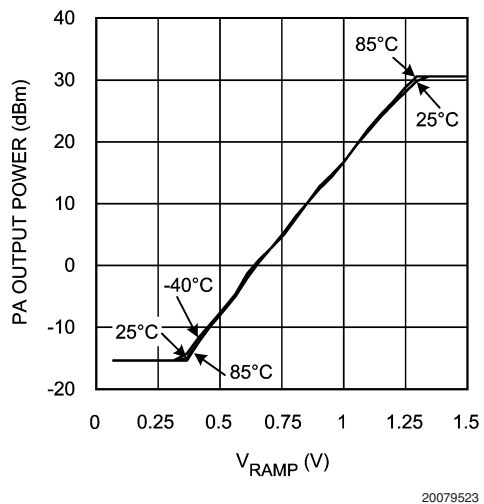

Typical Performance Characteristics Unless otherwise specified, $V_{DD} = +2.6V$, $T_J = 25^\circ C$. (Continued)

Closed Loop P_{OUT} (PA) vs. V_{RAMP} @ PCS 1900 MHz Band

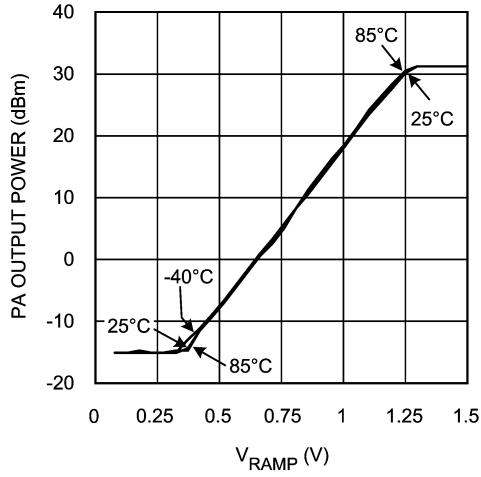

20079524

Closed Loop GSM- 900 MHz Band

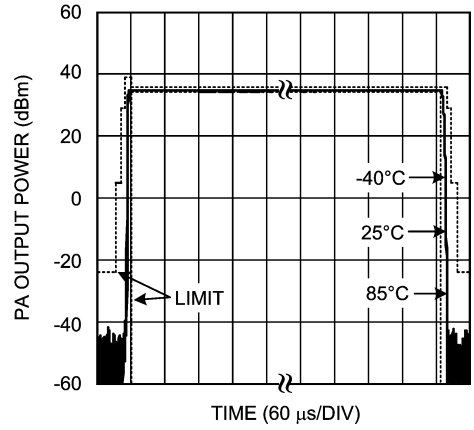

20079525

Closed Loop DCS-1800 MHz Band

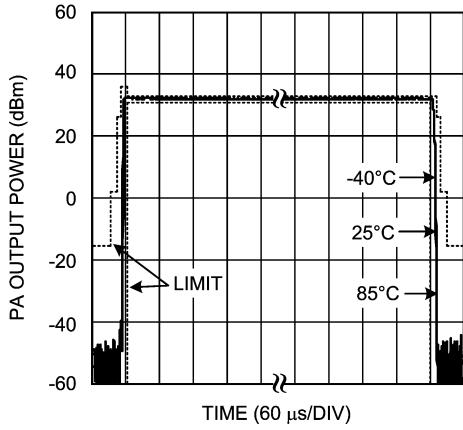

20079526

Closed Loop PCS-1900 MHz Band

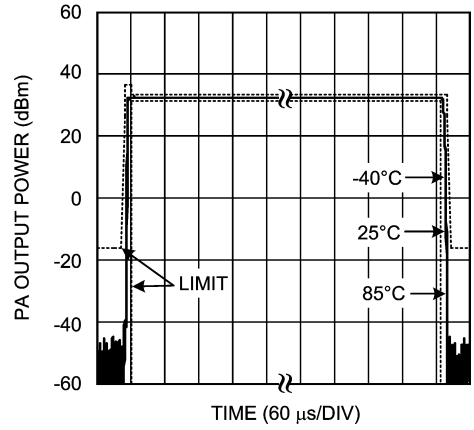

20079527

Application Section

POWER CONTROL PRINCIPLES

The LMV242 is a member of the power loop controller family of National Semiconductor, for quad-band TDMA/GSM solutions. The typical application diagram demonstrates a basic approach for implementing the quad-band solution around an RF Power Amplifier (PA). The LMV242 contains a 50 dB Logamp detector and interfaces directly with the directional coupler.

The LMV242 Base Band (control-) interface consists of 3 signals: TX_EN to enable the device, BS to select either output 1 or output 2 and V_{RAMP} to set the RF output power to the specified level. The LMV242 gives maximum flexibility to meet GSM frequency- and time mask criteria for many different single supply Power Amplifier types like HBT or Mes-FET in GaAs, SiGe or Si technology. This is accomplished by the programmable Ramp characteristic from the Base Band and the TX_EN signal along with the external compensation capacitor.

POWER AMPLIFIER CONTROLLED LOOP

This section gives a general overview and understanding of how a typical Power Amplifier control loop works and how to solve the most common problems confronted in the design.

General Overview

The key benefit of a PA control loop circuit is its immunity to changes in the PA gain control function. When a PA controller is used, the relationship between gain and gain control

voltage (V_{APC}) of the PA is of no consequence to the overall transfer function. It is a function of the controller's V_{RAMP} voltage. Based upon the value of V_{RAMP} , the PA controller will set the gain control voltage of the PA to a level that is necessary to produce the desired output level. Any temperature dependency in the PA gain control function will be eliminated. Also, non-linearity's in the gain transfer function of the PA do not appear in the overall transfer function (P_{OUT} vs. V_{RAMP}). The only requirement is that the gain control function of the PA has to be monotonic. To achieve this, it is crucial, that the LMV242's detector is temperature stable.

Typical PA Closed Loop Control Setup

A typical setup of PA control loop is depicted in *Figure 1*. Beginning at the output of the Power Amplifier (PA), this signal is fed, usually via a directional coupler, to a detector. The error between the detector output current I_{DET} and the ramp current I_{RAMP} , representing the selected power setting, drives the inverting input of an op amp, configured as an integrator. A reference voltage drives the non-inverting input of the op amp. Finally the output of the integrator op amp drives the gain control input of the power amplifier, which sets the output power. The loop is stabilized when I_{DET} is equal to I_{RAMP} . Lets examine how this circuit works in detail.

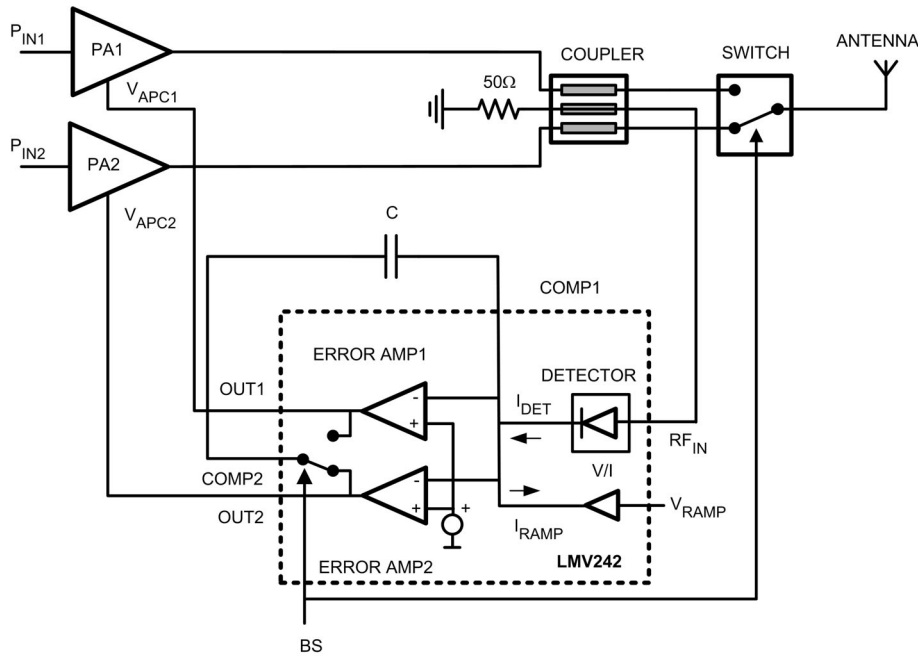

20079528

FIGURE 1. PA Control Loop

Application Section (Continued)

We will assume initially that the output of the PA is at some low level and that the V_{RAMP} voltage is at 1V. The V/I converter converts the V_{RAMP} voltage to a sinking current I_{RAMP} . This current can only come from the integrator capacitor C. Current flow from this direction increases the output voltage of the integrator. The output voltage, which drives the V_{APC} of the PA, increases the gain (we assume that the PA's gain control input has a positive sense, that is, increasing voltage increases gain). The gain will increase, thereby increasing the amplifier's output level until the detector output current equals the ramp current I_{RAMP} . At that point, the current through the capacitor will decrease to zero and the integrator output will be held constant, thereby setting the loop. If capacitor charge is lost over time, output voltage will decrease. However, this leakage will quickly be corrected by additional current from the detector. The loop stabilizes to $I_{DET} = I_{RAMP}$ thereby creating a direct relation between the V_{RAMP} set voltage and the PA output power, independent of the PA's V_{APC} - P_{OUT} characteristics.

Power Control Over Wide Dynamic Range

The circuit as described so far, has been designed to produce a temperature independent output power level. If the detector has a high dynamic range, the circuit can precisely set PA output levels over a wide power range. To set a PA output power level, the reference voltage, V_{RAMP} , is varied. To estimate the response of P_{OUT} vs. V_{RAMP} , P_{IN} vs. V_{RAMP} of the LMV242 should be known ($P_{OUT} = P_{IN} + \text{attenuation}$ as discussed in section 3).

The relation between P_{IN} and V_{RAMP} can be constructed out of 2 curves:

- I_{COMP} vs. V_{RAMP}
- V_{OUT} vs. RF Input Power (detection curve)

I_{OUT} can be calculated by dividing the V_{OUT} of the detection curve by the feedback resistor used for measuring. With the knowledge that $I_{COMP} = I_{OUT}$ in a closed loop the resulting function P_{IN} vs. V_{RAMP} is shown in Figure 2. Extra attenuation should be inserted between PA output and LMV242's P_{IN} to match their dynamic ranges.

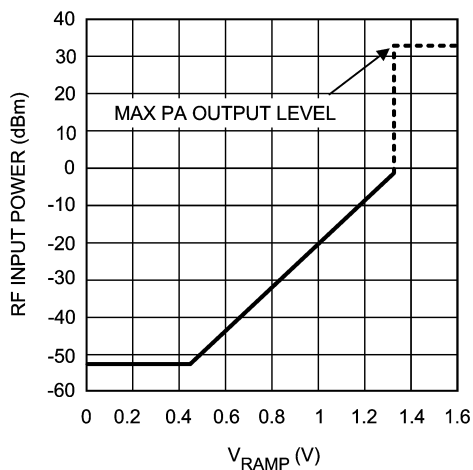
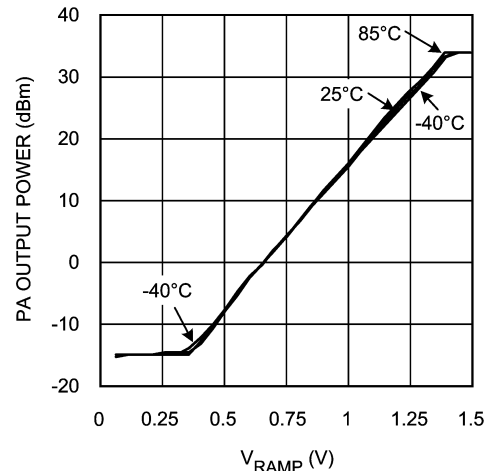

FIGURE 2. P_{IN} vs. V_{RAMP}

Using a closed loop to control the PA has benefits over the use of a directly controlled PA. Non-linearity's and temperature variations present in the PA transfer function do not appear in the overall transfer function, P_{OUT} vs. V_{RAMP} . The response of a typical closed loop is given in Figure 3. The shape of this curve is determined by the response of the controller's detector. Therefore the detector needs to be accurate, temperature stable and preferably linear in dB to achieve a accurately controlled output power. The only requirement for the control loop is that the gain control function of the PA has to be monotonic. With a linear in dB detector, the relation between V_{RAMP} and PA output power becomes linear in dB as well, which makes calibration of the system easy.



20079522

FIGURE 3. Closed Loop Response

The response time of the loop can be controlled by varying the RC time constant of the integrator. Setting this at a low level will result in fast output settling but can result in ringing in the output envelope. Setting the RC time constant to a high value will give the loop good stability but will increase settling time.

ATTENUATION BETWEEN COUPLER AND LMV242 DETECTOR

Figure 4 shows a practical RF power control loop realized by using the National's LMV242 with integrated RF detector. The RF signal from the PA passes through a directional coupler on its way to the antenna. Directional couplers are characterized by their coupling factor, which is in the 10 dB to 30 dB range, typical 20 dB. Because the coupled output must in its own right deliver some power (in this case to the detector), the coupling process takes some power from the main output. This manifests itself as insertion loss, the insertion loss being higher for lower coupling factors.

It is very important to choose the right attenuation between PA output and detector input to achieve power control over the full output power range of the PA. A typical value for the output power of the PA is +35.5 dBm for GSM and +30 dBm for PCS/DCS. In order to accommodate these levels into the LMV242 detection range the minimum required total attenuation is about 35 dBm (please refer to typical performance characteristics in the datasheet and Figure 2). A typical coupler factor is 20 dB. An extra attenuation of about 15 dB should be inserted.

Application Section (Continued)

Extra attenuation Z between the coupler and the RF input of the LMV242 can be achieved by 2 resistors R_X and R_Y according to Figure 3, where

$$Z = 20 \text{ LOG} (R_{IN} / [R_{IN} + R_Y])$$

or

$$R_Y = R_{IN} \cdot \left(10^{\frac{Z}{20}} - 1 \right)$$

e.g. $R_Y = 300\Omega$ results in an attenuation of 16.9 dB.

To prevent reflection back to the coupler the impedance seen by the coupler should be 50Ω (R_O). The impedance consists of R_X in parallel with $R_Y + R_{IN}$. R_X can be calculated with the formula:

$$R_X = [R_O * (R_Y + R_{IN})] / R_Y$$

$$R_X = 50 * [1 + (50 / R_Y)]$$

e.g. with $R_Y = 300\Omega$, $R_{IN} = 50\Omega \rightarrow R_X = 58\Omega$.

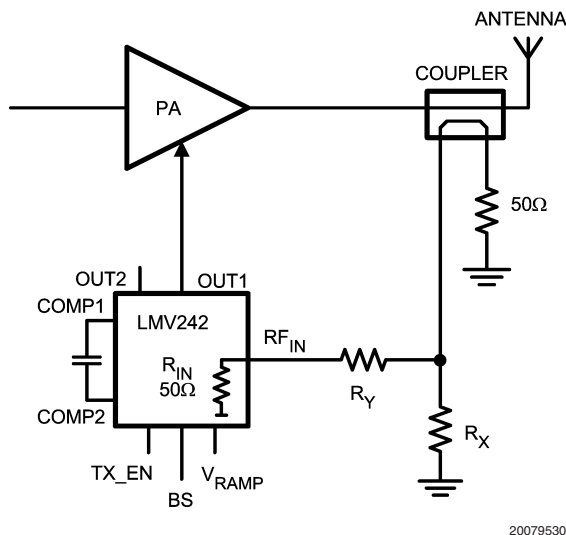

FIGURE 4. Simplified PA Control Loop with Extra Attenuation

BASEBAND CONTROL OF THE LMV242

The LMV242 has 3 baseband-controlled inputs:

- V_{RAMP} signal (Base band DAC ramp signal)
- TX_EN is a digital signal (performs the function “Shutdown/Transmit Enable”).
- Band Select (BS)

V_{RAMP} Signal

The actual V_{RAMP} input value sets the RF output power. By applying a certain mask shape to the “Ramp in” pin, the output voltage level of the LMV242 is adjusting the PA control voltage to get a power level (P_{OUT}/dBm) out of the PA, which is proportional to the single ramp voltage steps. The recommended V_{RAMP} voltage range for RF power control is 0.2V to 2.0V. The V_{RAMP} input will tolerate voltages from 0V to V_{DD} without malfunction or damage. The V_{RAMP} input does not change the output level until the level reaches

about 206 mV, so offset voltages in the DAC or amplifier supplying the R_{AMP} signal will not cause excess RF signal output and increased power consumption.

Transmit Enable

Power consumption requirements are supported by the TX_EN function, which puts the entire chip into a power saving mode to enable maximum standby and talk time while ensuring the output does not glitch excessively during Power-up and Power-down. The device will be active in the case TX_EN = High, or otherwise go to a low power consumption shutdown mode. During shutdown the output is pulled low to minimize the output voltage.

Band Select

The LMV242 is especially suitable for PA control loops with 2 PA's. The 2 outputs to steer the V_{APCS} of the PA's can be controlled with the band select pin. When the band select is LOW output2 is selected, while output1 is selected when band select is HIGH. The not-selected output is pulled low.

Analog Output

The output is driven by a rail-to-rail amplifier capable of both sourcing and sinking. Several curves are given in the “Typical performance characteristics”-section regarding the output. The output voltage vs. sourcing/sinking current curves show the typical voltage drop from the rail over temperature. The sourcing/sinking current vs. output voltage characteristics show the typical charging/discharging current, which the output is capable of delivering at a certain voltage. The output is free from glitches when enabled by TX_EN. When TX_EN is low, the selected output voltage is fixed or near GND.

FREQUENCY COMPENSATION

To compensate and prevent the closed loop arrangement from oscillations and overshoots at the output of the RF detector/error amplifier of the LMV242, the system can be adjusted by means of external RC components connected between Comp1 and Comp2. Exact values heavily depend on PA characteristics. A good starting point is $R = 0\Omega$ and $C = 68 \text{ pF}$. The vast combination of PA's and couplers available preclude a generalized formula for choosing these components. Additional frequency compensation of the closed loop system can be achieved by adding a resistor (and if needed an inductor) between the LMV242's output and the V_{APC} input of the PA. Please contact National Semiconductor for additional support.

TIMING DIAGRAM

In order to meet the timemask specifications for GSM, a good timing between the control signals and the RF signal is essential. According to the specifications the PA's RF output power needs to ramp within 28 μsec with minimum overshoot. To achieve this, the output of the PA controller should ramp at the same time as the RF signal from the Base Band. The ramp signal sets the controllers output to the required value, where the loop needs a certain time to set this output. Therefore the ramp should be set high some time before the output has to be high. How much time depends on the setup and the PA used. If the controllers shutdown functionality is used, the shutdown should be set high about 6 μsec before the ramp is set high.

Application Section (Continued)

The control loop can be configured by the following variables:

- Lead time TX_EN event vs. start GSM burst

- Lead time V_{RAMP} vs. start GSM burst
- Ramp profile
- Loop compensation

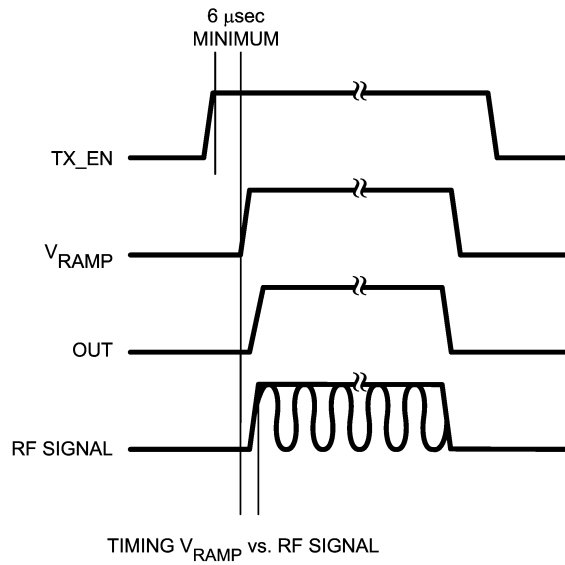

20079531

FIGURE 5. Timing V_{RAMP} vs. RF Signal

10-Pad Bare Die

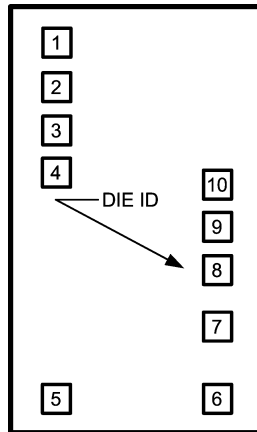

20079503

Die / Wafer Characteristics

Fabrication Attributes

Physical Die Identification	LMV242A
Die Step	A

Physical Attributes

Wafer Diameter	200 mm
Die Size (Drawn)	889 μm x 1562 μm 35.0 mils x 61.5 mils
Thickness	216 μm Nominal
Min Pitch	123 μm Nominal

General Die Information

Bond Pad Opening Size (min)	92 μm x 92 μm
Bond Pad Metallization	0.5% Copper_Bal. Aluminum
Passivation	VOM Nitride
Back Side Metal	Bare Back
Back Side Connection	Floating

Note: Note: Actual die size is rounded to the nearest micron

Physical Dimensions inches (millimeters)

unless otherwise noted

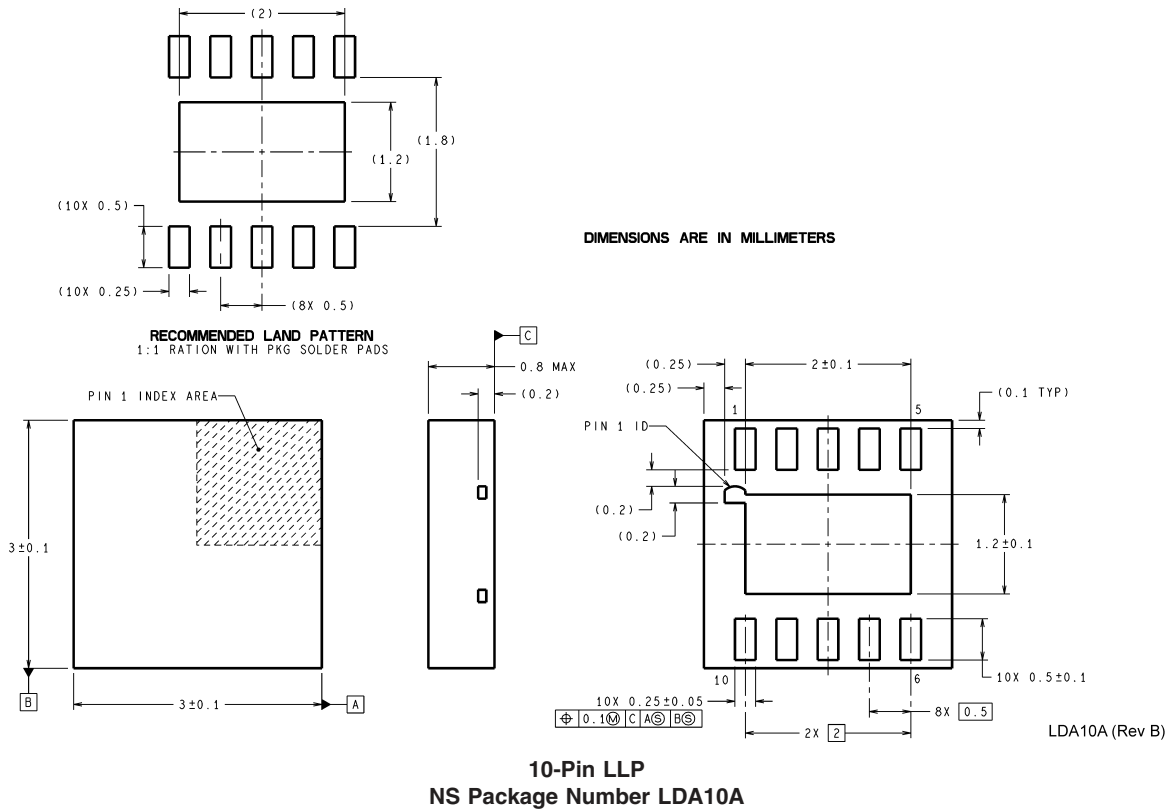

LIFE SUPPORT POLICY

NATIONAL'S PRODUCTS ARE NOT AUTHORIZED FOR USE AS CRITICAL COMPONENTS IN LIFE SUPPORT DEVICES OR SYSTEMS WITHOUT THE EXPRESS WRITTEN APPROVAL OF THE PRESIDENT AND GENERAL COUNSEL OF NATIONAL SEMICONDUCTOR CORPORATION. As used herein:

1. Life support devices or systems are devices or systems which, (a) are intended for surgical implant into the body, or (b) support or sustain life, and whose failure to perform when properly used in accordance with instructions for use provided in the labeling, can be reasonably expected to result in a significant injury to the user.
2. A critical component is any component of a life support device or system whose failure to perform can be reasonably expected to cause the failure of the life support device or system, or to affect its safety or effectiveness.

BANNED SUBSTANCE COMPLIANCE

National Semiconductor certifies that the products and packing materials meet the provisions of the Customer Products Stewardship Specification (CSP-9-111C2) and the Banned Substances and Materials of Interest Specification (CSP-9-111S2) and contain no "Banned Substances" as defined in CSP-9-111S2.



National Semiconductor
Americas Customer
Support Center
Email: new.feedback@nsc.com
Tel: 1-800-272-9959

National Semiconductor
Europe Customer Support Center
Fax: +49 (0) 180-530 85 86
Email: europe.support@nsc.com
Deutsch Tel: +49 (0) 69 9508 6208
English Tel: +44 (0) 870 24 0 2171
Français Tel: +33 (0) 1 41 91 8790

National Semiconductor
Asia Pacific Customer
Support Center
Email: ap.support@nsc.com

National Semiconductor
Japan Customer Support Center
Fax: 81-3-5639-7507
Email: jpn.feedback@nsc.com
Tel: 81-3-5639-7560

www.national.com

IMPORTANT NOTICE

Texas Instruments Incorporated and its subsidiaries (TI) reserve the right to make corrections, modifications, enhancements, improvements, and other changes to its products and services at any time and to discontinue any product or service without notice. Customers should obtain the latest relevant information before placing orders and should verify that such information is current and complete. All products are sold subject to TI's terms and conditions of sale supplied at the time of order acknowledgment.

TI warrants performance of its hardware products to the specifications applicable at the time of sale in accordance with TI's standard warranty. Testing and other quality control techniques are used to the extent TI deems necessary to support this warranty. Except where mandated by government requirements, testing of all parameters of each product is not necessarily performed.

TI assumes no liability for applications assistance or customer product design. Customers are responsible for their products and applications using TI components. To minimize the risks associated with customer products and applications, customers should provide adequate design and operating safeguards.

TI does not warrant or represent that any license, either express or implied, is granted under any TI patent right, copyright, mask work right, or other TI intellectual property right relating to any combination, machine, or process in which TI products or services are used. Information published by TI regarding third-party products or services does not constitute a license from TI to use such products or services or a warranty or endorsement thereof. Use of such information may require a license from a third party under the patents or other intellectual property of the third party, or a license from TI under the patents or other intellectual property of TI.

Reproduction of TI information in TI data books or data sheets is permissible only if reproduction is without alteration and is accompanied by all associated warranties, conditions, limitations, and notices. Reproduction of this information with alteration is an unfair and deceptive business practice. TI is not responsible or liable for such altered documentation. Information of third parties may be subject to additional restrictions.

Resale of TI products or services with statements different from or beyond the parameters stated by TI for that product or service voids all express and any implied warranties for the associated TI product or service and is an unfair and deceptive business practice. TI is not responsible or liable for any such statements.

TI products are not authorized for use in safety-critical applications (such as life support) where a failure of the TI product would reasonably be expected to cause severe personal injury or death, unless officers of the parties have executed an agreement specifically governing such use. Buyers represent that they have all necessary expertise in the safety and regulatory ramifications of their applications, and acknowledge and agree that they are solely responsible for all legal, regulatory and safety-related requirements concerning their products and any use of TI products in such safety-critical applications, notwithstanding any applications-related information or support that may be provided by TI. Further, Buyers must fully indemnify TI and its representatives against any damages arising out of the use of TI products in such safety-critical applications.

TI products are neither designed nor intended for use in military/aerospace applications or environments unless the TI products are specifically designated by TI as military-grade or "enhanced plastic." Only products designated by TI as military-grade meet military specifications. Buyers acknowledge and agree that any such use of TI products which TI has not designated as military-grade is solely at the Buyer's risk, and that they are solely responsible for compliance with all legal and regulatory requirements in connection with such use.

TI products are neither designed nor intended for use in automotive applications or environments unless the specific TI products are designated by TI as compliant with ISO/TS 16949 requirements. Buyers acknowledge and agree that, if they use any non-designated products in automotive applications, TI will not be responsible for any failure to meet such requirements.

Following are URLs where you can obtain information on other Texas Instruments products and application solutions:

Products

Audio	www.ti.com/audio
Amplifiers	amplifier.ti.com
Data Converters	dataconverter.ti.com
DLP® Products	www.dlp.com
DSP	dsp.ti.com
Clocks and Timers	www.ti.com/clocks
Interface	interface.ti.com
Logic	logic.ti.com
Power Mgmt	power.ti.com
Microcontrollers	microcontroller.ti.com
RFID	www.ti-rfid.com
OMAP Mobile Processors	www.ti.com/omap
Wireless Connectivity	www.ti.com/wirelessconnectivity

Applications

Communications and Telecom	www.ti.com/communications
Computers and Peripherals	www.ti.com/computers
Consumer Electronics	www.ti.com/consumer-apps
Energy and Lighting	www.ti.com/energy
Industrial	www.ti.com/industrial
Medical	www.ti.com/medical
Security	www.ti.com/security
Space, Avionics and Defense	www.ti.com/space-avionics-defense
Transportation and Automotive	www.ti.com/automotive
Video and Imaging	www.ti.com/video

TI E2E Community Home Page

e2e.ti.com

Mailing Address: Texas Instruments, Post Office Box 655303, Dallas, Texas 75265
Copyright © 2011, Texas Instruments Incorporated