

# 3.2 x 1.6 x 0.5 (mm) GPS & WiFi Dual Band Triple PCB Substrate Antenna (EVB +AA099) Engineering Specification

## 1. Product Number

H 2 B 1 A G 1 A 2 L 0 2 0 0

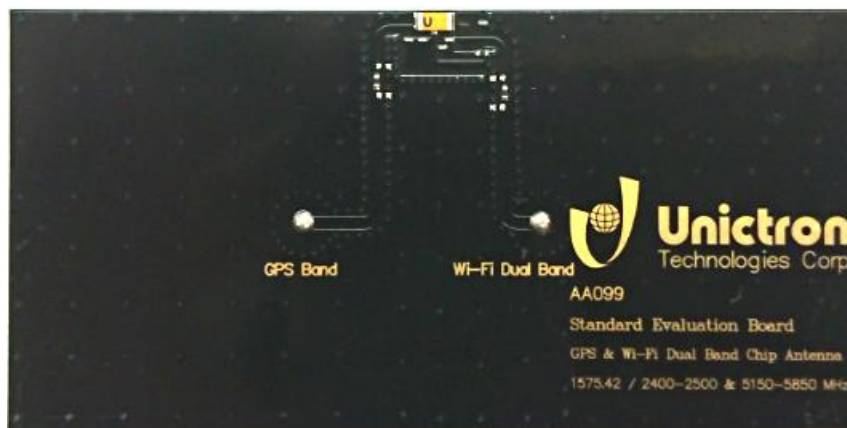

## 2. Features

- \*Stable and reliable in performances
- \*Compact size
- \*RoHS2.0 compliance
- \*SMT processes compatible

## 3. Applications

- \*Navigation systems or position tracking systems
- \*Hand-held devices when GPS and WiFi (802.11a/b/g/n/ac) functions are needed, e.g., PDA, Smart phone, PND, Notebook computer.

## 4. Description

Unictron's AA099 ceramic chip antenna is designed for GPS & Wi-Fi CERTIFIED ac applications, covering frequencies 1.57542 GHz & 2.4~2.5 GHz & 5.15~5.85 GHz. Fabricated with proprietary design and processes, AA099H shows excellent performance and is fully compatible with SMT processes which can decrease the assembly cost and improve device's quality and consistency.

2019-09-20



詠業科技股份有限公司  
Unictron Technologies Corporation  
Website: www.unictron.com

THIS DRAWINGS AND SPECIFICATIONS ARE THE PROPERTY OF UNICTRON TECHNOLOGIES CORPORATION AND SHALL NOT BE REPRODUCED OR USED AS THE BASIS FOR THE MANUFACTURE OR SALE OF APPARATUS OR DEVICES WITHOUT PERMISSION

Prepared by : Jane

Designed by : Ken

Checked by : Mike

Approved by : Herbert

**TITLE :** 3.2 x 1.6 x 0.5 (mm) GPS & WiFi Dual Band Triple PCB Substrate Antenna (EVB+AA099) Engineering Specification

**DOCUMENT NO.**

**H2B1AG1A2L0200**

**REV. B**

## 5. Layout Guide & Electrical Specifications

### 5-1. Layout Guide (Unit : mm)

Solder Land Pattern:

The solder land pattern (gold marking areas) is shown below. Recommendation on matching circuit will be provided according to customer's installation conditions.

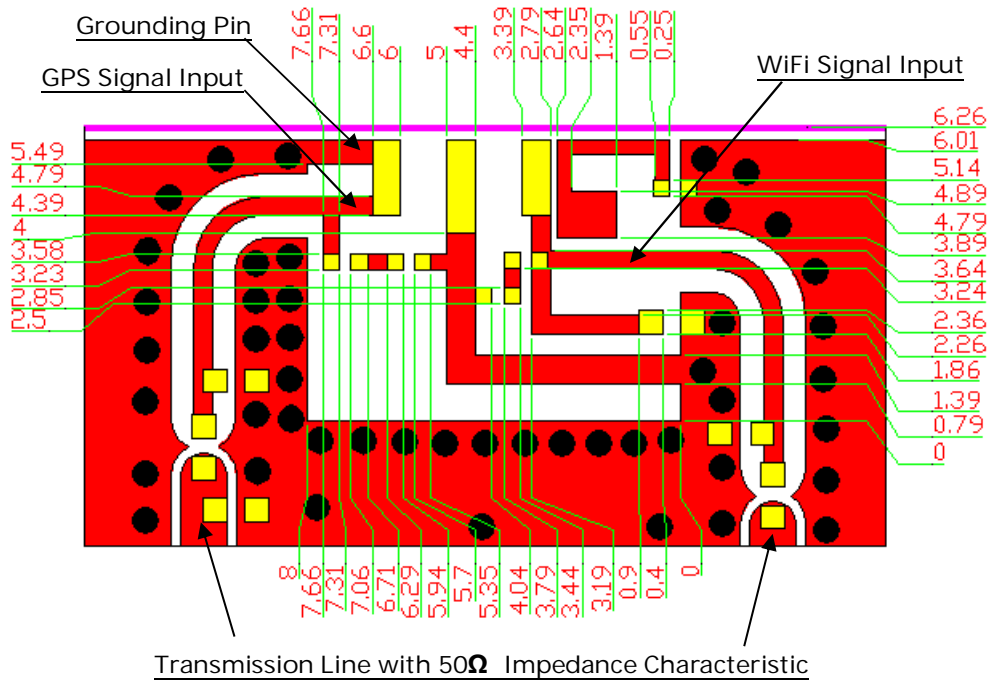

Top View

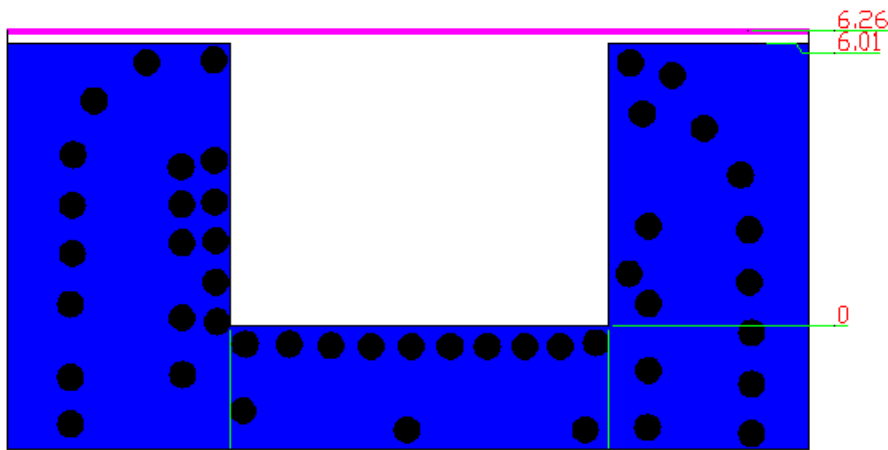

Bottom View



詠業科技股份有限公司  
Unictron Technologies Corporation  
Website: www.unictron.com

THIS DRAWINGS AND SPECIFICATIONS ARE THE PROPERTY OF UNICTRON TECHNOLOGIES CORPORATION AND SHALL NOT BE REPRODUCED OR USED AS THE BASIS FOR THE MANUFACTURE OR SALE OF APPARATUS OR DEVICES WITHOUT PERMISSION

Prepared by : Jane

Designed by : Ken

Checked by : Mike

Approved by : Herbert

**TITLE** : 3.2 x 1.6 x 0.5 (mm) GPS & WiFi Dual Band Triple PCB Substrate Antenna (EVb+AA099) Engineering Specification

**DOCUMENT NO.**

**H2B1AG1A2L0200**

**REV. B**

## 5-2. Electrical Specifications (Evaluation Board Dimensions: 80 x 40 mm<sup>2</sup>)

### 5-2-1. Electrical Table (GPS Band)

Characteristics		Specifications	Unit
Outline Dimensions		3.2 x 1.6 x 0.5	mm
Ground Plane Dimensions		80 x 40	mm
Working Frequency		1575.42	MHz
Isolation(S <sub>21</sub> )		≤ -24 (typical)	dB
VSWR(@ center frequency)*		2 Max.	
Characteristic Impedance		50	Ω
Polarization		Linear Polarization	
Peak Gain	(@ 1575.42 MHz)	1.5 (typical)**	dBi
Efficiency		61 (typical)**	%

\*Center frequency means the frequency with the lowest value in return loss of the chip antenna on the evaluation board.

\*\*A Typical value is for reference only, not guaranteed.

### 5-2-2. Electrical Table (WiFi Band, 2400-2500MHz)

Characteristics		Specifications	Unit
Working Frequency		2400~2500	MHz
Isolation(S <sub>21</sub> )		≤ -8 (typical)	dB
VSWR(@ center frequency)*		2 Max.	
Characteristic Impedance		50	Ω
Polarization		Linear Polarization	
Peak Gain	(@ 2442 MHz)	0.4 (typical)**	dBi
Efficiency		50 (typical)**	%

\*Center frequency means the frequency with the lowest value in return loss of the chip antenna on the evaluation board.

\*\*A Typical value is for reference only, not guaranteed.



詠業科技股份有限公司  
Unictron Technologies Corporation  
Website: www.unictron.com

THIS DRAWINGS AND SPECIFICATIONS ARE THE PROPERTY OF UNICTRON TECHNOLOGIES CORPORATION AND SHALL NOT BE REPRODUCED OR USED AS THE BASIS FOR THE MANUFACTURE OR SALE OF APPARATUS OR DEVICES WITHOUT PERMISSION

Prepared by : Jane

Designed by : Ken

Checked by : Mike

Approved by : Herbert

**TITLE** : 3.2 x 1.6 x 0.5 (mm) GPS & WiFi Dual Band Triple PCB  
Substrate Antenna (EVB+AA099) Engineering  
Specification

**DOCUMENT**  
NO.

**H2B1AG1A2L0200**

REV.  
**B**

5-2-3. Electrical Table (WiFi Band, 5150-5850MHz)

Characteristics		Specifications	Unit
Working Frequency		5150~5850	MHz
Isolation( $S_{21}$ )		$\leq -39$ (typical)	dB
VSWR(@ center frequency)*		3 Max.	
Characteristic Impedance		50	$\Omega$
Polarization		Linear Polarization	
Peak Gain	(@5550 MHz)	2.3 (typical)**	dBi
Efficiency		62 (typical)**	%

\*Center frequency means the frequency with the lowest value in return loss of the chip antenna on the evaluation board.

\*\*A Typical value is for reference only, not guaranteed.

5-2-4. Return Loss & VSWR of GPS Band

Return Loss ( $S_{11}$ )

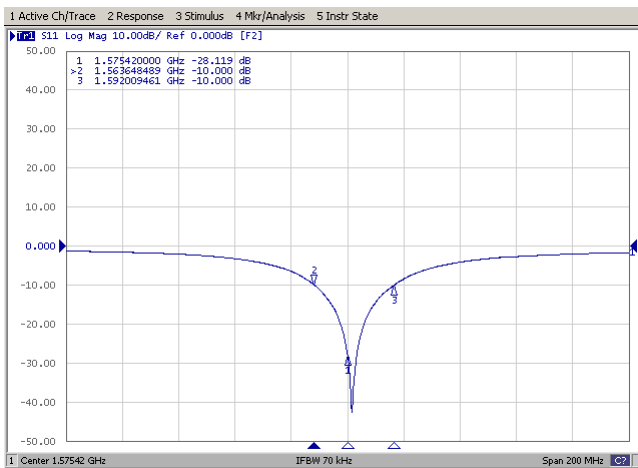

VSWR( $S_{11}$ )

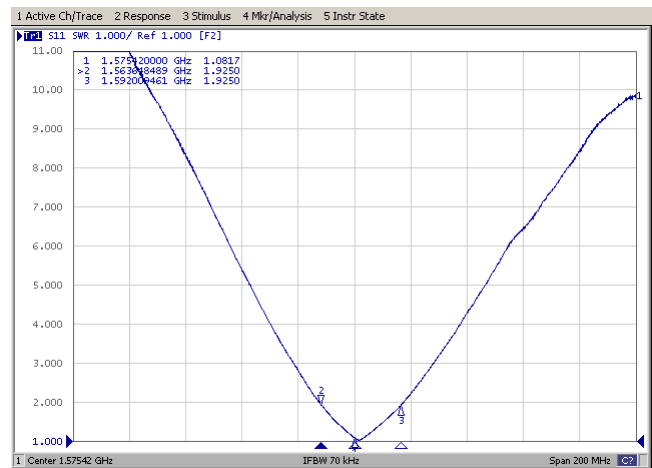

Unictron  
Technologies Corp.  
**2019-09-20**  
Document  
Control Center



**詠業科技股份有限公司**  
Unictron Technologies Corporation  
Website: www.unictron.com

THIS DRAWINGS AND SPECIFICATIONS ARE THE PROPERTY OF UNICTRON TECHNOLOGIES CORPORATION AND SHALL NOT BE REPRODUCED OR USED AS THE BASIS FOR THE MANUFACTURE OR SALE OF APPARATUS OR DEVICES WITHOUT PERMISSION

Prepared by : **Jane**

Designed by : **Ken**

Checked by : **Mike**

Approved by : **Herbert**

**TITLE** : 3.2 x 1.6 x 0.5 (mm) GPS & WiFi Dual Band Triple PCB Substrate Antenna (EVB+AA099) Engineering Specification

**DOCUMENT NO.**

**H2B1AG1A2L0200**

**REV. B**

### 5-2-5. Return Loss & VSWR of WiFi Band

Return Loss (S<sub>11</sub>)

VSWR(S<sub>11</sub>)

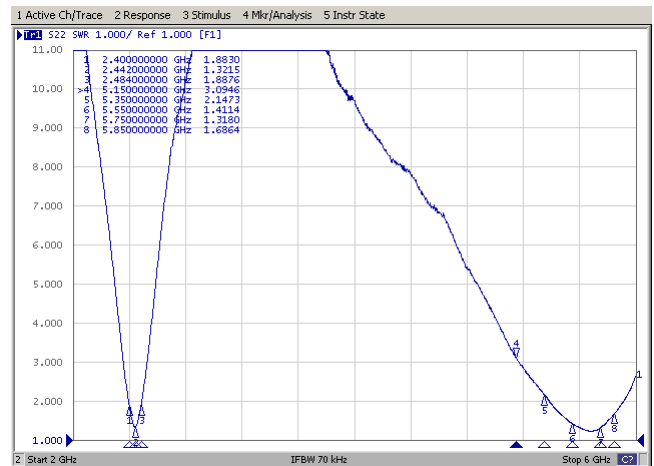
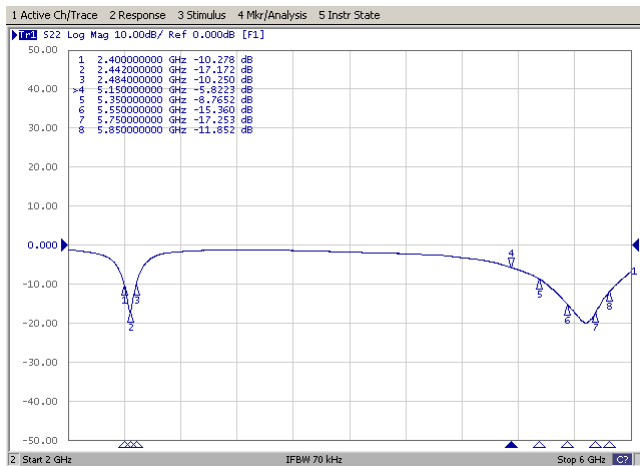

### 5-2-6. Isolation between GPS Band & WiFi Band

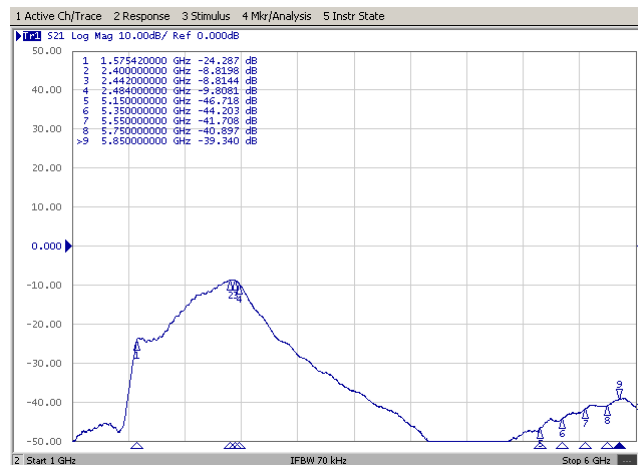

Unictron  
Technologies Corp.  
2019-09-20  
Document  
Control Center



詠業科技股份有限公司  
Unictron Technologies Corporation  
Website: www.unictron.com

THIS DRAWINGS AND SPECIFICATIONS ARE THE PROPERTY OF UNICTRON TECHNOLOGIES CORPORATION AND SHALL NOT BE REPRODUCED OR USED AS THE BASIS FOR THE MANUFACTURE OR SALE OF APPARATUS OR DEVICES WITHOUT PERMISSION

Prepared by : Jane

Designed by : Ken

Checked by : Mike

Approved by : Herbert

TITLE : 3.2 x 1.6 x 0.5 (mm) GPS & WiFi Dual Band Triple PCB  
Substrate Antenna (EVb+AA099) Engineering  
Specification

DOCUMENT  
NO.

H2B1AG1A2L0200

REV.  
B

## 6. Outline Dimensions of Antenna & Evaluation Board (unit: mm)

### 6-1. Antenna Dimensions

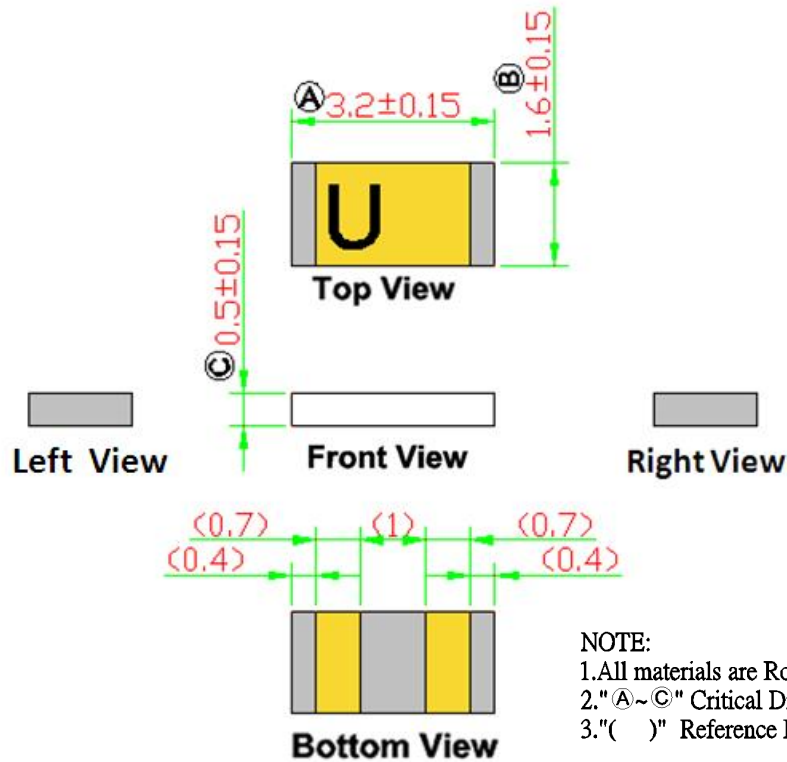

### PIN Definitions

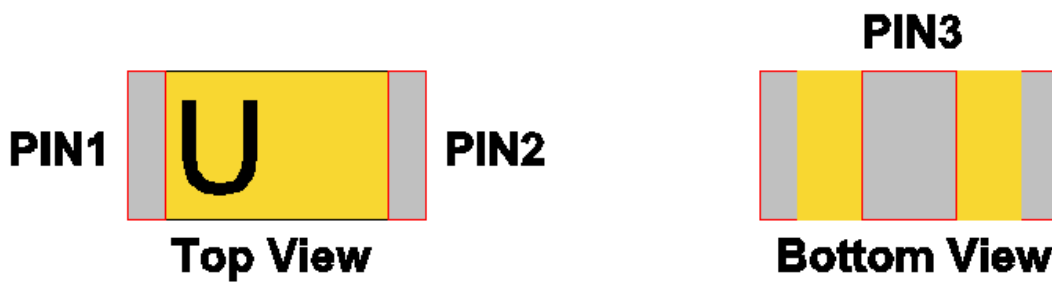

PIN	1	2	3
Soldering PAD	GPS Input	Wi-Fi dual band Input	Ground



詠業科技股份有限公司  
 Unictron Technologies Corporation  
 Website: www.unictron.com

THIS DRAWINGS AND SPECIFICATIONS ARE THE PROPERTY OF UNICTRON TECHNOLOGIES CORPORATION AND SHALL NOT BE REPRODUCED OR USED AS THE BASIS FOR THE MANUFACTURE OR SALE OF APPARATUS OR DEVICES WITHOUT PERMISSION

Prepared by : **Jane**      Designed by : **Ken**      Checked by : **Mike**      Approved by : **Herbert**

<b>TITLE</b> : 3.2 x 1.6 x 0.5 (mm) GPS & WiFi Dual Band Triple PCB Substrate Antenna (EVB+AA099) Engineering Specification	<b>DOCUMENT NO.</b>	<b>H2B1AG1A2L0200</b>	<b>REV.</b>
			<b>B</b>

6-2. Evaluation Board with Antenna

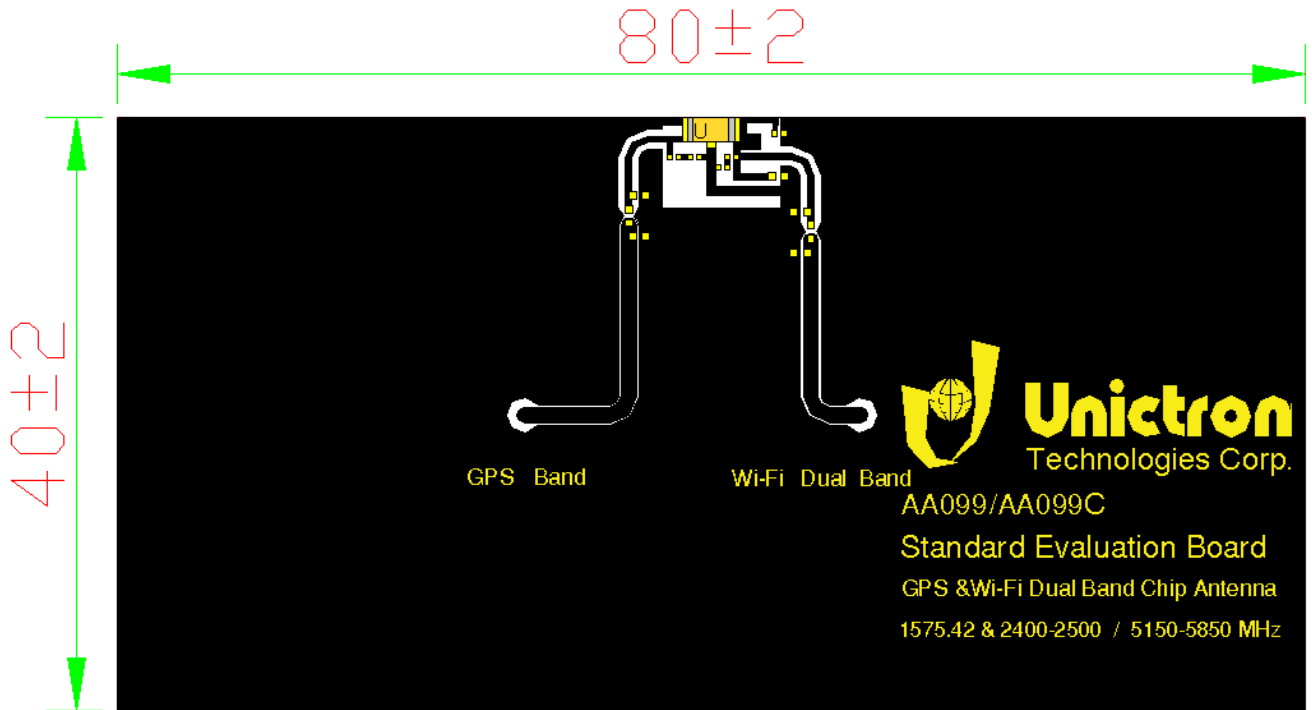

Unit : mm



詠業科技股份有限公司  
Unictron Technologies Corporation  
Website: www.unictron.com

THIS DRAWINGS AND SPECIFICATIONS ARE THE PROPERTY OF UNICTRON TECHNOLOGIES CORPORATION AND SHALL NOT BE REPRODUCED OR USED AS THE BASIS FOR THE MANUFACTURE OR SALE OF APPARATUS OR DEVICES WITHOUT PERMISSION

Prepared by : Jane

Designed by : Ken

Checked by : Mike

Approved by : Herbert

TITLE : 3.2 x 1.6 x 0.5 (mm) GPS & WiFi Dual Band Triple PCB Substrate Antenna (EVB+AA099) Engineering Specification	DOCUMENT NO.	H2B1AG1A2L0200	REV.
			B



# 7. Radiation Pattern (with 80 x 40 mm<sup>2</sup> Evaluation Board)

## 7-1. GPS Band

7-1-1. 3D Gain Pattern @ 1575.42 MHz (unit: dBi)

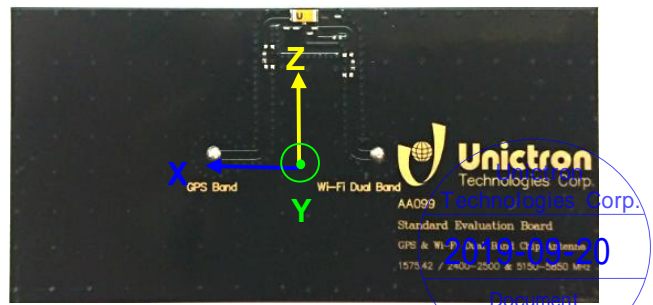
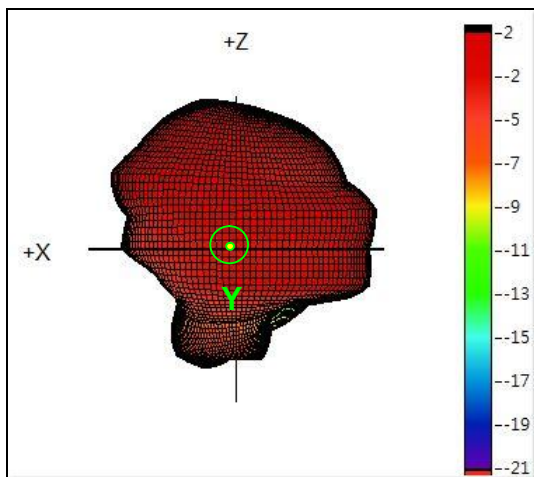
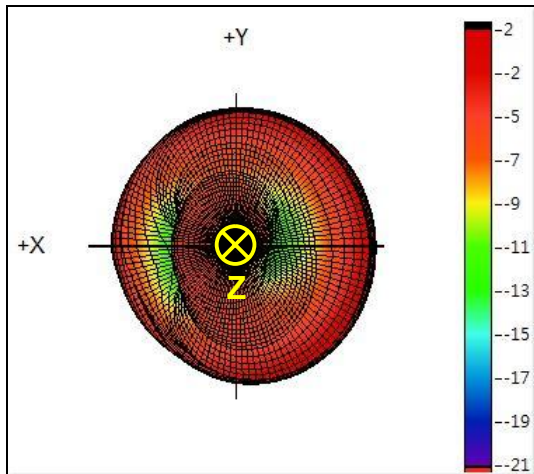
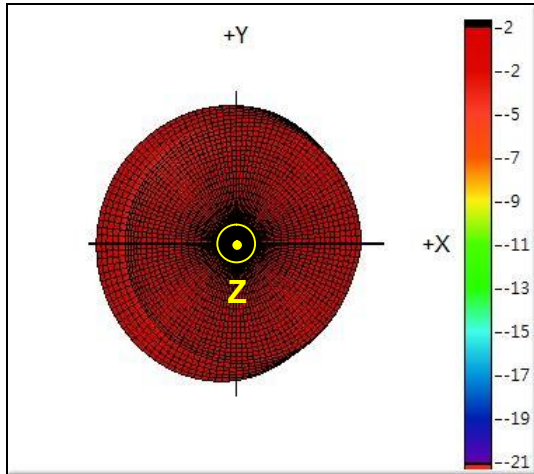

詠業科技股份有限公司  
Unictron Technologies Corporation  
Website: www.unictron.com

THIS DRAWINGS AND SPECIFICATIONS ARE THE PROPERTY OF UNICTRON TECHNOLOGIES CORPORATION AND SHALL NOT BE REPRODUCED OR USED AS THE BASIS FOR THE MANUFACTURE OR SALE OF APPARATUS OR DEVICES WITHOUT PERMISSION

Prepared by : Jane

Designed by : Ken

Checked by : Mike

Approved by : Herbert

TITLE : 3.2 x 1.6 x 0.5 (mm) GPS & WiFi Dual Band Triple PCB Substrate Antenna (EVb+AA099) Engineering Specification

DOCUMENT NO.

H2B1AG1A2L0200

REV. B



7-1-2. 3D Efficiency Table

Frequency(MHz)	1570	1571	1572	1573	1574	1575	1576	1577	1578	1579	1580
Efficiency(dB)	-2.2	-2.2	-2.1	-2.1	-2.1	-2.1	-2.1	-2.1	-2.1	-2.1	-2.1
Efficiency(%)	60.5	60.9	61.5	61.7	61.8	61.9	62.2	62.2	61.9	61.5	61.5
Peak Gain(dBi)	1.3	1.3	1.4	1.4	1.4	1.5	1.5	1.5	1.5	1.4	1.4

7-1-3. 3D Efficiency vs. Frequency

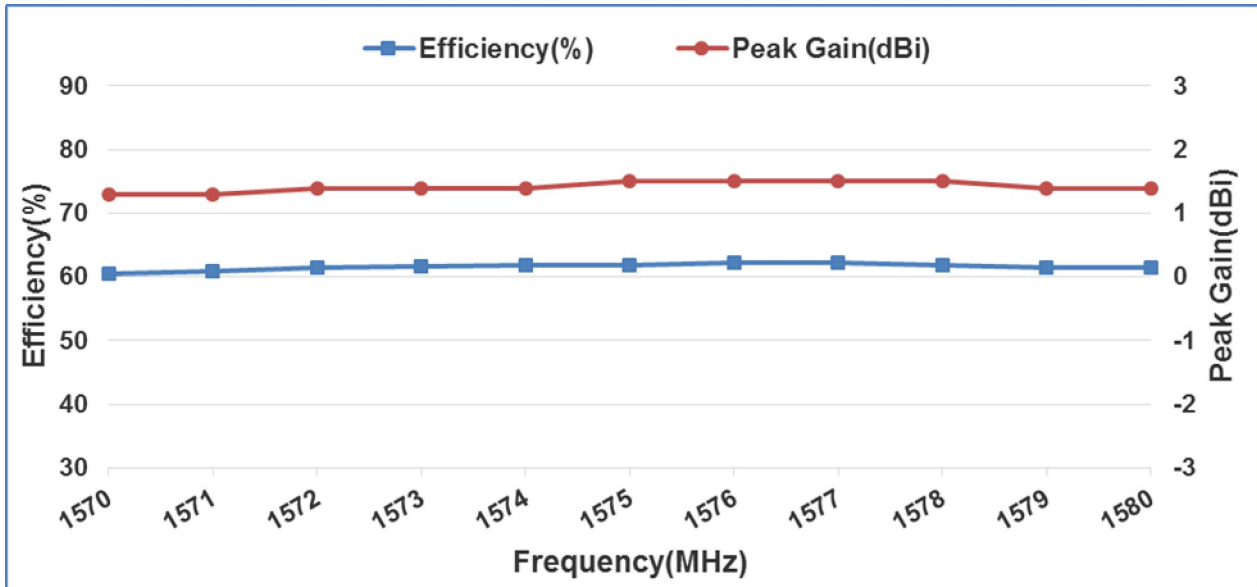

詠業科技股份有限公司  
 Unictron Technologies Corporation  
 Website: www.unictron.com

THIS DRAWINGS AND SPECIFICATIONS ARE THE PROPERTY OF UNICTRON TECHNOLOGIES CORPORATION AND SHALL NOT BE REPRODUCED OR USED AS THE BASIS FOR THE MANUFACTURE OR SALE OF APPARATUS OR DEVICES WITHOUT PERMISSION

Prepared by : Jane      Designed by : Ken      Checked by : Mike      Approved by : Herbert

TITLE : 3.2 x 1.6 x 0.5 (mm) GPS & WiFi Dual Band Triple PCB Substrate Antenna (EVB+AA099) Engineering Specification	DOCUMENT NO.	H2B1AG1A2L0200	REV.
			B

## 7-2. WiFi Band (2400~2500 MHz)

### 7-2-1. 3D Gain Pattern @ 2442 MHz (unit: dBi)

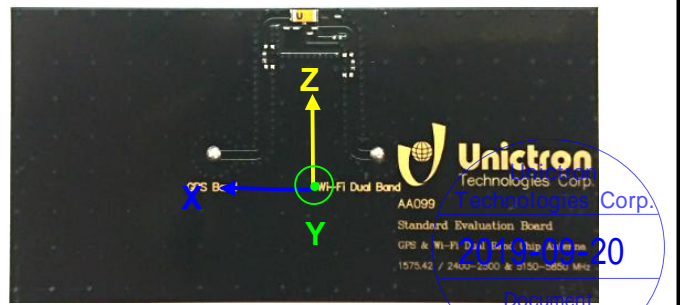
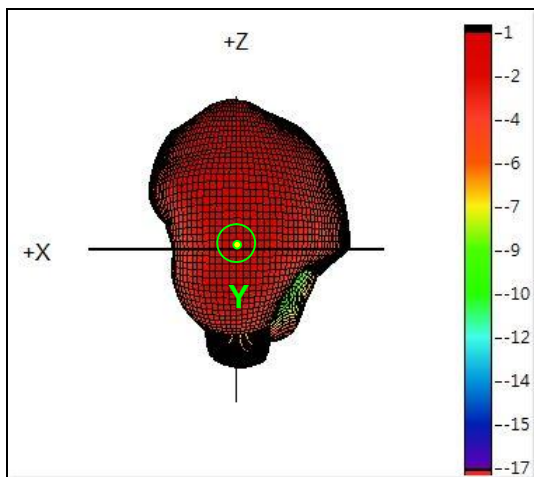
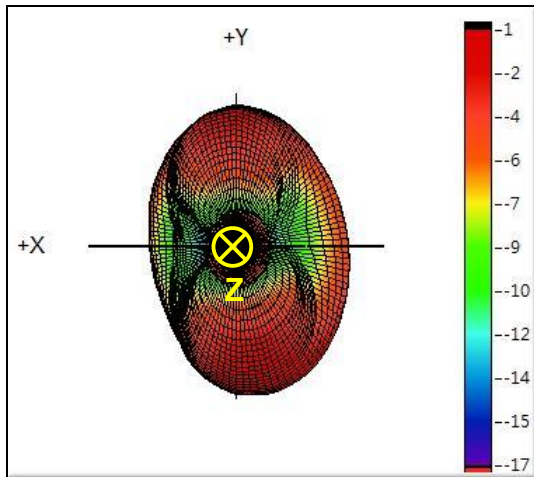
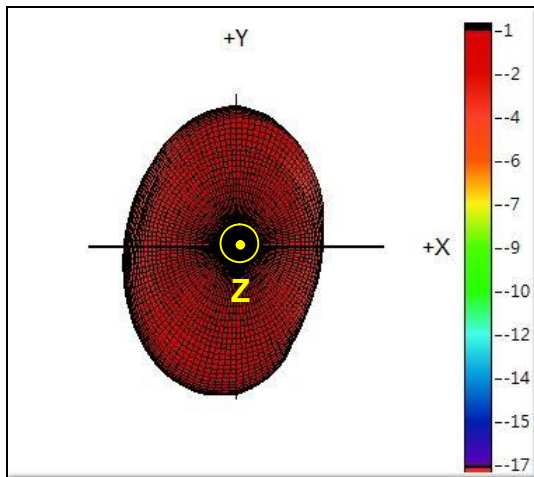

詠業科技股份有限公司  
Unictron Technologies Corporation  
Website: www.unictron.com

THIS DRAWINGS AND SPECIFICATIONS ARE THE PROPERTY OF UNICTRON TECHNOLOGIES CORPORATION AND SHALL NOT BE REPRODUCED OR USED AS THE BASIS FOR THE MANUFACTURE OR SALE OF APPARATUS OR DEVICES WITHOUT PERMISSION

Prepared by : Jane

Designed by : Ken

Checked by : Mike

Approved by : Herbert

**TITLE :** 3.2 x 1.6 x 0.5 (mm) GPS & WiFi Dual Band Triple PCB Substrate Antenna (EVb+AA099) Engineering Specification

**DOCUMENT NO.**

**H2B1AG1A2L0200**

**REV. B**

### 7-2-2. 3D Efficiency Table

Frequency(MHz)	2400	2412	2417	2422	2427	2432	2437	2442	2447	2452	2457	2462	2467	2472	2484	2500
Efficiency(dB)	-3.9	-3.8	-3.6	-3.4	-3.4	-3.1	-3.1	-3.0	-2.9	-2.8	-2.8	-2.7	-2.7	-2.7	-2.8	-3.0
Efficiency(%)	40.8	41.5	44.1	45.2	46.2	48.5	49.3	50.5	50.7	51.9	52.7	53.2	54.2	53.9	52.2	50.1
Peak Gain(dBi)	0.0	0.0	0.1	0.3	0.2	0.5	0.4	0.4	0.5	0.6	0.6	0.8	0.9	0.9	0.8	0.7

### 7-2-3. 3D Efficiency vs. Frequency

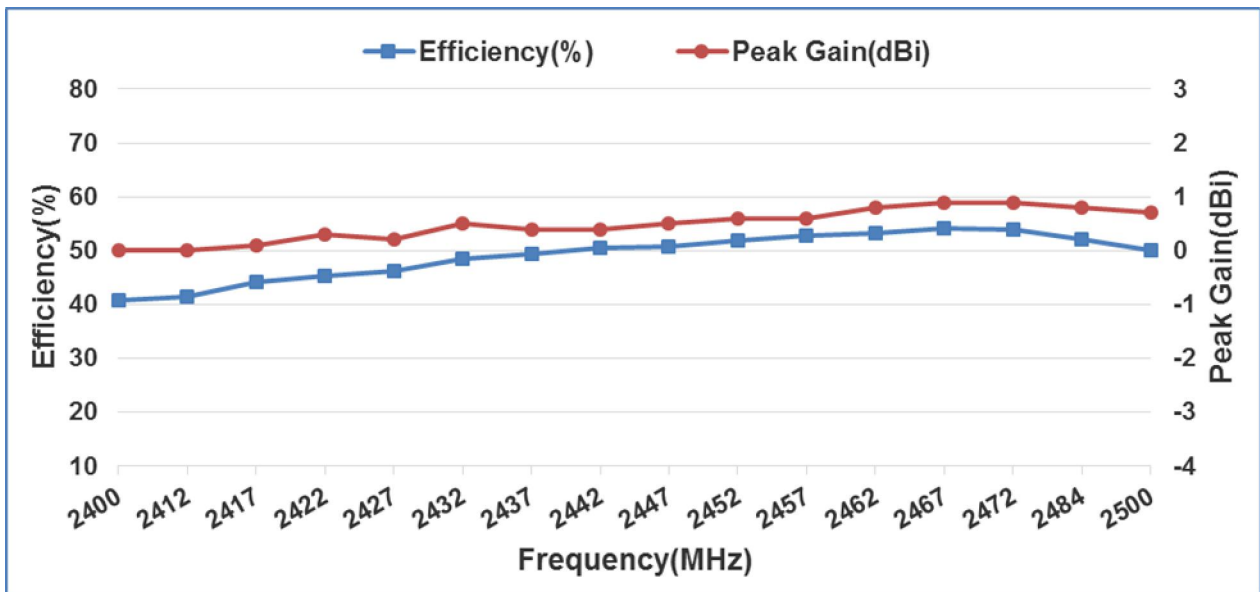

Unictron  
Technologies Corp.  
**2019-09-20**  
Document  
Control Center



**詠業科技股份有限公司**  
Unictron Technologies Corporation  
Website: www.unictron.com

THIS DRAWINGS AND SPECIFICATIONS ARE THE PROPERTY OF UNICTRON TECHNOLOGIES CORPORATION AND SHALL NOT BE REPRODUCED OR USED AS THE BASIS FOR THE MANUFACTURE OR SALE OF APPARATUS OR DEVICES WITHOUT PERMISSION

Prepared by : **Jane**

Designed by : **Ken**

Checked by : **Mike**

Approved by : **Herbert**

**TITLE** : 3.2 x 1.6 x 0.5 (mm) GPS & WiFi Dual Band Triple PCB Substrate Antenna (EVb+AA099) Engineering Specification

**DOCUMENT NO.**

**H2B1AG1A2L0200**

**REV. B**

### 7-3. WiFi Band (5150~5850 MHz)

#### 7-3-1. 3D Gain Pattern @ 5150 MHz (unit: dBi)

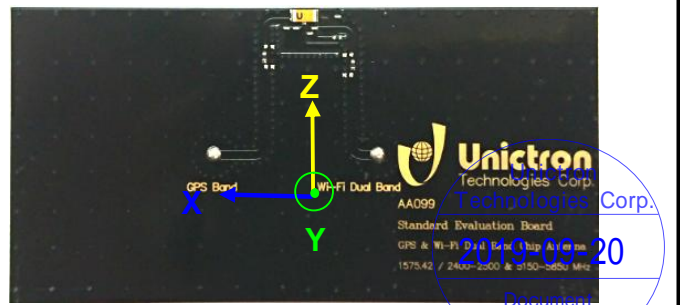
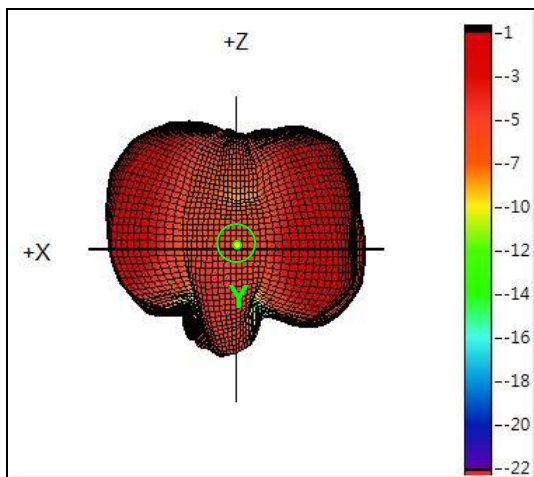
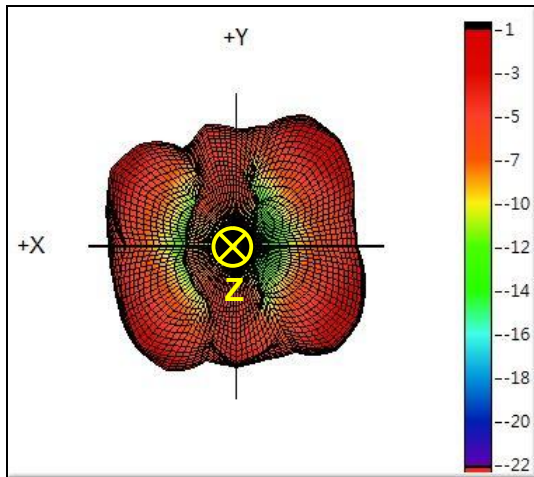
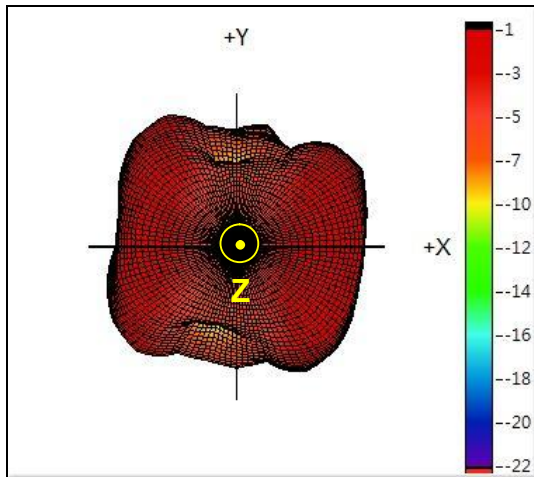

詠業科技股份有限公司  
Unictron Technologies Corporation  
Website: www.unictron.com

THIS DRAWINGS AND SPECIFICATIONS ARE THE PROPERTY OF UNICTRON TECHNOLOGIES CORPORATION AND SHALL NOT BE REPRODUCED OR USED AS THE BASIS FOR THE MANUFACTURE OR SALE OF APPARATUS OR DEVICES WITHOUT PERMISSION

Prepared by : Jane

Designed by : Ken

Checked by : Mike

Approved by : Herbert

**TITLE :** 3.2 x 1.6 x 0.5 (mm) GPS & WiFi Dual Band Triple PCB Substrate Antenna (EVb+AA099) Engineering Specification

**DOCUMENT NO.**

**H2B1AG1A2L0200**

**REV. B**

7-3-2. 3D Gain Pattern @ 5550 MHz (unit: dBi)

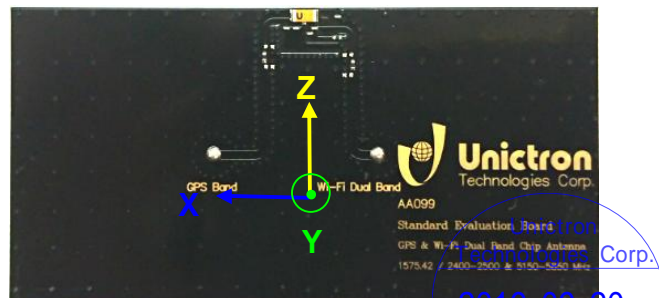
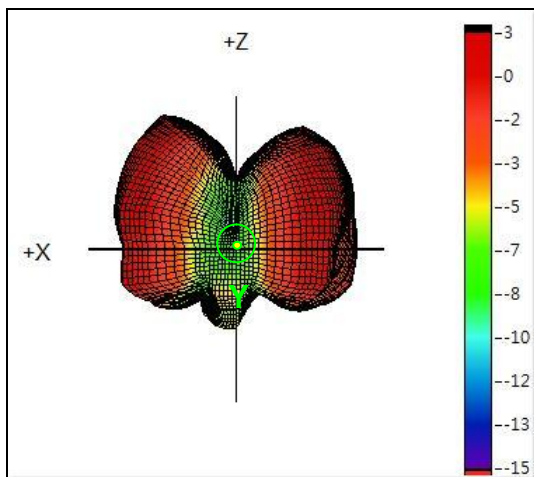
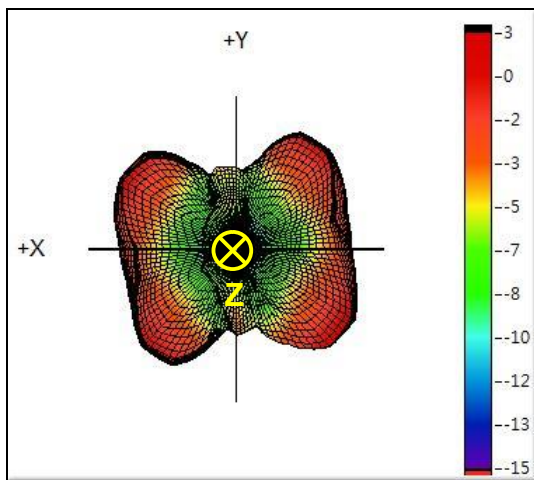
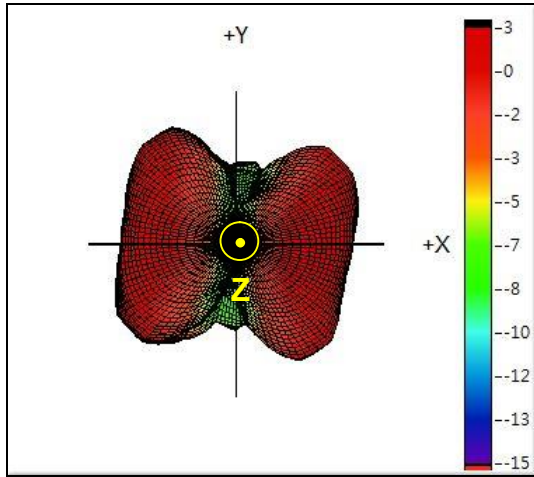

2019-09-20  
Document  
Control Center



詠業科技股份有限公司  
Unictron Technologies Corporation  
Website: www.unictron.com

THIS DRAWINGS AND SPECIFICATIONS ARE THE PROPERTY OF UNICTRON TECHNOLOGIES CORPORATION AND SHALL NOT BE REPRODUCED OR USED AS THE BASIS FOR THE MANUFACTURE OR SALE OF APPARATUS OR DEVICES WITHOUT PERMISSION

Prepared by : Jane

Designed by : Ken

Checked by : Mike

Approved by : Herbert

**TITLE :** 3.2 x 1.6 x 0.5 (mm) GPS & WiFi Dual Band Triple PCB Substrate Antenna (EVb+AA099) Engineering Specification

**DOCUMENT NO.**

**H2B1AG1A2L0200**

**REV. B**



7-3-3. 3D Gain Pattern @ 5850 MHz (unit: dBi)

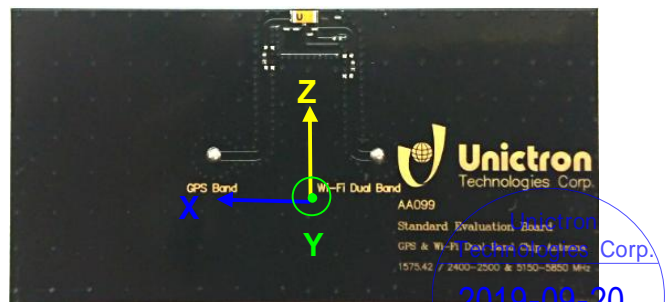
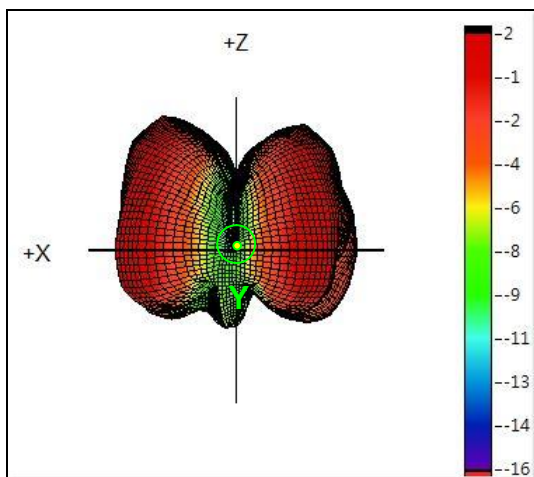
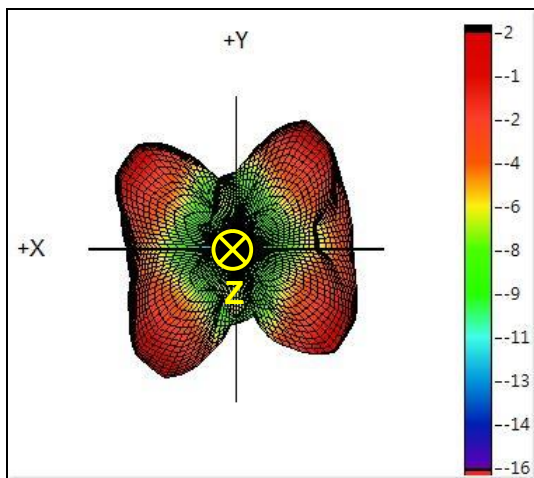
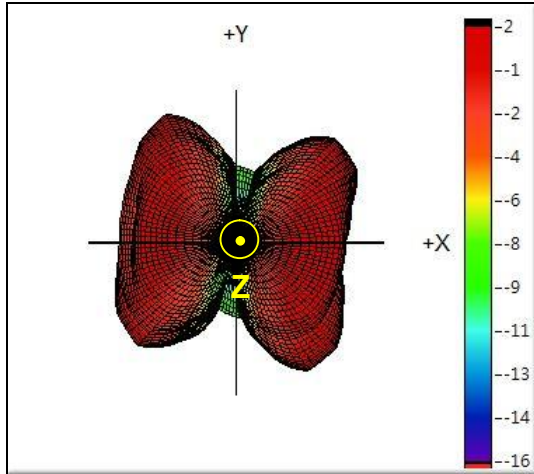

詠業科技股份有限公司  
Unictron Technologies Corporation  
Website: www.unictron.com

THIS DRAWINGS AND SPECIFICATIONS ARE THE PROPERTY OF UNICTRON TECHNOLOGIES CORPORATION AND SHALL NOT BE REPRODUCED OR USED AS THE BASIS FOR THE MANUFACTURE OR SALE OF APPARATUS OR DEVICES WITHOUT PERMISSION

Prepared by : Jane

Designed by : Ken

Checked by : Mike

Approved by : Herbert

**TITLE :** 3.2 x 1.6 x 0.5 (mm) GPS & WiFi Dual Band Triple PCB Substrate Antenna (EVb+AA099) Engineering Specification

**DOCUMENT NO.**

**H2B1AG1A2L0200**

**REV. B**

### 7-3-4. 3D Efficiency Table

Frequency(MHz)	5150	5200	5250	5300	5350	5400	5450	5500	5550	5600	5650	5700	5750	5800	5850
Efficiency(dB)	-3.3	-2.6	-2.6	-2.3	-2.4	-2.1	-1.7	-2.1	-2.0	-2.0	-2.2	-1.8	-2.2	-2.0	-2.8
Efficiency(%)	46.3	54.8	54.9	58.7	57.9	62.2	67.3	61.6	62.6	63.7	59.8	65.6	59.6	63.7	52.7
Peak Gain(dBi)	0.2	1.0	1.2	1.6	1.3	1.5	1.7	1.7	2.3	2.2	1.8	2.2	1.6	2.2	1.4

### 7-3-5. 3D Efficiency vs. Frequency

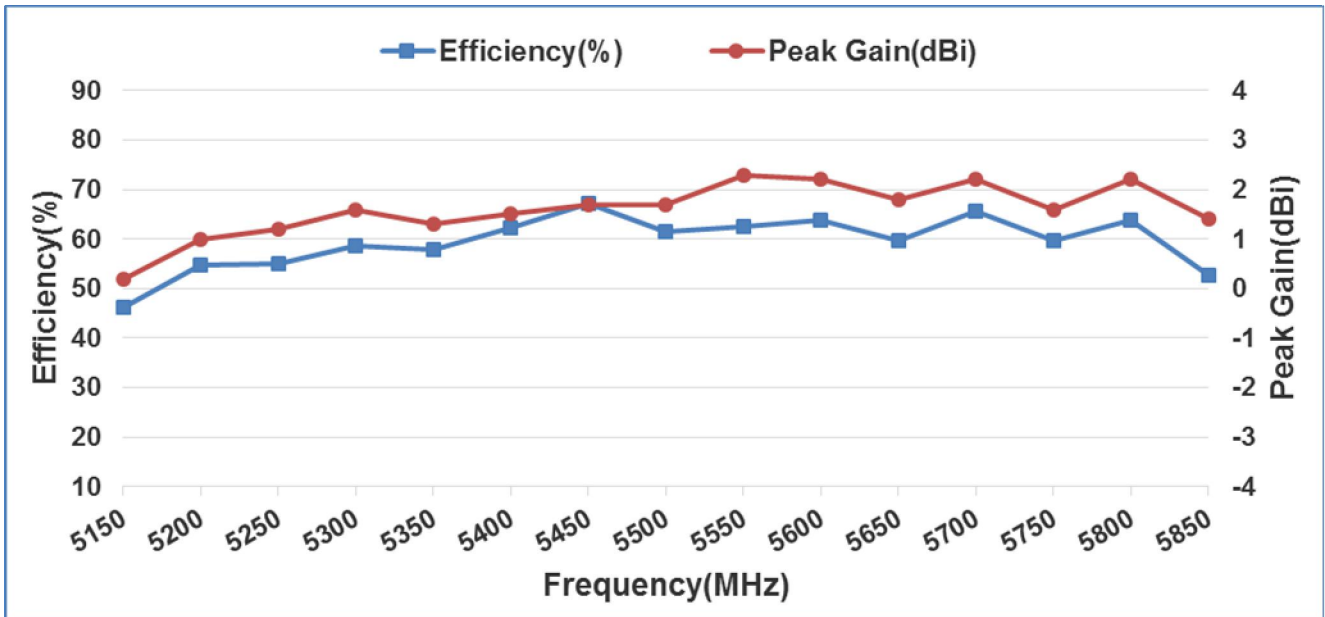

Unictron  
Technologies Corp.  
**2019-09-20**  
Document  
Control Center



**詠業科技股份有限公司**  
Unictron Technologies Corporation  
Website: www.unictron.com

THIS DRAWINGS AND SPECIFICATIONS ARE THE PROPERTY OF UNICTRON TECHNOLOGIES CORPORATION AND SHALL NOT BE REPRODUCED OR USED AS THE BASIS FOR THE MANUFACTURE OR SALE OF APPARATUS OR DEVICES WITHOUT PERMISSION

Prepared by : **Jane**

Designed by : **Ken**

Checked by : **Mike**

Approved by : **Herbert**

**TITLE** : 3.2 x 1.6 x 0.5 (mm) GPS & WiFi Dual Band Triple PCB Substrate Antenna (EVb+AA099) Engineering Specification

**DOCUMENT NO.**

**H2B1AG1A2L0200**

**REV. B**



## 8. Frequency tuning and Matching circuit

8-1. Chip antenna tuning scenario :

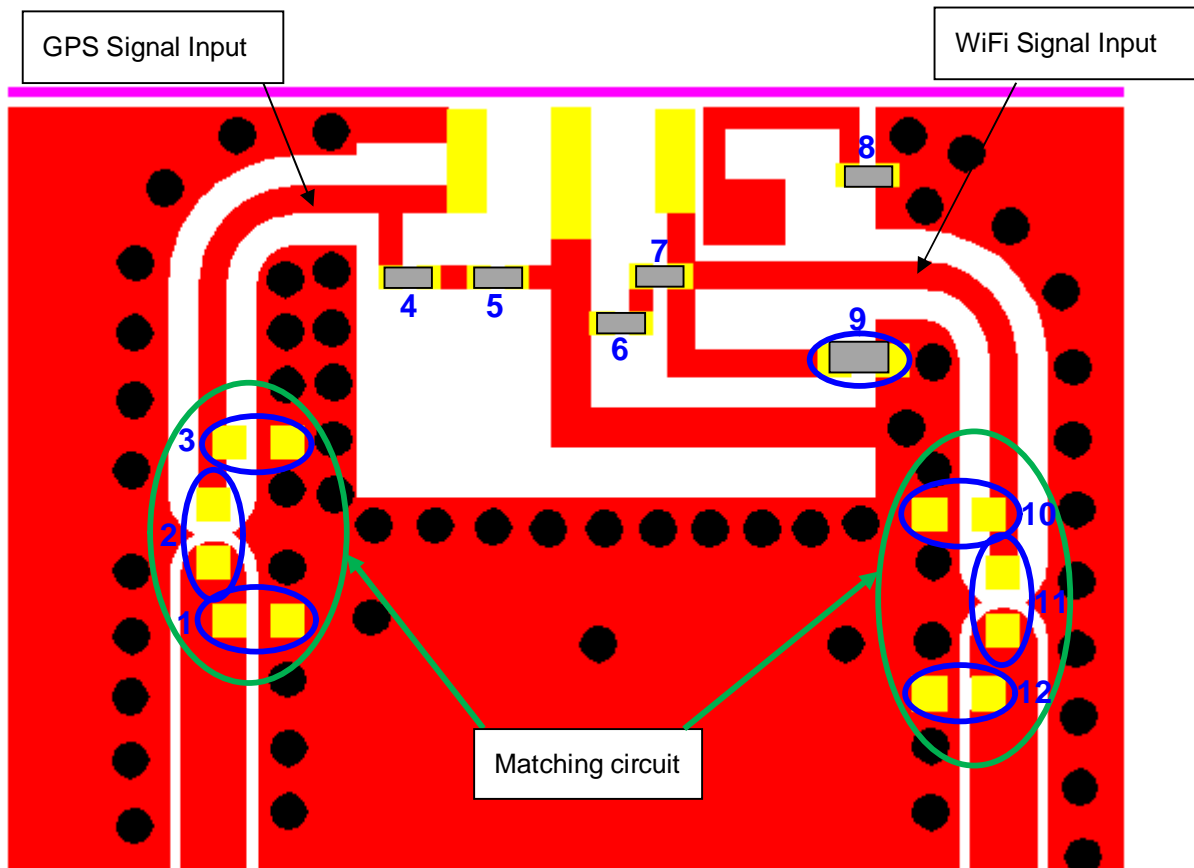

Unictron  
Technologies Corp.  
2019-09-20  
Document  
Control Center



詠業科技股份有限公司  
Unictron Technologies Corporation  
Website: www.unictron.com

THIS DRAWINGS AND SPECIFICATIONS ARE THE PROPERTY OF UNICTRON TECHNOLOGIES CORPORATION AND SHALL NOT BE REPRODUCED OR USED AS THE BASIS FOR THE MANUFACTURE OR SALE OF APPARATUS OR DEVICES WITHOUT PERMISSION

Prepared by : Jane

Designed by : Ken

Checked by : Mike

Approved by : Herbert

**TITLE :** 3.2 x 1.6 x 0.5 (mm) GPS & WiFi Dual Band Triple PCB Substrate Antenna (EVb+AA099) Engineering Specification

**DOCUMENT NO.**

**H2B1AG1A2L0200**

**REV. B**

## 8-2. Matching circuit :

With the following recommended values of matching and tuning components, the center frequencies will be about 1575.42 MHz on GPS band and 2442 MHz for  $F_L$  & 5550 MHz for  $F_H$  on WiFi band at our standard 80x40 mm<sup>2</sup> evaluation board. However, these are typical reference values which may need to be changed when circuit boards or part vendors are different.

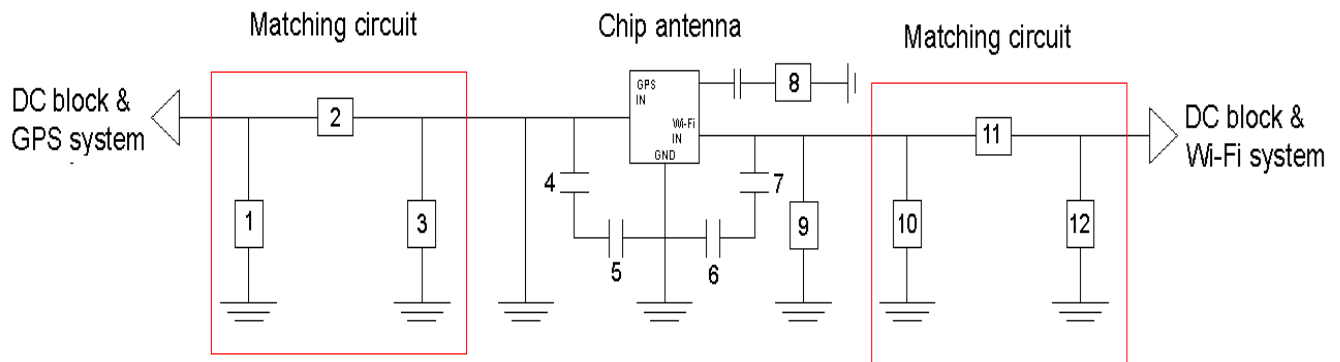

System Matching Circuit Component			
Location	Description	Vendor	Tolerance
1	N/A*		
2	0Ω, (0402)	-	±5%
3	N/A*		
4	Fine tuning element 1.8pF, (0201)	MURATA	±0.05pF
5	Fine tuning element 0.8pF, (0201)	MURATA	±0.05pF
6	Fine tuning element 0.9pF, (0201)	MURATA	±0.05pF
7	Fine tuning element 0.9pF, (0201)	MURATA	±0.05pF
8	Fine tuning element 0.4pF, (0201)	MURATA	±0.05pF
9	0Ω, (0402)	-	±5%
10	N/A*		
11	0Ω, (0402)	-	±5%
12	N/A*		
DC Block	22pF, (0402)	MURATA	±5%

Unictron  
Technologies Corp.

2019-09-20

Document  
Control Center



詠業科技股份有限公司  
Unictron Technologies Corporation  
Website: www.unictron.com

THIS DRAWINGS AND SPECIFICATIONS ARE THE PROPERTY OF UNICTRON TECHNOLOGIES CORPORATION AND SHALL NOT BE REPRODUCED OR USED AS THE BASIS FOR THE MANUFACTURE OR SALE OF APPARATUS OR DEVICES WITHOUT PERMISSION

Prepared by : Jane

Designed by : Ken

Checked by : Mike

Approved by : Herbert

**TITLE** : 3.2 x 1.6 x 0.5 (mm) GPS & WiFi Dual Band Triple PCB  
Substrate Antenna (EVb+AA099) Engineering  
Specification

**DOCUMENT**  
NO.

**H2B1AG1A2L0200**

REV.  
**B**

## 9. Soldering Conditions

### 9-1. Typical Soldering Profile for Lead-free Process

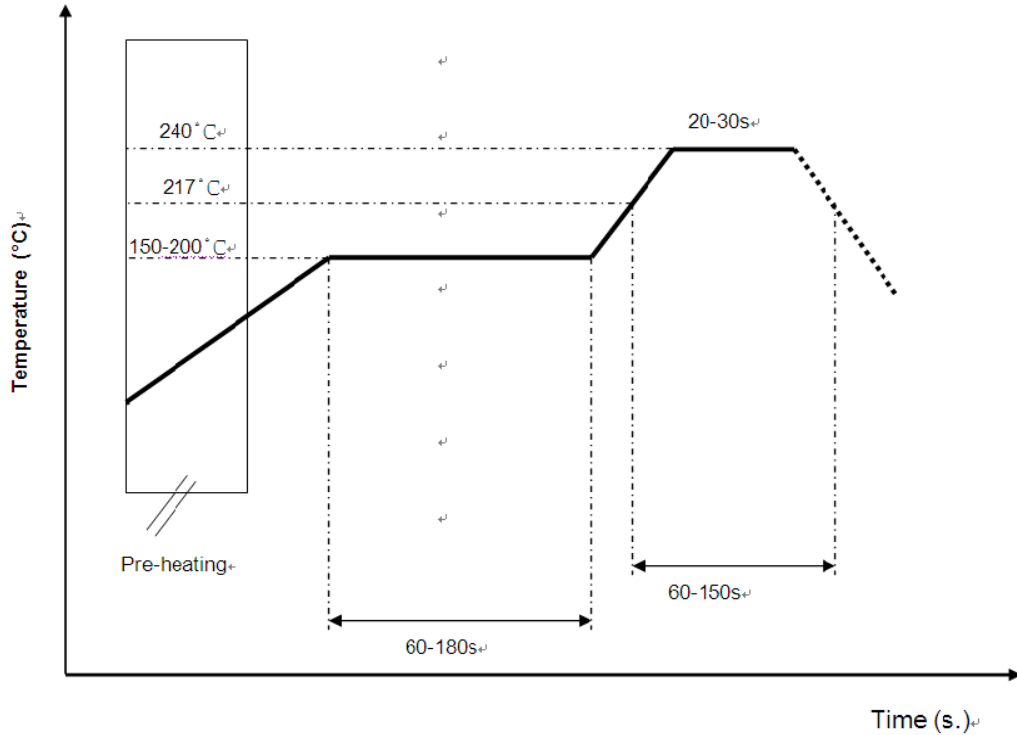

\*Recommended solder paste alloy: SAC305 (Sn96.5 /Ag3 /Cu0.5) Lead Free solder paste.

## 10. Reminders for users of Unictron's AA099 ceramic chip antennas

- 10-1. This chip antenna is made of ceramic materials which are relatively more rigid and brittle compared to circuit board materials. Furthermore, the length of this antenna is quite long. Bending of circuit board at the locations where chip antenna is mounted may cause the cracking of solder joints or antenna itself.
- 10-2. Punching/cutting of the break-off tab of PCB panel may cause severe bending of the circuit board which may result in cracking of solder joints or chip antenna itself. Therefore break-off tab shall be located away from the installation site of chip antenna.
- 10-3. Be cautious when ultrasonic welding process needs to be used near the locations where chip antennas are installed. Strong ultrasonic vibration may cause the cracking of chip antenna solder joints.



詠業科技股份有限公司  
Unictron Technologies Corporation  
Website: www.unictron.com

THIS DRAWINGS AND SPECIFICATIONS ARE THE PROPERTY OF UNICTRON TECHNOLOGIES CORPORATION AND SHALL NOT BE REPRODUCED OR USED AS THE BASIS FOR THE MANUFACTURE OR SALE OF APPARATUS OR DEVICES WITHOUT PERMISSION

Prepared by : Jane

Designed by : Ken

Checked by : Mike

Approved by : Herbert

**TITLE :** 3.2 x 1.6 x 0.5 (mm) GPS & WiFi Dual Band Triple PCB Substrate Antenna (EVb+AA099) Engineering Specification

**DOCUMENT NO.**

**H2B1AG1A2L0200**

**REV. B**

## 11. Operating & Storage Conditions

### 11-1. Operating

- (1) Maximum Input Power: 2 W
- (2) Operating Temperature: -40°C to 85°C

### 11-2. Storage

- (1) Storage Temperature: -5°C to 40°C
- (2) Relative Humidity: 20% to 70%
- (3) Shelf Life: 1 year

## 12. Notice

### (1) Installation Guide:

Please refer to Unictron's application note "General guidelines for the installation of Unictron's chip antennas" for further information.

- (2) All specifications are subject to change without notice.



詠業科技股份有限公司  
Unictron Technologies Corporation  
Website: www.unictron.com

THIS DRAWINGS AND SPECIFICATIONS ARE THE PROPERTY OF UNICTRON TECHNOLOGIES CORPORATION AND SHALL NOT BE REPRODUCED OR USED AS THE BASIS FOR THE MANUFACTURE OR SALE OF APPARATUS OR DEVICES WITHOUT PERMISSION

Prepared by : **Jane**

Designed by : **Ken**

Checked by : **Mike**

Approved by : **Herbert**

**TITLE** : 3.2 x 1.6 x 0.5 (mm) GPS & WiFi Dual Band Triple PCB Substrate Antenna (EVB+AA099) Engineering Specification

**DOCUMENT NO.**

**H2B1AG1A2L0200**

**REV. B**