

| SPECIFICATIONS | | |
|---|-------------|-------|
| PARAMETERS | VALUES | UNITS |
| RATED INPUT POWER | 1 | W |
| MAX INPUT POWER | 2 | W |
| IMPEDANCE | 8 ± 15% | OHM |
| OUTPUT SPL @ 1W/1M (AT 1.0, 1.2, 1.5, 2.0 kHz) | 84 ± 3 | dB(A) |
| DISTORTION (MAX.) | 5% | - |
| RESONANT FREQUENCY | 450 ± 20% | Hz |
| FREQUENCY RANGE | 450 ~ 20000 | Hz |
| HOUSING MATERIAL | ABS | - |
| CONE MATERIAL | PAPER | - |
| MAGNET MATERIAL | Nd-Fe-B | - |
| OPERATING TEMPERATURE | -20 ~ +60 | °C |
| WEIGHT | 13 | grams |

THIS DOCUMENT CONTAINS DATA PROPRIETARY TO PROJECTS UNLIMITED, INC. ANY USE OR REPRODUCTION, IN ANY FORM, WITHOUT PRIOR WRITTEN PERMISSION OF PROJECTS UNLIMITED, INC. IS PROHIBITED.
©2003, Projects Unlimited Inc.

| REVISION HISTORY | | | |
|------------------|--|-----------|----------|
| LTR | DESCRIPTION | DATE | APPROVED |
| - | RELEASED FROM ENGINEERING | 6/29/2006 | |
| A | REVISED CONE MATERIAL | 3/16/2007 | R.W. |
| B | REVISED TO INVENTOR 3-D DRAWING TEMPLATE | 5/19/2008 | B.R. |

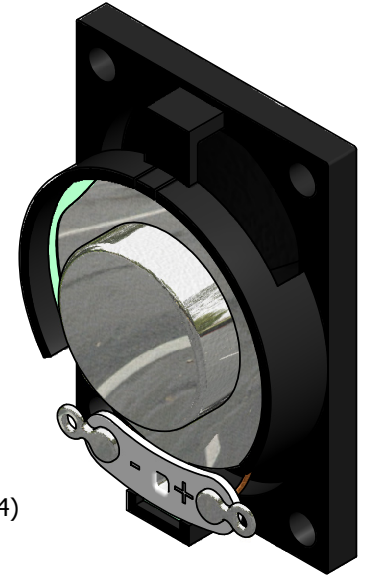
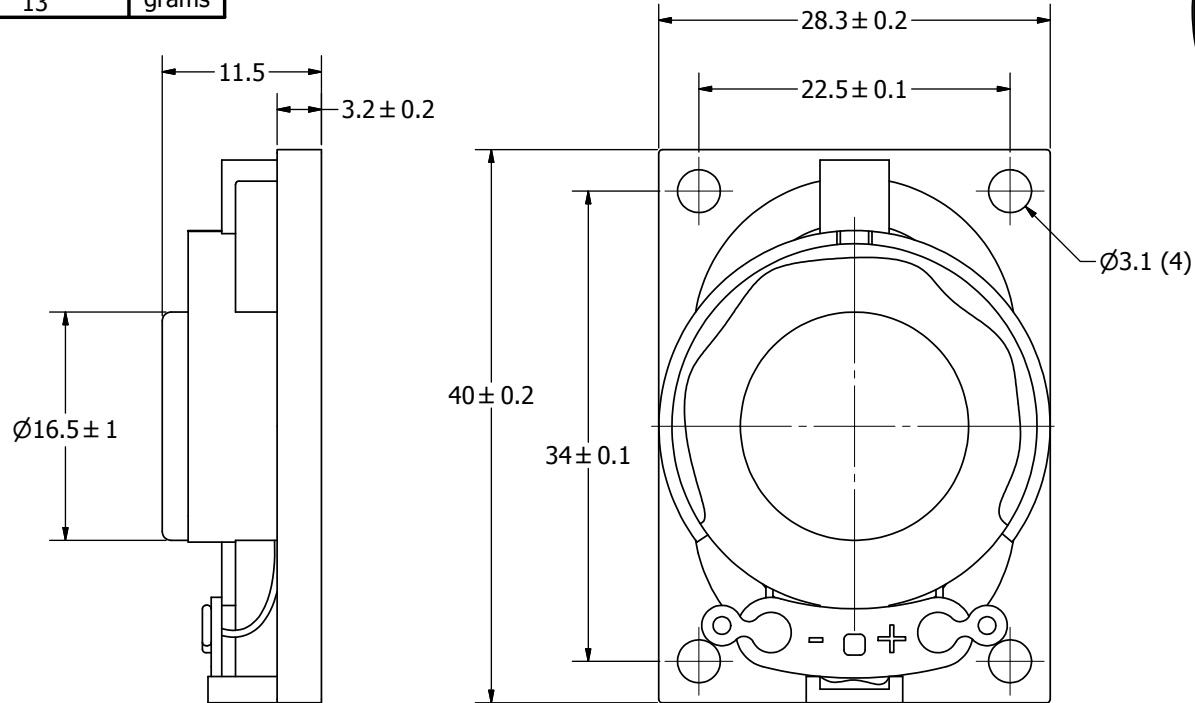

NOTES:

1. ALL DIMENSIONS ARE IN MILLIMETERS.
2. SPECIFICATIONS SUBJECT TO CHANGE OR WITHDRAWAL WITHOUT NOTICE.
3. THIS PART IS RoHS 2002/95/EC COMPLIANT.

| | | | | | | | | |
|--|-------------------|-------------|-----------|------------|-----------|------------------|-----------|------------|
| UNLESS OTHERWISE SPECIFIED: DIMENSIONS ARE IN MILLIMETERS, TOLERANCES ARE ±0.5 AND ANGLES ARE ±3°. | SIZE A3 | Designed by | Date | Checked by | Date | Approved by | Date | Drawn Date |
| | | J.D. | 6/28/2006 | E.P. | 6/28/2006 | B.R. | 6/28/2006 | 5/19/2008 |
| AS04008PO-2-R.idw | | | | | | AS04008PO-2-WR-R | | |
| | | | | | | Speaker | | |
| | | | | | - | 1 / 1 | | |