

TPS65023x 电源管理 IC (PMIC), 具有 3 个直流/直流转换器、3 个 LDO、I²C 接口和 DVS

1 特性

- 适用于处理器内核的 90% 效率的 1.7A 降压转换器 (VDCDC1)
- 用于系统电压的 95% 效率的 1.2A 降压转换器 (VDCDC2)
- 用于存储器电压的 92% 效率的 1.0A 降压转换器 (VDCDC3)
- 用于支持实时时钟 (VRTC) 的 30mA LDO 和开关
- 2 个 200mA 通用 LDO
- 用于处理器内核的动态电压管理
- 可使用两个数字输入引脚进行 LDO 电压预选
- 外部可调复位延迟时间
- 电池备用功能
- 用于电感转换器的单独使能引脚
- 兼容 I²C 的串行接口
- 在特性列表中增加了兼容 I²C™ 设置和保持计时:
 - TPS65023: 300ns
 - TPS65023B: 100ns
- 85μA 静态电流
- 低波纹 PFM 模式
- 热关断保护
- 40 引脚 5mm x 5mm WQFN 封装

2 应用

- 数字媒体播放器
- 互联网音频播放器
- 数码相机
- 智能手机
- 电源 DaVinci™ DSP 系列解决方案

3 说明

TPS65023x 器件是一种集成式电源管理 IC, 适用于由一节

锂离子或锂离子聚合物电池供电并需要多个电源轨的应用。TPS65023x 器件具有三个高效的降压转换器, 用于在基于处理器的系统中提供内核电压、外设、I/O 以及存储器电源轨。内核转换器可通过串行接口实现动态电压变化, 从而使系统实现动态节能。这三个降压转换器会在轻负载时进入低功耗模式, 从而在可能的最宽负载电流范围内实现最高效率。

TPS65023x 还集成了两个可通过外部输入引脚启用的通用 200mA LDO 稳压器。每个 LDO 可在 1.5V 至 6.5V 输入电压范围内正常运行, 从而使得它们可以由其中一个降压转换器供电, 也可以由电池直接供电。用户可使用 DEFLDO1 和 DEFLDO2 引脚通过数字方式将这两个 LDO 的默认输出电压设置为四个不同的电压组合。串行接口可用于动态电压调节和屏蔽中断, 或用于停用、启用和设置 LDO 输出电压。该接口符合快速模式和标准模式 I²C 规格, 可实现高达 400kHz 的传输频率。TPS65023x 采用 40 引脚 WQFN 封装, 并在 -40°C 至 85°C 的自然通风温度范围内运行。

器件信息(1)

器件型号	封装	封装尺寸 (标称值)
TPS65023	WQFN (40)	5.00mm x 5.00mm
TPS65023B		

(1) 如需了解所有可用封装, 请参阅产品说明书末尾的可订购产品附录。

简化原理图

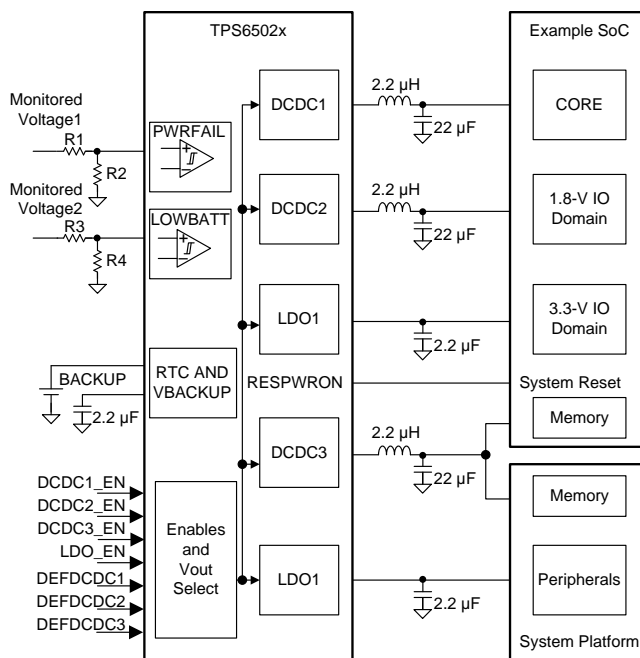

目录

1	特性	1	7.1	Overview	21
2	应用	1	7.2	Functional Block Diagram	22
3	说明	1	7.3	Feature Description	22
4	修订历史记录	2	7.4	Device Functional Modes	27
5	Pin Configuration and Functions	5	7.5	Programming	28
6	Specifications	7	7.6	Register Maps	31
6.1	Absolute Maximum Ratings	7	8	Application and Implementation	37
6.2	ESD Ratings	7	8.1	Application Information	37
6.3	Recommended Operating Conditions	7	8.2	Typical Application	39
6.4	Thermal Information	8	9	Power Supply Recommendations	44
6.5	Electrical Characteristics	8	9.1	Requirements for Supply Voltages Below 3.0 V	44
6.6	Electrical Characteristics: Supply Pins VCC, VINDCDC1, VINDCDC2, VINDCDC3	10	10	Layout	45
6.7	Electrical Characteristics: Supply Pins VBACKUP, VSYSIN, VRTC, VINLDO	10	10.1	Layout Guidelines	45
6.8	Electrical Characteristics: VDCDC1 Step-Down Converter	11	10.2	Layout Example	45
6.9	Electrical Characteristics: VDCDC2 Step-Down Converter	12	11	器件和文档支持	46
6.10	Electrical Characteristics: VDCDC3 Step-Down Converter	12	11.1	器件支持	46
6.11	I ² C Timing Requirements for TPS65023B	13	11.2	文档支持	46
6.12	Typical Characteristics	16	11.3	相关链接	46
7	Detailed Description	21	11.4	社区资源	46
			11.5	商标	46
			11.6	静电放电警告	47
			11.7	术语表	47
			12	机械、封装和可订购信息	47

4 修订历史记录

注：之前版本的页码可能与当前版本有所不同。

Changes from Revision K (December 2015) to Revision L	Page
• 已更改 更改了数据表的标题	1
• Replaced references of TI PowerPAD IC package with thermal pad	6
• 已添加 增加了 器件支持 和 文档支持 部分	46
• 已更改 静电放电注意事项 声明	46

Changes from Revision J (September 2011) to Revision K	Page
• 已添加 添加了 ESD 额定值表、特性说明部分、器件功能模式、应用和实施部分、电源相关建议部分、布局部分、器件和文档支持部分以及机械、封装和可订购信息部分	1

Changes from Revision I (July 2010) to Revision J	Page
• Added Thermal Information Table and deleted Dissipation Ratings Table	8

Changes from Revision H (December 2009) to Revision I	Page
• 已添加 I ² C 的 串行 接口	1
• 已添加 TPS65023B 器件规格	1
• 添加了 TPS65023B 器件的订购信息。	1
• Added specs for TPS65023B device	8
• Changed "VBACKUP threshold" test condition typographical error from "VBACKUP falling" to "VBACKUP rising"	11
• Added specs for TPS65023B device	13

• Added Differences table for TPS65023 and TPS65023B devices	39
--	----

Changes from Revision G (October 2008) to Revision H	Page
---	-------------

• Changed $I_{O(DCDC1)}$ MAX from: 1500 mA to: 1700 mA	7
• Added High level input voltage for the SDAT pin	8
• Changed I_O from: 1500 mA MIN to 1700 mA	11
• Changed I_O maximum from: 1.5 A to: 1.7 A for VDCDC1 fixed and adjustable output voltage test condition specs.	11
• Changed I_O maximum from: 1500 mA to: 1700 mA for VDCDC1 Load Regulation test condition	11
• Changed VDCDC1 "soft-start ramp time" spec to: " t_{Start} and t_{Ramp} " specifications with MIN TYP MAX values.	11
• Changed VDCDC2 "soft-start ramp time" spec To: " t_{Start} and t_{Ramp} " specifications with MIN TYP MAX values.	12
• Changed VDCDC3 "soft-start ramp time" spec To: " t_{Start} and t_{Ramp} " specifications with MIN TYP MAX values.	13
• Changed FBD graphic to show 1700 mA for DCDC1 Buck Converter	22
• Changed text string from: "1.2 V or 1.8 V" to: "1.2 V to 1.6 V" in the STEP-DOWN CONVERTERS.,VDCDC1.... description.	24
• Changed graphic entity to the one used in the Application Note SLVA273	39

Changes from Revision F (July 2007) to Revision G	Page
--	-------------

• Changed the Interrupt Management and the \overline{INT} Pin section.....	28
--	----

Changes from Revision E (January 2007) to Revision F	Page
---	-------------

• Changed text string from: "If it is tied to VCC, the default is 2.5 V" To: "If it is tied to VCC, the default is 3.3 V"	24
---	----

Changes from Revision D (December 2006) to Revision E	Page
--	-------------

• Changed LDO1 output voltage range from: 3.3 to: 3.3	9
• Changed text string from: "VDCDC2 converter defaults to 1.8 V or 2.5 V" to: "VDCDC2 converter defaults to 1.8 V or 3.3 V"	24

Changes from Revision C (October 2006) to Revision D	Page
---	-------------

• Changed Typical Configuration for Ti DaVinci Processors	39
---	----

Changes from Revision B (June 2006) to Revision C	Page
--	-------------

• Changed from: AD Coupled to: AD Coupled - Figure 16	17
• Changed from: AD Coupled to: AD Coupled - Figure 17	18

Changes from Revision A (June 2006) to Revision B	Page
--	-------------

• 已更改 从 97% 效率的 1.5A 降压转换器更改为 90% 效率的 1.7A 降压转换器	1
• 已更改 从 6mm x 6mm QFN 封装更改为 5mm x 5mm QFN 封装	1
• 已更改 从 RHA 封装更改为 RSB 封装.....	1
• Changed from: $I_{O(DCDC2)}$ to: $I_{O(DCDC1)}$	7
• Changed Forward current limit - removed TBD and added values	11
• Changed Fixed output voltage - removed TBD and added values	11
• Changed Fixed output voltage - removed TBD and added values	12

TPS65023, TPS65023B

ZHCSI15L – JUNE 2006 – REVISED MAY 2018

www.ti.com.cn

• Added VINDCDC3 = 3.6 V to Maximum output current	12
• Changed Fixed output voltage - removed TBD and added values	13
• Changed Figure 3 (DVS Timing)	15
• Changed Figure 11 (Graph - DCDC2: OUTPUT VOLTAGE).....	17
• Added Figure 12 (Graph - DCDC3: OUTPUT VOLTAGE).....	17
• Changed Figure 20 (Graph - VDCDC2 OUTPUT VOLTAGE RIPPLE)	18
• Added Reset Condition of DCDC1 Information	37
• Changed Typical Configuration for Ti DaVinci Processors	39
• Changed from: TPS65023 typically use a 3.3 μ H output inductor to: TPS65023 typically use a 2.2 μ H output inductor....	40
• Changed from: VDCDC3 to: VDCDC1	41
• Changed from: VDEFDCDC3 to: DEFDCDC1	41
• Changed from: 2.5 V to 3.3 V (Table 20)	41

Changes from Original (May 2006) to Revision A
Page

• Changed Electrical Characteristics: VDCDC1 Step-Down Converter	11
• Changed Electrical Characteristics: VDCDC3 Step-Down Converter	12
• Changed CON_CTRL Register Address - Column B0 default value changed from 1 to 0.....	33
• Changed VDCDC# to VDCDC1	35

5 Pin Configuration and Functions

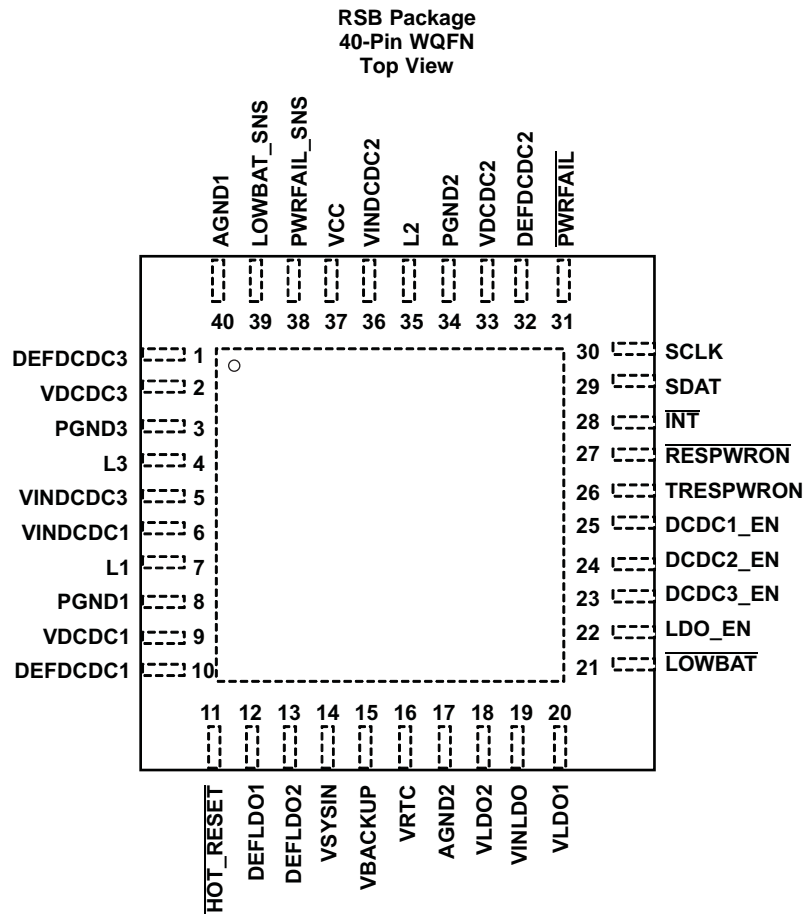

Pin Functions

PIN		I/O	DESCRIPTION
NAME	NO.		
SWITCHING REGULATOR SECTION			
AGND1	40	—	Analog ground. All analog ground pins are connected internally on the chip.
AGND2	17	—	Analog ground. All analog ground pins are connected internally on the chip.
DCDC1_EN	25	I	VDCDC1 enable pin. A logic high enables the regulator, a logic low disables the regulator.
DCDC2_EN	24	I	VDCDC2 enable pin. A logic high enables the regulator, a logic low disables the regulator.
DCDC3_EN	23	I	VDCDC3 enable pin. A logic high enables the regulator, a logic low disables the regulator.
DEFDCDC1	10	I	Input signal indicating default VDCDC1 voltage, 0 = 1.2 V, 1 = 1.6 V DEFDCDC1 can also be connected to a resistor divider between VDCDC1 and GND, if the output voltage of the DCDC1 converter is set in a range from 0.6 V to VINDCDC1 V.
DEFDCDC2	32	I	Input signal indicating default VDCDC2 voltage, 0 = 1.8 V, 1 = 3.3 V DEFDCDC2 can also be connected to a resistor divider between VDCDC2 and GND, if the output voltage of the DCDC2 converter is set in a range from 0.6 V to VINDCDC2 V.
DEFDCDC3	1	I	Input signal indicating default VDCDC3 voltage, 0 = 1.8 V, 1 = 3.3 V DEFDCDC3 can also be connected to a resistor divider between VDCDC3 and GND, if the output voltage of the DCDC3 converter is set in a range from 0.6 V to VINDCDC3 V.
L1	7	—	Switch pin of VDCDC1 converter. The VDCDC1 inductor is connected here.
L2	35	—	Switch pin of VDCDC2 converter. The VDCDC2 inductor is connected here.
L3	4	—	Switch pin of VDCDC3 converter. The VDCDC3 inductor is connected here.
PGND1	8	—	Power ground for VDCDC1 converter

Pin Functions (continued)

PIN		I/O	DESCRIPTION
NAME	NO.		
PGND2	34	—	Power ground for VDCDC2 converter
PGND3	3	—	Power ground for VDCDC3 converter
VCC	37	I	Power supply for digital and analog circuitry of VDCDC1, VDCDC2, and VDCDC3 DC-DC converters. VCC must be connected to the same voltage supply as VINDCDC3, VINDCDC1, and VINDCDC2. VCC also supplies serial interface block.
VDCDC1	9	I	VDCDC1 feedback voltage sense input. Connect directly to VDCDC1
VDCDC2	33	I	VDCDC2 feedback voltage sense input. Connect directly to VDCDC2
VDCDC3	2	I	VDCDC3 feedback voltage sense input. Connect directly to VDCDC3
VINDCDC1	6	I	Input voltage for VDCDC1 step-down converter. VINDCDC1 must be connected to the same voltage supply as VINDCDC2, VINDCDC3, and VCC.
VINDCDC2	36	I	Input voltage for VDCDC2 step-down converter. VINDCDC2 must be connected to the same voltage supply as VINDCDC1, VINDCDC3, and VCC.
VINDCDC3	5	I	Input voltage for VDCDC3 step-down converter. VINDCDC3 must be connected to the same voltage supply as VINDCDC1, VINDCDC2, and VCC.
Thermal Pad	—	—	Connect the power pad to analog ground
LDO REGULATOR SECTION			
DEFLD01	12	I	Digital input. DEFLD01 sets the default output voltage of LDO1 and LDO2.
DEFLD02	13	I	Digital input. DEFLD02 sets the default output voltage of LDO1 and LDO2.
LDO_EN	22	I	Enable input for LDO1 and LDO2. A logic high enables the LDOs and a logic low disables the LDOs.
VBACKUP	15	I	Connect the backup battery to this input pin
VINLDO	19	I	Input voltage for LDO1 and LDO2
VLDO1	20	O	Output voltage of LDO1
VLDO2	18	O	Output voltage of LDO2
VRTC	16	O	Output voltage of the LDO and switch for the real time clock
VSYSIN	14	I	Input of system voltage for VRTC switch
CONTROL AND I²C SECTION			
$\overline{\text{HOT_RESET}}$	11	I	Push button input that reboots or wakes up the processor through the $\overline{\text{RESPWRON}}$ output pin.
$\overline{\text{INT}}$	28	O	Open-drain output
$\overline{\text{LOW_BAT}}$	21	O	Open-drain output of LOW_BAT comparator
LOWBAT_SNS	39	I	Input for the comparator driving the $\overline{\text{LOW_BAT}}$ output.
$\overline{\text{PWRFAIL}}$	31	O	Open-drain output. Active low when $\overline{\text{PWRFAIL}}$ comparator indicates low VBAT condition.
PWRFAIL_SNS	38	I	Input for the comparator driving the $\overline{\text{PWRFAIL}}$ output
$\overline{\text{RESPWRON}}$	27	O	Open-drain system reset output
SCLK	30	I	Serial interface clock line
SDAT	29	I/O	Serial interface data and address
TRESPWRON	26	I	Connect the timing capacitor to TRESPWRON to set the reset delay time: 1 nF → 100 ms

6 Specifications

6.1 Absolute Maximum Ratings

over operating free-air temperature range (unless otherwise noted)⁽¹⁾

		MIN	MAX	UNIT
V _I	Input voltage on all pins except AGND and PGND pins with respect to AGND	-0.3	7	V
	Current at VINDCDC1, L1, PGND1, VINDCDC2, L2, PGND2, VINDCDC3, L3, PGND3		2000	mA
	Peak current at all other pins		1000	mA
	Continuous total power dissipation	See Thermal Information		
T _A	Operating free-air temperature	-40	85	°C
T _J	Maximum junction temperature		125	°C
T _{stg}	Storage temperature	-65	150	°C

- (1) Stresses beyond those listed under *Absolute Maximum Ratings* may cause permanent damage to the device. These are stress ratings only, which do not imply functional operation of the device at these or any other conditions beyond those indicated under *Recommended Operating Conditions*. Exposure to absolute-maximum-rated conditions for extended periods may affect device reliability.

6.2 ESD Ratings

		VALUE	UNIT
V _(ESD)	Electrostatic discharge	Human-body model (HBM), per ANSI/ESDA/JEDEC JS-001 ⁽¹⁾	±2000
		Charged-device model (CDM), per JEDEC specification JESD22-C101 ⁽²⁾	±500

- (1) JEDEC document JEP155 states that 500-V HBM allows safe manufacturing with a standard ESD control process.

- (2) JEDEC document JEP157 states that 250-V CDM allows safe manufacturing with a standard ESD control process.

6.3 Recommended Operating Conditions

over operating free-air temperature range (unless otherwise noted)

		MIN	NOM	MAX	UNIT
V _{CC}	Input voltage step-down converters (VINDCDC1, VINDCDC2, VINDCDC3); pins need to be tied to the same voltage rail	2.5		6	V
V _O	Output voltage for VDCDC1 step-down converter ⁽¹⁾	0.6		VINDCDC1	V
	Output voltage for VDCDC2 step-down converter ⁽¹⁾	0.6		VINDCDC2	
	Output voltage for VDCDC3 step-down converter ⁽¹⁾	0.6		VINDCDC3	
V _I	Input voltage for LDOs (VINLDO1, VINLDO2)	1.5		6.5	V
V _O	Output voltage for LDOs (VLDO1, VLDO2)	1		VINLDO1–2	V
I _{O(DCDC1)}	Output current at L1			1700	mA
	Inductor at L1 ⁽²⁾	1.5	2.2		
C _{I(DCDC1)}	Input capacitor at VINDCDC1 ⁽²⁾	10			μF
C _{O(DCDC1)}	Output capacitor at VDCDC1 ⁽²⁾	10	22		μF
I _{O(DCDC2)}	Output current at L2			1200	mA
	Inductor at L2 ⁽²⁾	1.5	2.2		
C _{I(DCDC2)}	Input capacitor at VINDCDC2 ⁽²⁾	10			μF
C _{O(DCDC2)}	Output capacitor at VDCDC2 ⁽²⁾	10	22		μF
I _{O(DCDC3)}	Output current at L3			1000	mA
	Inductor at L3 ⁽²⁾	1.5	2.2		
C _{I(DCDC3)}	Input capacitor at VINDCDC3 ⁽²⁾	10			μF
C _{O(DCDC3)}	Output capacitor at VDCDC3 ⁽²⁾	10	22		μF
C _{I(VCC)}	Input capacitor at VCC ⁽²⁾	1			μF
C _{I(VINLDO)}	Input capacitor at VINLDO ⁽²⁾	1			μF
C _{O(VLDO1-2)}	Output capacitor at VLDO1, VLDO2 ⁽²⁾	2.2			μF

- (1) When using an external resistor divider at DEFDCDC3, DEFDCDC2, and DEFDCDC1

- (2) See [Application Information](#) section for more information.

Recommended Operating Conditions (continued)

over operating free-air temperature range (unless otherwise noted)

		MIN	NOM	MAX	UNIT
$I_{O(VLDO1-2)}$	Output current at VLDO1, VLDO2			200	mA
$C_{O(VRTC)}$	Output capacitor at VRTC ⁽²⁾	4.7			μF
T_A	Operating ambient temperature	-40		85	°C
T_J	Operating junction temperature	-40		125	°C
	Resistor from VINDCDC3, VINDCDC2, VINDCDC1 to VCC used for filtering ⁽³⁾		1	10	Ω

(3) Up to 3 mA can flow into V_{CC} when all 3 converters are running in PWM. This resistor causes the UVLO threshold to be shifted accordingly.

6.4 Thermal Information

THERMAL METRIC ⁽¹⁾	TPS65023x		UNIT
	RSB (WQFN)		
	40 PINS		
$R_{\theta JA}$	Junction-to-ambient thermal resistance	32.7	°C/W
$R_{\theta JC(top)}$	Junction-to-case (top) thermal resistance	15.3	°C/W
$R_{\theta JB}$	Junction-to-board thermal resistance	13.6	°C/W
Ψ_{JT}	Junction-to-top characterization parameter	0.1	°C/W
Ψ_{JB}	Junction-to-board characterization parameter	5.4	°C/W
$R_{\theta JC(bot)}$	Junction-to-case (bottom) thermal resistance	1.1	°C/W

(1) For more information about traditional and new thermal metrics, see the [Semiconductor and IC Package Thermal Metrics application report](#).

6.5 Electrical Characteristics

VINDCDC1 = VINDCDC2 = VINDCDC3 = VCC = VINLDO = 3.6 V, VBACKUP = 3 V, $T_A = -40^\circ\text{C}$ to 85°C (unless otherwise noted)

PARAMETER	TEST CONDITIONS	MIN	TYP ⁽¹⁾	MAX	UNIT	
CONTROL SIGNALS: SCLK, SDAT (INPUT) FOR TPS65023						
V_{IH}	High level input voltage (except the SDAT pin)	Resistor pullup at SCLK = 4.7 kΩ, pulled to VRTC	1.3	V_{CC}	V	
V_{IH}	High level input voltage for the SDAT pin	Resistor pullup at SDAT = 4.7 kΩ, pulled to VRTC	1.45	V_{CC}	V	
V_{IL}	Low level input voltage	Resistor pullup at SCLK and SDAT = 4.7 kΩ, pulled to VRTC	0	0.4	V	
I_H	Input bias current		0.01	0.1	μA	
CONTROL SIGNALS: SCLK, SDAT (INPUT) FOR TPS65023B						
V_{IH}	High level input voltage for the SCLK pin	Rpullup at SCLK = 4.7 kΩ, pulled to VRTC; For $V_{CC} = 2.5\text{ V to }5.25\text{ V}$	1.4	V_{CC}	V	
V_{IH}	High level input voltage for the SDAT pin	Rpullup at SDAT = 4.7 kΩ, pulled to VRTC; For $V_{CC} = 2.5\text{ V to }5.25\text{ V}$	1.69	V_{CC}	V	
V_{IH}	High level input voltage for the SDAT pin	Rpullup at SDAT = 4.7 kΩ, pulled to VRTC; For $V_{CC} = 2.5\text{ V to }4.5\text{ V}$	1.55	V_{CC}	V	
V_{IL}	Low level input voltage	Rpullup at SCLK and SDAT = 4.7 kΩ, pulled to VRTC	0	0.35	V	
I_H	Input bias current		0.01	0.1	μA	
CONTROL SIGNALS: HOT_RESET, DCDC1_EN, DCDC2_EN, DCDC3_EN, LDO_EN, DEFLDO1, DEFLDO2						
V_{IH}	High-level input voltage		1.3	V_{CC}	V	
V_{IL}	Low-level input voltage		0	0.4	V	
I_{IB}	Input bias current		0.01	0.1	μA	
$t_{degitch}$	Degitch time at HOT_RESET		25	30	35	ms

(1) Typical values are at $T_A = 25^\circ\text{C}$, unless otherwise noted.

Electrical Characteristics (continued)

VINDCDC1 = VINDCDC2 = VINDCDC3 = VCC = VINLDO = 3.6 V, VBACKUP = 3 V, T_A = –40°C to 85°C (unless otherwise noted)

PARAMETER		TEST CONDITIONS	MIN	TYP ⁽¹⁾	MAX	UNIT
CONTROL SIGNALS: LOWBAT, PWRFAIL, RESPWRON, INT, SDAT (OUTPUT)						
V _{OH}	High-level output voltage				6	V
V _{OL}	Low-level output voltage	I _{IL} = 5 mA	0		0.3	V
	Duration of low pulse at $\overline{\text{RESPWRON}}$	External capacitor 1 nF		100		ms
ICONST	Internal charge / discharge current on pin TRESPWRON	Used for generating $\overline{\text{RESPWRON}}$ delay	1.7	2	2.3	μA
TRESPWRON_LOWTH	Internal lower comparator threshold on pin TRESPWRON	Used for generating $\overline{\text{RESPWRON}}$ delay	0.225	0.25	0.275	V
TRESPWRON_UPTH	Internal upper comparator threshold on pin TRESPWRON	Used for generating $\overline{\text{RESPWRON}}$ delay	0.97	1	1.103	V
	Resetpwron threshold	VRTC falling	–3%	2.4	3%	V
	Resetpwron threshold	VRTC rising	–3%	2.52	3%	V
I _{LK}	Leakage current	Output inactive high			0.1	μA
VLDO1 AND VLDO2 LOW DROPOUT REGULATORS						
V _I	Input voltage range for LDO1, 2		1.5		6.5	V
V _{O(LD01)}	LDO1 output voltage range		1		3.15	V
V _{O(LD02)}	LDO2 output voltage range		1		3.3	V
I _O	Maximum output current for LDO1, LDO2	V _I = 1.8 V, V _O = 1.3 V V _I = 1.5 V, V _O = 1.3 V	200			mA
I _(SC)	LDO1 and LDO2 short-circuit current limit	V _(LD01) = GND, V _(LD02) = GND			400	mA
	Minimum voltage drop at LDO1, LDO2	I _O = 50 mA, VINLDO = 1.8 V			120	mV
		I _O = 50 mA, VINLDO = 1.5 V		65	150	
		I _O = 200 mA, VINLDO = 1.8 V			300	
	Output voltage accuracy for LDO1, LDO2	I _O = 10 mA	–2%		1%	
	Line regulation for LDO1, LDO2	VINLDO1, 2 = VLDO1,2 + 0.5 V (min. 2.5 V) to 6.5 V, I _O = 10 mA	–1%		1%	
	Load regulation for LDO1, LDO2	I _O = 0 mA to 50 mA	–1%		1%	
	Regulation time for LDO1, LDO2	Load change from 10% to 90%		10		μs
ANALOGIC SIGNALS DEFDCDC1, DEFDCDC2, DEFDCDC3						
V _{IH}	High-level input voltage		1.3		VCC	V
V _{IL}	Low-level input voltage		0		0.1	V
	Input bias current			0.001	0.05	μA
THERMAL SHUTDOWN						
T _(SD)	Thermal shutdown	Increasing junction temperature		160		°C
	Thermal shutdown hysteresis	Decreasing junction temperature		20		°C
INTERNAL UNDERVOLTAGE LOCK OUT						
UVLO	Internal UVLO	VCC falling	–2%	2.35	2%	V
V _(UVLO_HYST)	Internal UVLO comparator hysteresis			120		mV
VOLTAGE DETECTOR COMPARATORS						
	Comparator threshold (PWRFAIL_SNS, LOWBAT_SNS)	Falling threshold	–1%	1	1%	V
	Hysteresis		40	50	60	mV
	Propagation delay	25-mV overdrive			10	μs
POWER-GOOD						
V _(PGOODF)		VDCDC1, VDCDC2, VDCDC3, VLDO1, VLDO2, decreasing	–12%	–10%	–8%	
V _(PGOODR)		VDCDC1, VDCDC2, VDCDC3, VLDO1, VLDO2, increasing	–7%	–5%	–3%	

6.6 Electrical Characteristics: Supply Pins VCC, VINDCDC1, VINDCDC2, VINDCDC3

VINDCDC1 = VINDCDC2 = VINDCDC3 = VCC = VINLDO = 3.6 V, VBACKUP = 3 V, T_A = –40°C to 85°C (unless otherwise noted)

PARAMETER	TEST CONDITIONS	MIN	TYP ⁽¹⁾	MAX	UNIT
I _(q) Operating quiescent current, PFM	All 3 DCDC converters enabled, zero load, and no switching, LDOs enabled		85	100	μA
	All 3 DCDC converters enabled, zero load, and no switching, LDOs off		78	90	
	DCDC1 and DCDC2 converters enabled, zero load, and no switching, LDOs off		57	70	
	DCDC1 converter enabled, zero load, and no switching, LDOs off		43	55	
I _i Current into VCC; PWM	All 3 DCDC converters enabled and running in PWM, LDOs off		2	3	mA
	DCDC1 and DCDC2 converters enabled and running in PWM, LDOs off		1.5	2.5	
	DCDC1 converter enabled and running in PWM, LDOs off		0.85	2	
I _(q) Quiescent current	All converters disabled, LDOs off	VCC = 3.6 V, VBACKUP = 3 V; V _(V_{VSYSIN}) = 0 V	23	33	μA
		VCC = 2.6 V, VBACKUP = 3 V; V _(V_{VSYSIN}) = 0 V	3.5	5	μA
		VCC = 3.6 V, VBACKUP = 0 V; V _(V_{VSYSIN}) = 0 V		43	μA

(1) Typical values are at T_A = 25°C, unless otherwise noted.

6.7 Electrical Characteristics: Supply Pins VBACKUP, VSYSIN, VRTC, VINLDO

VINDCDC1 = VINDCDC2 = VINDCDC3 = VCC = VINLDO = 3.6 V, VBACKUP = 3 V, T_A = –40°C to 85°C (unless otherwise noted)

PARAMETER	TEST CONDITIONS	MIN	TYP ⁽¹⁾	MAX	UNIT
VBACKUP, VSYSIN, VRTC					
I _(q) Operating quiescent current	VBACKUP = 3 V, VSYSIN = 0 V; VCC = 2.6 V, current into VBACKUP		20	33	μA
I _(SD) Operating quiescent current	VBACKUP < V _{-VBACKUP} , current into VBACKUP		2	3	μA
VRTC LDO output voltage	VSYSIN = VBACKUP = 0 V, I _O = 0 mA		3		V
I _O Output current for VRTC	VSYSIN < 2.57 V and VBACKUP < 2.57 V			30	mA
VRTC short-circuit current limit	VRTC = GND; VSYSIN = VBACKUP = 0 V			100	mA
Maximum output current at VRTC for RESPWRON = 1	VRTC > 2.6 V, V _{CC} = 3 V; VSYSIN = VBACKUP = 0 V		30		mA
V _O Output voltage accuracy for VRTC	VSYSIN = VBACKUP = 0 V; I _O = 0 mA	–1%		1%	
Line regulation for VRTC	VCC = VRTC + 0.5 V to 6.5 V, I _O = 5 mA	–1%		1%	
Load regulation VRTC	I _O = 1 mA to 30 mA; VSYSIN = VBACKUP = 0 V	–3%		1%	
Regulation time for VRTC	Load change from 10% to 90%		10		μs
I _{lkg} Input leakage current at VSYSIN	VSYSIN < V _{-VSYSIN}			2	μA
r _{DS(on)} of VSYSIN switch				12.5	Ω
r _{DS(on)} of VBACKUP switch				12.5	Ω
Input voltage range at VBACKUP ⁽²⁾		2.73		3.75	V
Input voltage range at VSYSIN ⁽²⁾		2.73		3.75	V
VSYSIN threshold	VSYSIN falling	–3%	2.55	3%	V

(1) Typical values are at T_A = 25°C, unless otherwise noted.

(2) Based on the requirements for the Intel PXA270 processor.

Electrical Characteristics: Supply Pins VBACKUP, VSYSIN, VRTC, VINLDO (continued)

VINDCDC1 = VINDCDC2 = VINDCDC3 = VCC = VINLDO = 3.6 V, VBACKUP = 3 V, T_A = –40°C to 85°C (unless otherwise noted)

PARAMETER		TEST CONDITIONS	MIN	TYP ⁽¹⁾	MAX	UNIT
	VSYSIN threshold	VSYSIN rising	–3%	2.65	3%	V
	VBACKUP threshold	VBACKUP falling	–3%	2.55	3%	V
	VBACKUP threshold	VBACKUP rising	–3%	2.65	3%	V
VINLDO						
I _(q)	Operating quiescent current	Current per LDO into VINLDO for LDO_CTRL = 0x0		16	30	μA
I _(SD)	Shutdown current	Total current for both LDOs into VINLDO, VLDO = 0 V		0.1	1	μA

6.8 Electrical Characteristics: VDCDC1 Step-Down Converter

VINDCDC1 = VINDCDC2 = VINDCDC3 = VCC = VINLDO = 3.6 V, VBACKUP = 3 V, T_A = –40°C to 85°C (unless otherwise noted)

PARAMETER		TEST CONDITIONS	MIN	TYP ⁽¹⁾	MAX	UNIT
V _I	Input voltage range, VINDCDC1		2.5		6	V
I _O	Maximum output current		1700			mA
I _(SD)	Shutdown supply current in VINDCDC1	DCDC1_EN = GND		0.1	1	μA
r _{DS(on)}	P-channel MOSFET on-resistance	VINDCDC1 = V _(GS) = 3.6 V		125	261	mΩ
I _{lkg}	P-channel leakage current	VINDCDC1 = 6 V			2	μA
r _{DS(on)}	N-channel MOSFET on-resistance	VINDCDC1 = V _(GS) = 3.6 V		130	260	mΩ
I _{lkg}	N-channel leakage current	V _(DS) = 6 V		7	10	μA
	Forward current limit (P-channel and N-channel)	2.5 V < V _{I(MAIN)} < 6 V	1.94	2.19	2.44	A
f _S	Oscillator frequency		1.95	2.25	2.55	MHz
	Fixed output voltage FPWMDCDC1 = 0	All VDCDC1 VINDCDC1 = 2.5 V to 6 V; 0 mA ≤ I _O ≤ 1.7 A	–2%		2%	
	Fixed output voltage FPWMDCDC1 = 1		–1%		1%	
	Adjustable output voltage with resistor divider at DEFDCDC1; FPWMDCDC1 = 0	VINDCDC1 = VDCDC1 + 0.5 V (min 2.5 V) to 6 V; 0 mA ≤ I _O ≤ 1.7 A	–2%		2%	
	Adjustable output voltage with resistor divider at DEFDCDC1; FPWMDCDC1 = 1	VINDCDC1 = VDCDC1 + 0.5 V (min 2.5 V) to 6 V; 0 mA ≤ I _O ≤ 1.7 A	–1%		1%	
	Line Regulation	VINDCDC1 = VDCDC1 + 0.3 V (min. 2.5 V) to 6 V; I _O = 10 mA		0%		V
	Load Regulation	I _O = 10 mA to 1700 mA		0.25%		A
t _{Start}	Start-up time	Time from active EN to start switching	145	175	200	μs
t _{Ramp}	V _{OUT} ramp-up time	Time to ramp from 5% to 95% of V _{OUT}	400	750	1000	μs
	Internal resistance from L1 to GND			1		MΩ
	VDCDC1 discharge resistance	DCDC1 discharge = 1		300		Ω

(1) Typical values are at T_A = 25°C, unless otherwise noted.

6.9 Electrical Characteristics: VDCDC2 Step-Down Converter

VINDCDC1 = VINDCDC2 = VINDCDC3 = VCC = VINLDO = 3.6 V, VBACKUP = 3 V, T_A = -40°C to 85°C (unless otherwise noted)

PARAMETER		TEST CONDITIONS	MIN	TYP ⁽¹⁾	MAX	UNIT
V _I	Input voltage range, VINDCDC2		2.5		6	V
I _O	Maximum output current	DEFDCDC2 = GND	1200			mA
		VINDCDC2 = 3.6 V; 3.3 V - 1% ≤ VDCDC2 ≤ 3.3V + 1%	1000			
I _(SD)	Shutdown supply current in VINDCDC2	DCDC2_EN = GND		0.1	1	μA
r _{DS(on)}	P-channel MOSFET on-resistance	VINDCDC2 = V _(GS) = 3.6 V		140	300	mΩ
I _{lkg}	P-channel leakage current	VINDCDC2 = 6 V			2	μA
r _{DS(on)}	N-channel MOSFET on-resistance	VINDCDC2 = V _(GS) = 3.6 V		150	297	mΩ
I _{lkg}	N-channel leakage current	V _(DS) = 6 V		7	10	μA
I _{LIMF}	Forward current limit (P-channel and N-channel)	2.5 V < VINDCDC2 < 6 V	1.74	1.94	2.12	A
f _S	Oscillator frequency		1.95	2.25	2.55	MHz
Fixed output voltage FPWMDCDC2=0	VDCDC2 = 1.8 V	VINDCDC2 = 2.5 V to 6 V; 0 mA ≤ I _O ≤ 1.2 A	-2%		2%	
	VDCDC2 = 3.3 V	VINDCDC2 = 3.7 V to 6 V; 0 mA ≤ I _O ≤ 1.2 A	-1%		1%	
Fixed output voltage FPWMDCDC2=1	VDCDC2 = 1.8 V	VINDCDC2 = 2.5 V to 6 V; 0 mA ≤ I _O ≤ 1.2 A	-2%		2%	
	VDCDC2 = 3.3 V	VINDCDC2 = 3.7 V to 6 V; 0 mA ≤ I _O ≤ 1.2 A	-1%		1%	
Adjustable output voltage with resistor divider at DEFDCDC2 FPWMDCDC2=0		VINDCDC2 = VDCDC2 + 0.3 V (min 2.5 V) to 6 V; 0 mA ≤ I _O ≤ 1 A	-2%		2%	
Adjustable output voltage with resistor divider at DEFDCDC2; FPWMDCDC2=1		VINDCDC2 = VDCDC2 + 0.3 V (min 2.5 V) to 6 V; 0 mA ≤ I _O ≤ 1 A	-1%		1%	
Line Regulation		VINDCDC2 = VDCDC2 + 0.3 V (min. 2.5 V) to 6 V; I _O = 10 mA		0%		V
Load Regulation		I _O = 10 mA to 1000 mA		0.25%		A
t _{Start}	Start-up time	Time from active EN to start switching	145	175	200	μs
t _{Ramp}	V _{OUT} ramp-up time	Time to ramp from 5% to 95% of V _{OUT}	400	750	1000	μs
Internal resistance from L2 to GND				1		MΩ
VDCDC2 discharge resistance		DCDC2 discharge =1		300		Ω

(1) Typical values are at T_A = 25°C, unless otherwise noted.

6.10 Electrical Characteristics: VDCDC3 Step-Down Converter

VINDCDC1 = VINDCDC2 = VINDCDC3 = VCC = VINLDO = 3.6 V, VBACKUP = 3 V, T_A = -40°C to 85°C (unless otherwise noted)

PARAMETER		TEST CONDITIONS	MIN	TYP ⁽¹⁾	MAX	UNIT
V _I	Input voltage range, VINDCDC3		2.5		6	V
I _O	Maximum output current	DEFDCDC3 = GND	1000			mA
		VINDCDC3 = 3.6 V; 3.3V - 1% ≤ VDCDC3 ≤ 3.3V + 1%	525			
I _(SD)	Shutdown supply current in VINDCDC3	DCDC3_EN = GND		0.1	1	μA
r _{DS(on)}	P-channel MOSFET on-resistance	VINDCDC3 = V _(GS) = 3.6 V		310	698	mΩ
I _{lkg}	P-channel leakage current	VINDCDC3 = 6 V		0.1	2	μA
r _{DS(on)}	N-channel MOSFET on-resistance	VINDCDC3 = V _(GS) = 3.6 V		220	503	mΩ
I _{lkg}	N-channel leakage current	V _(DS) = 6 V		7	10	μA
Forward current limit (P-channel and N-channel)		2.5 V < VINDCDC3 < 6 V	1.28	1.49	1.69	A

(1) Typical values are at T_A = 25°C, unless otherwise noted.

Electrical Characteristics: VDCDC3 Step-Down Converter (continued)

VINDCDC1 = VINDCDC2 = VINDCDC3 = VCC = VINLDO = 3.6 V, VBACKUP = 3 V, T_A = –40°C to 85°C (unless otherwise noted)

PARAMETER		TEST CONDITIONS	MIN	TYP ⁽¹⁾	MAX	UNIT
f _S	Oscillator frequency		1.95	2.25	2.55	MHz
Fixed output voltage FPWMDCDC3=0	VDCDC3 = 1.8 V	VINDCDC3 = 2.5 V to 6 V; 0 mA ≤ I _O ≤ 1 A	–2%		2%	
	VDCDC3 = 3.3 V	VINDCDC3 = 3.6 V to 6 V; 0 mA ≤ I _O ≤ 1 A	–1%		1%	
Fixed output voltage FPWMDCDC3=1	VDCDC3 = 1.8 V	VINDCDC3 = 2.5 V to 6 V; 0 mA ≤ I _O ≤ 1 A	–2%		2%	
	VDCDC3 = 3.3 V	VINDCDC3 = 3.6 V to 6 V; 0 mA ≤ I _O ≤ 1 A	–1%		1%	
Adjustable output voltage with resistor divider at DEFDCDC3 FPWMDCDC3=0		VINDCDC3 = VDCDC3 + 0.5 V (min 2.5 V) to 6 V; 0 mA ≤ I _O ≤ 800 mA	–2%		2%	
Adjustable output voltage with resistor divider at DEFDCDC3; FPWMDCDC3=1		VINDCDC3 = VDCDC3 + 0.5 V (min 2.5 V) to 6 V; 0 mA ≤ I _O ≤ 800 mA	–1%		1%	
Line Regulation		VINDCDC3 = VDCDC3 + 0.3 V (min. 2.5 V) to 6 V; I _O = 10 mA		0%		V
Load Regulation		I _O = 10 mA to 1000 mA		0.25%		A
t _{Start}	Start-up time	Time from active EN to start switching	145	175	200	μs
t _{Ramp}	V _{OUT} ramp-up time	Time to ramp from 5% to 95% of V _{OUT}	400	750	1000	μs
	Internal resistance from L3 to GND			1		MΩ
VDCDC3 discharge resistance		DCDC3 discharge =1		300		Ω

6.11 I²C Timing Requirements for TPS65023B

VINDCDC1 = VINDCDC2 = VINDCDC3 = VCC = VINLDO = 2.5 V to 5.5 V, VBACKUP = 3.0 V, T_A = –40 °C to 85 °C

		MIN	MAX	UNIT
f _{MAX}	Clock frequency		400	kHz
t _{wH(HIGH)}	Clock high time	600		ns
t _{wL(LOW)}	Clock low time	1300		ns
t _R	DATA and CLK rise time		300	ns
t _F	DATA and CLK fall time		300	ns
t _{h(STA)}	Hold time (repeated) START condition (after this period the first clock pulse is generated)	600		ns
t _{su(DATA)}	Setup time for repeated START condition	600		ns
t _{h(DATA)}	Data input hold time	100		ns
t _{su(DATA)}	Data input setup time	100		ns
t _{su(STO)}	STOP condition setup time	600		ns
t _(BUF)	Bus free time	1300		ns

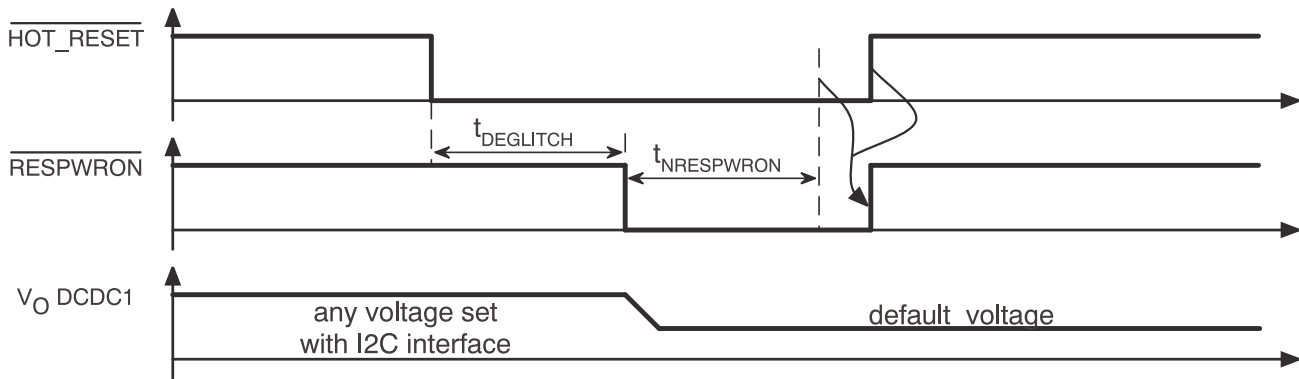

Figure 1. HOT_RESET Timing

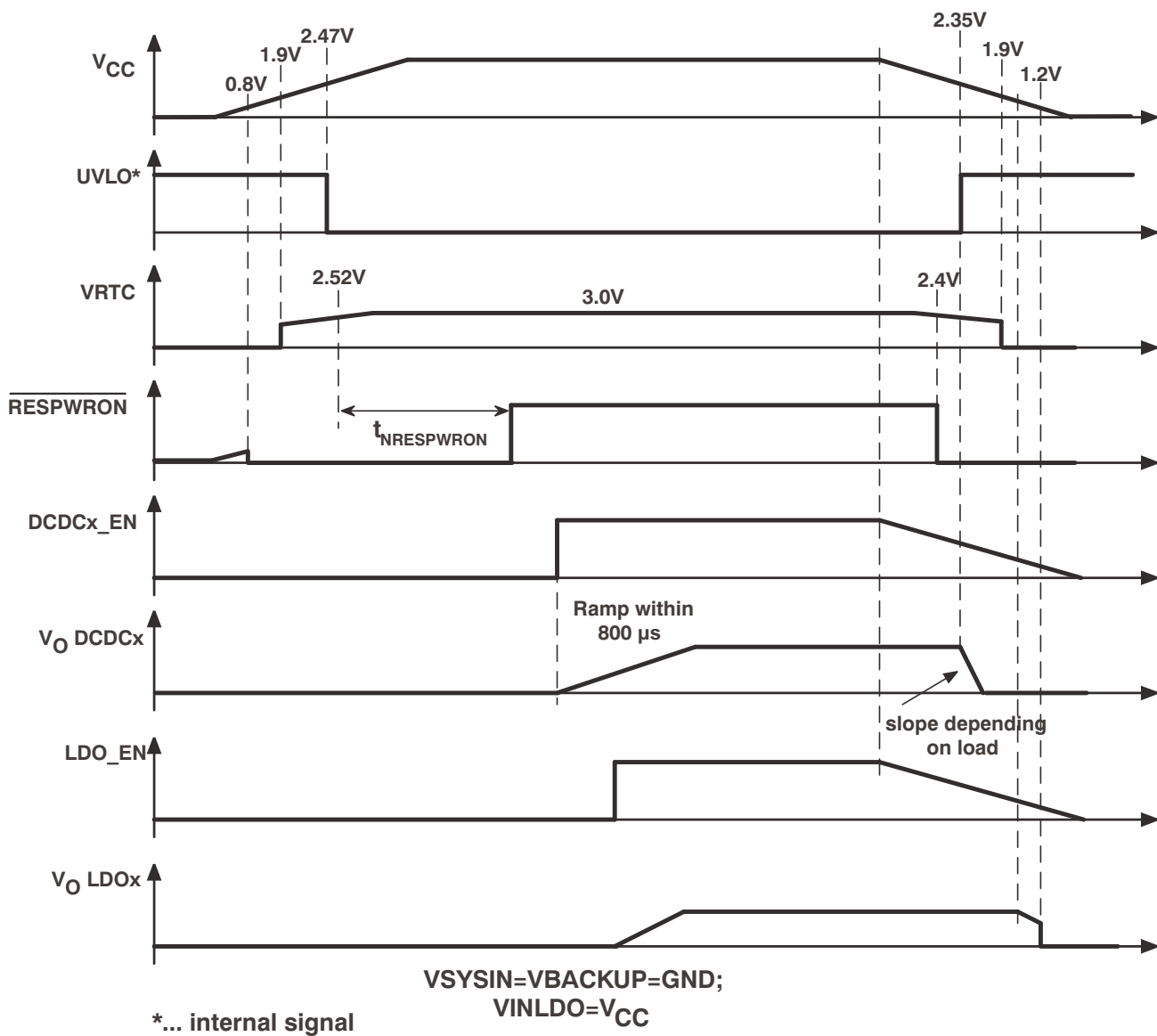

Figure 2. Power-Up and Power-Down Timing

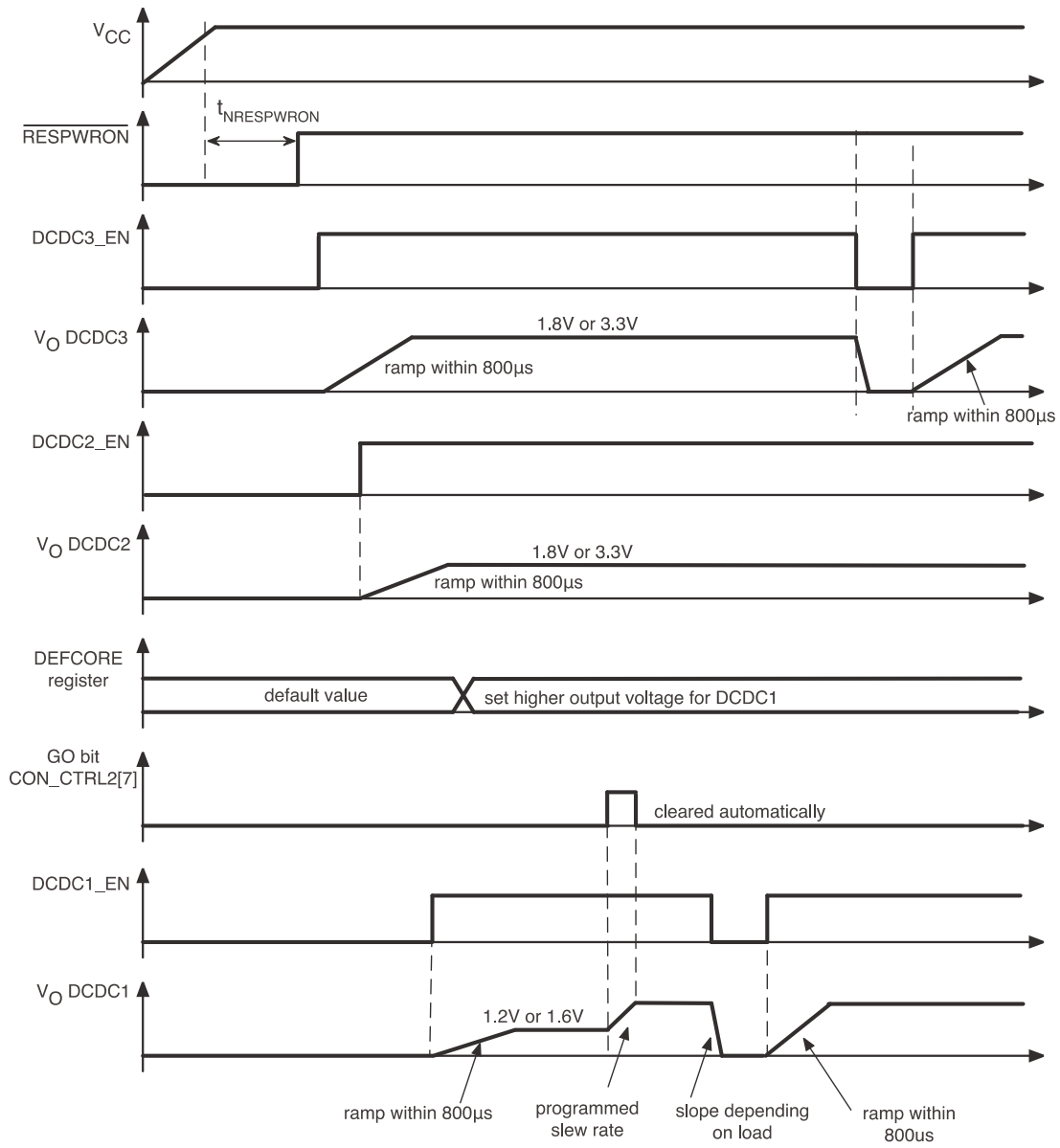

Figure 3. DVS Timing

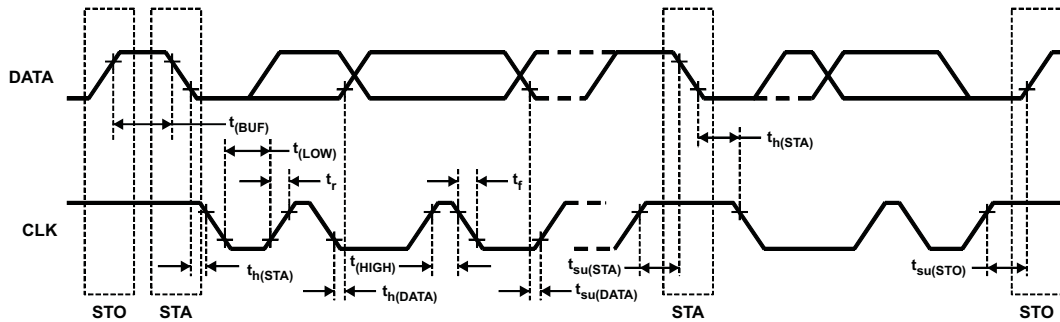

Figure 4. Serial I/F Timing Diagram

6.12 Typical Characteristics

Table 1. Table of Graphs

			FIGURE
η	Efficiency	vs Output current	Figure 5, Figure 6, Figure 7, Figure 8, Figure 9, Figure 10
	Output voltage	vs Output current at 85°C	Figure 11, Figure 12
	Line transient response		Figure 13, Figure 14, Figure 15
	Load transient response		Figure 16, Figure 17, Figure 18
	VDCDC2 PFM operation		Figure 19
	VDCDC2 low ripple PFM operation		Figure 20
	VDCDC2 PWM operation		Figure 21
	Startup VDCDC1, VDCDC2 and VDCDC3		Figure 22
	Startup LDO1 and LDO2		Figure 23
	Line transient response		Figure 24, Figure 25, Figure 26
	Load transient response		Figure 27, Figure 28, Figure 29

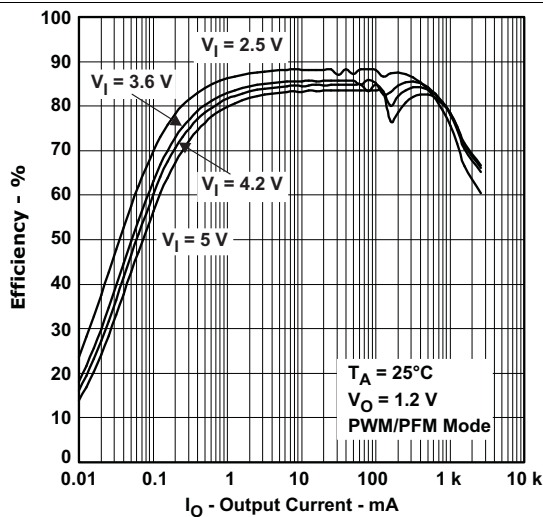

Figure 5. DCDC1: Efficiency vs Output Current

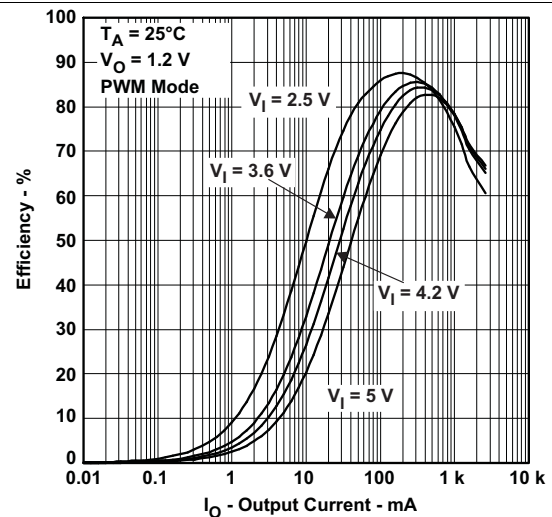

Figure 6. DCDC1: Efficiency vs Output Current

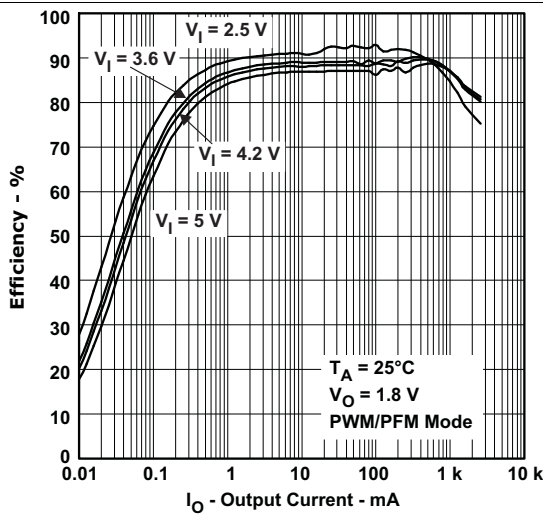

Figure 7. DCDC2: Efficiency vs Output Current

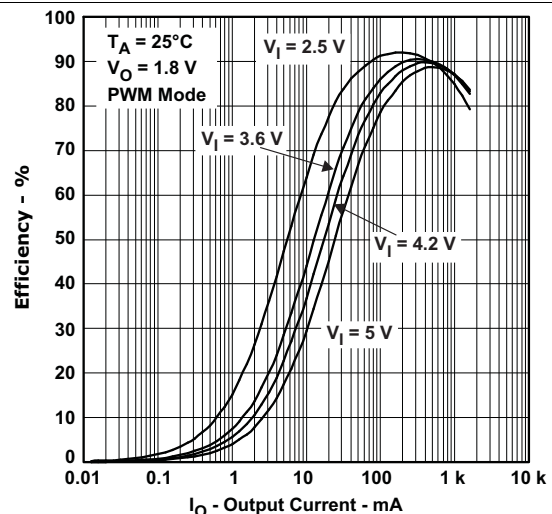

Figure 8. DCDC2: Efficiency vs Output Current

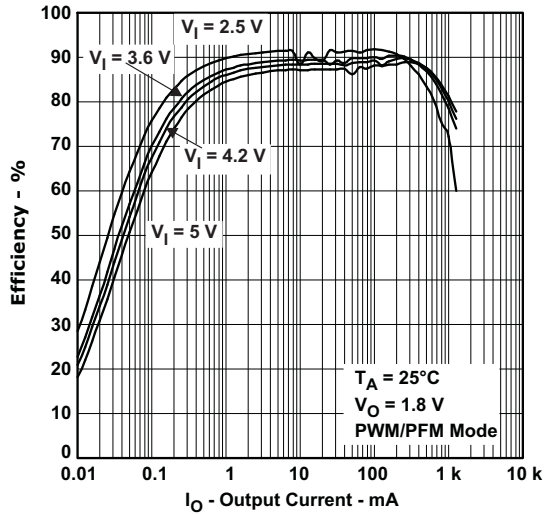

Figure 9. DCDC3: Efficiency vs Output Current

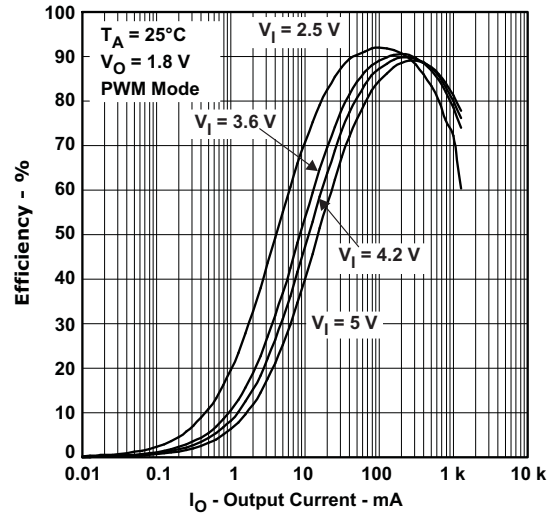

Figure 10. DCDC3: Efficiency vs Output Current

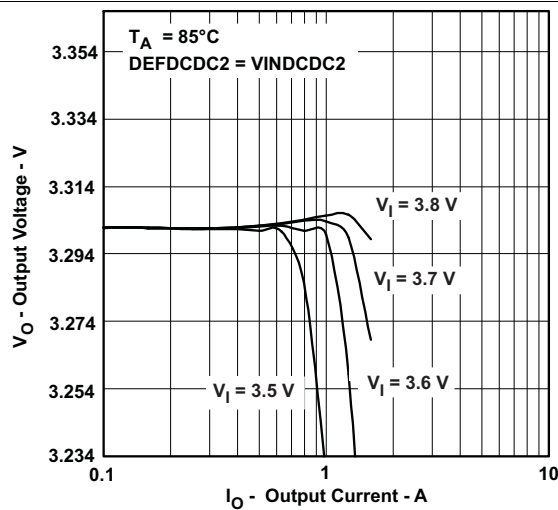

Figure 11. DCDC2: Output Voltage vs Output Current at 85°C

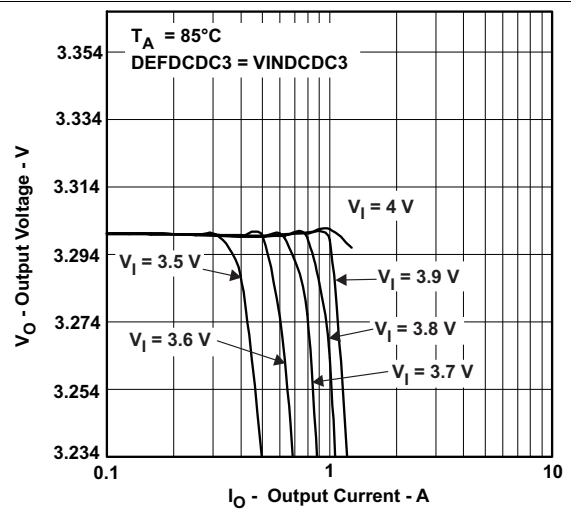

Figure 12. DCDC3: Output Voltage vs Output Current at 85°C

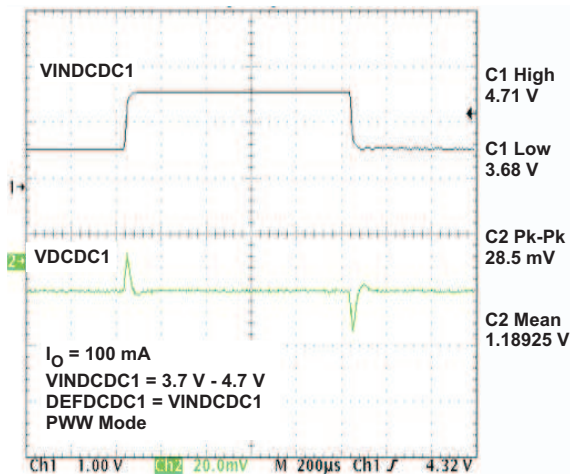

Figure 13. VDCDC1 Line Transient Response

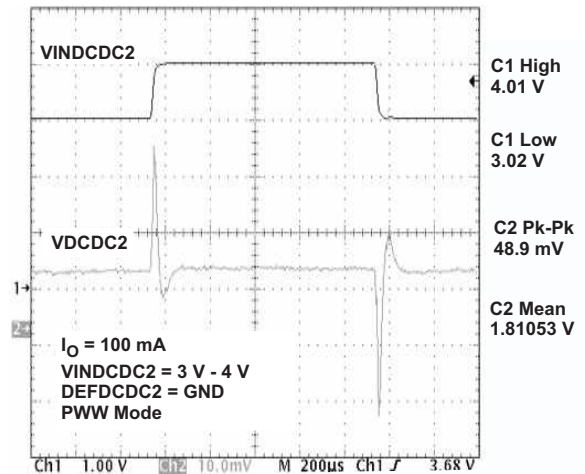
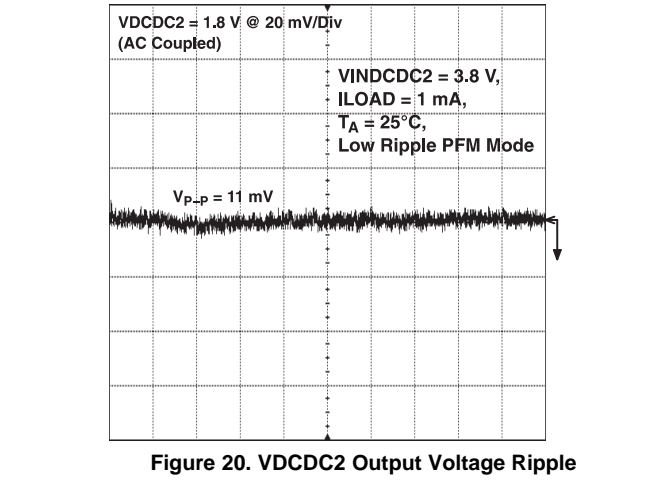
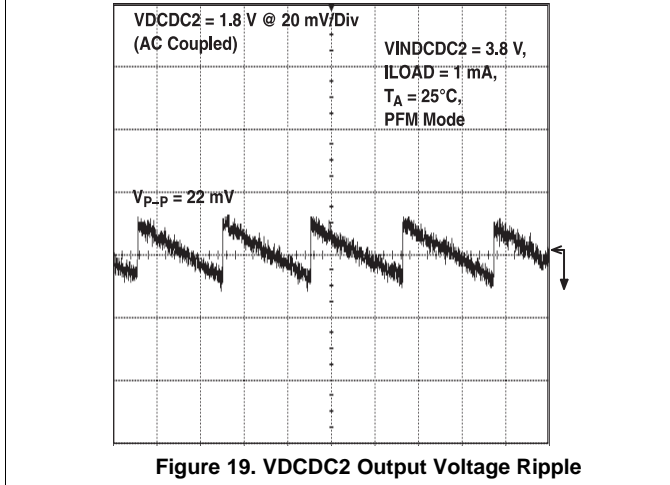
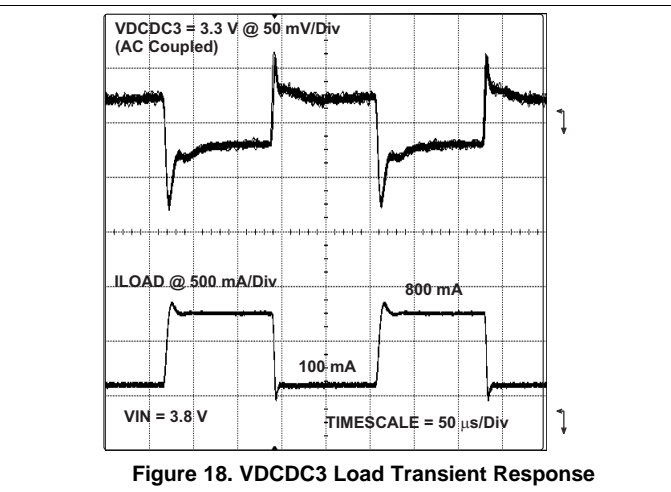
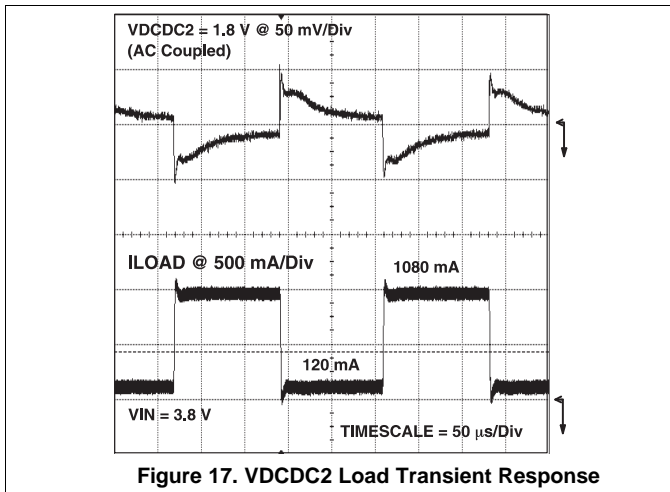
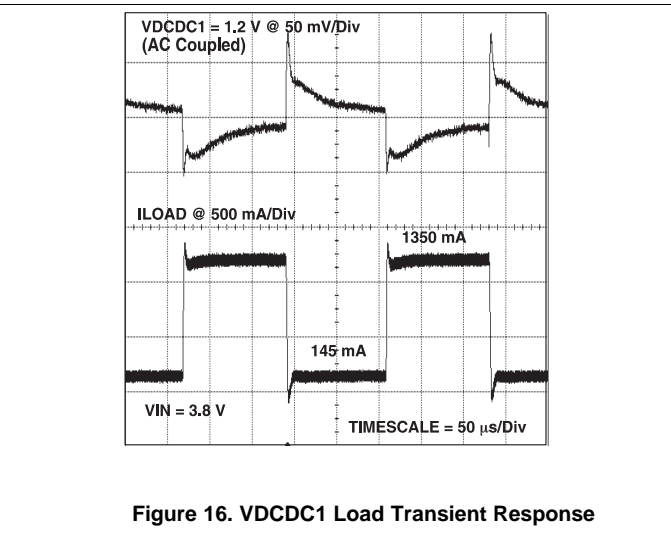
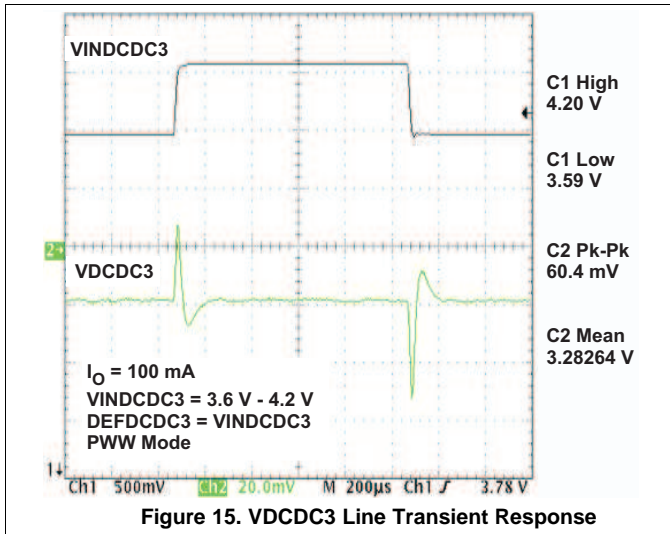

Figure 14. VDCDC2 Line Transient Response



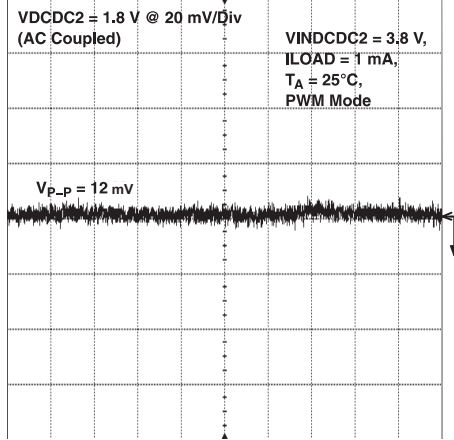

Figure 21. VDCDC2 Output Voltage Ripple

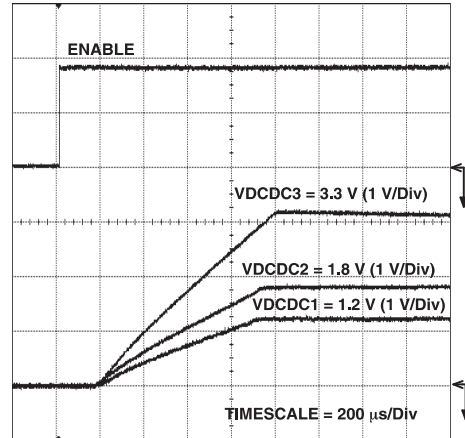

Figure 22. Start-Up VDCDC1, VDCDC2, and VDCDC3

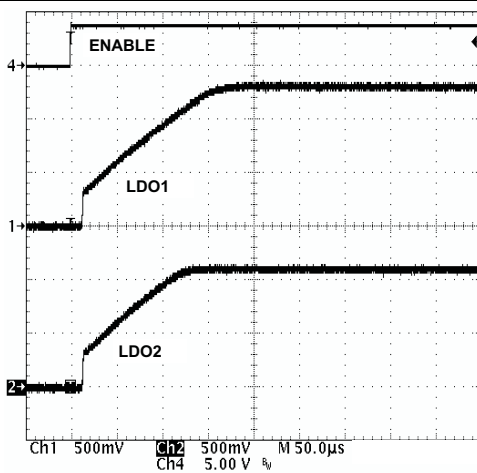

Figure 23. Start-Up LDO1 and LDO2

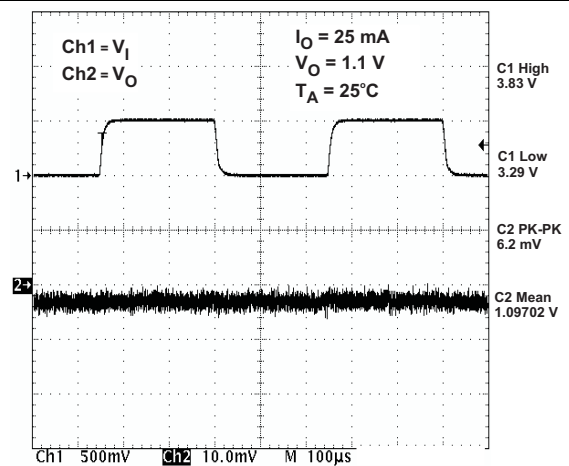

Figure 24. LDO1 Line Transient Response

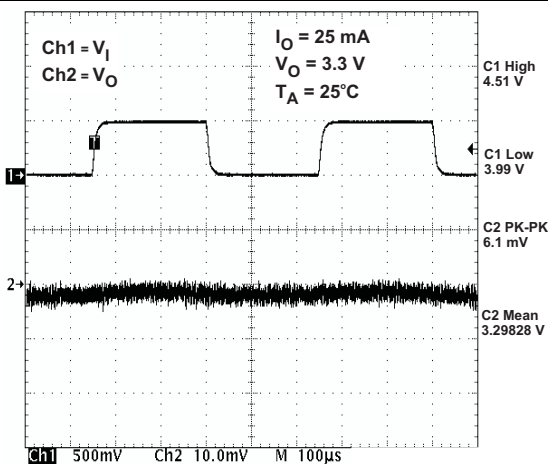

Figure 25. LDO2 Line Transient Response

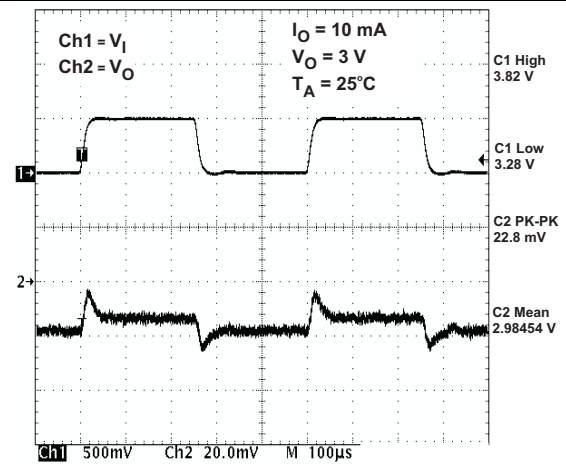
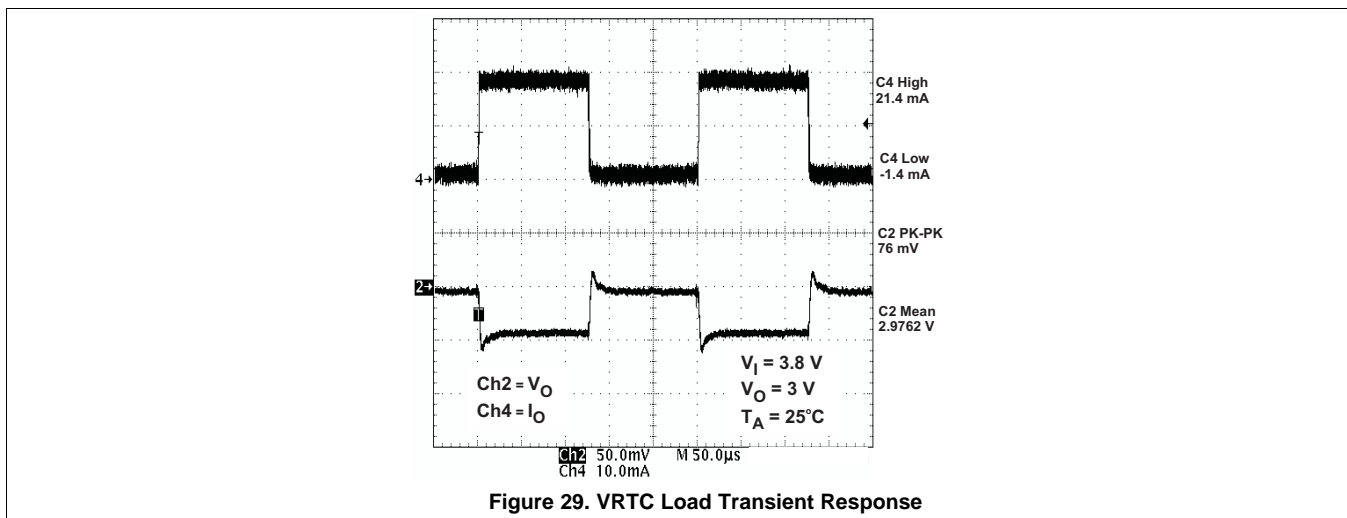
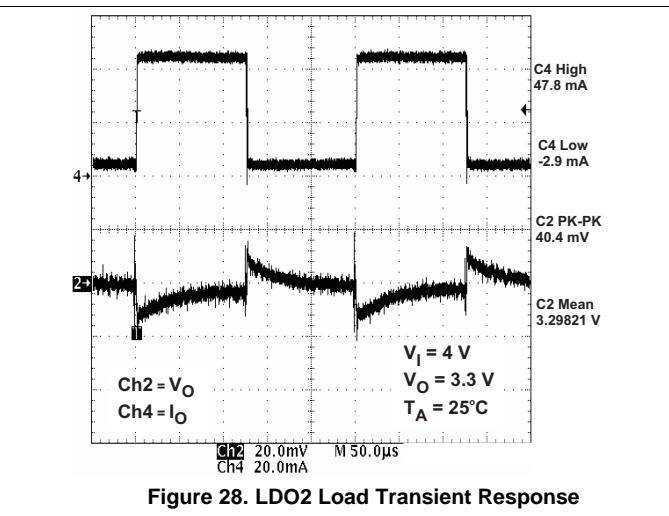
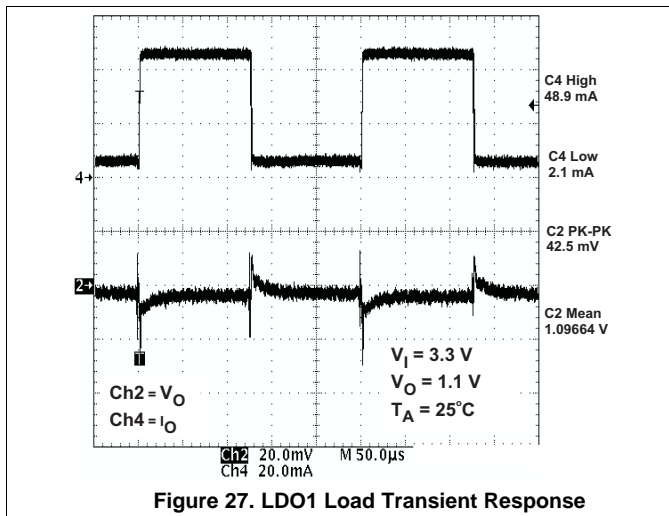

Figure 26. VRTC Line Transient Response



7 Detailed Description

7.1 Overview

TPS65023x has 5 regulator channels, 3 DCDCs and 2 LDOs. DCDC3 has dynamic voltage scaling feature (DVS) that allows for power reduction to CORE supplies during idle operation or overvoltage during heavy-duty operation. With DVS and 2 more DCDCs plus 2 LDOs, the TPS65023x is ideal for CORE, Memory, IO, and peripheral power for the entire system of a wide range of suitable applications.

The device incorporates enables for the DCDCs and LDOs, I²C for device control, push button, and a reset interface that complete the system and allow the TPS65023x to be adapted for different kinds of processors or FPGAs.

For noise-sensitive circuits, the DCDCs can be synchronized out of phase from one another, reducing the peak noise at the switching frequency. Each converter can be forced to operate in PWM mode to ensure constant switching frequency across the entire load range. However, for low load efficiency performance the DCDCs automatically enter PSM mode which reduces the switching frequency when the load current is low, saving power at idle operation.

7.2 Functional Block Diagram

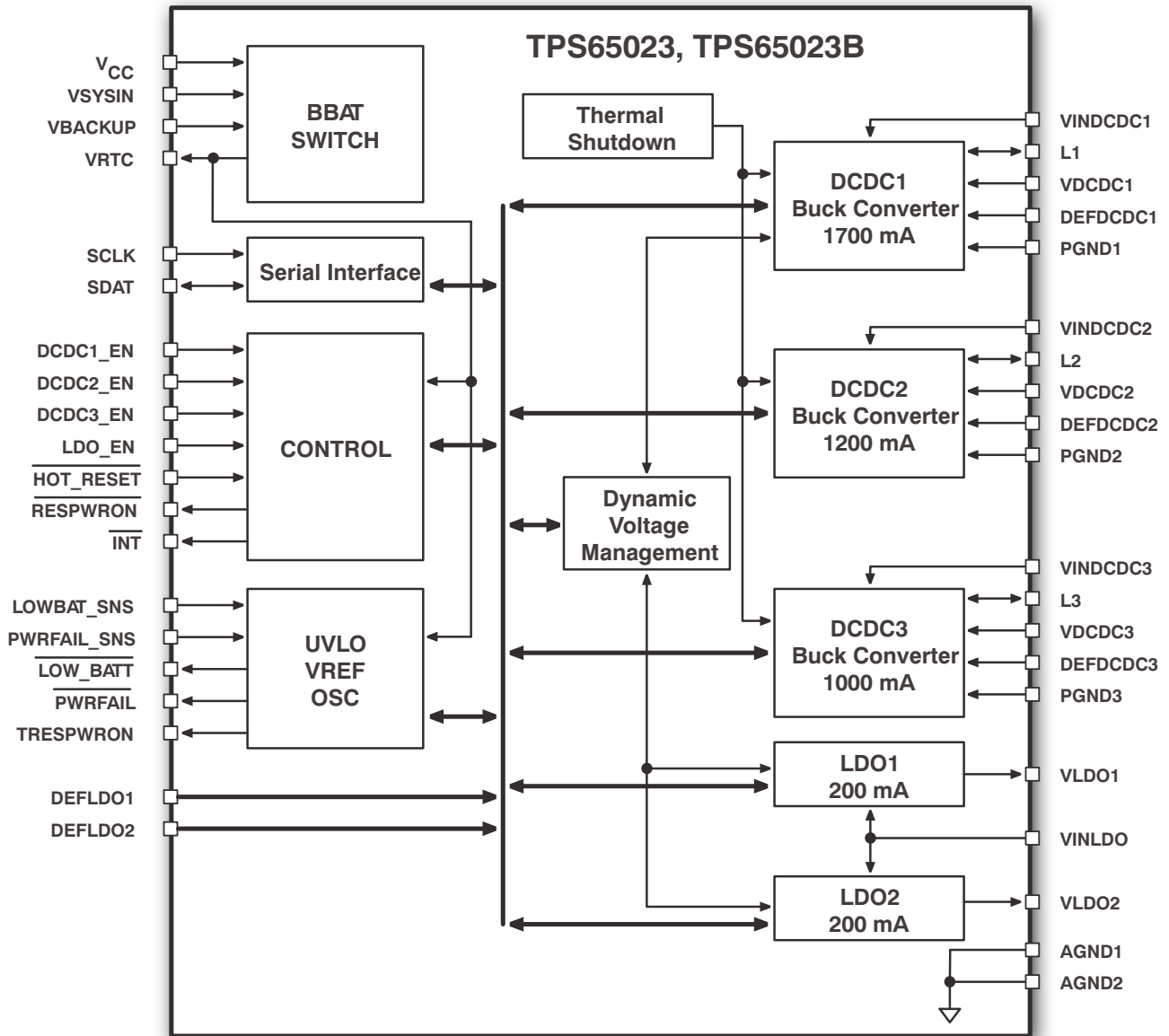

7.3 Feature Description

7.3.1 VRTC Output and Operation With or Without Backup Battery

The VRTC pin is an always-on output, intended to supply up to 30 mA to a permanently required rail (that is, for a real time clock). The TPS65023x asserts the RESPWRON signal if VRTC drops below 2.4 V. VRTC is selected from a priority scheme based on the VSYSIN and VBACKUP inputs.

When the voltage at the VSYSIN pin exceeds 2.65 V, VRTC connects to the VSYSIN input through a PMOS switch and all other paths to VRTC are disabled. The PMOS switch drops a maximum of 375 mV at 30 mA, which must be considered when using VRTC. VSYSIN can be connected to any voltage source with the appropriate input voltage, including VCC or, if set to 3.3-V output, DCDC2 or DCDC3. When VSYSIN falls below 2.65 V or shorts to ground, the PMOS switch connecting VRTC and VSYSIN opens and VRTC then connects to either VBACKUP or the output of a dedicated 3-V or 30-mA LDO.

Feature Description (continued)

NOTE

Texas Instruments recommends connecting VSYSIN to VCC or ground – VCC if a non-replaceable primary cell is connected to VBACKUP and ground if the VRTC output will float.

If the PMOS switch between VSYSIN and VRTC is open and VBACKUP exceeds 2.65 V, VRTC connects to VBACKUP through a PMOS switch. The PMOS switch drops a maximum of 375 mV at 30 mA, which must be considered if using VRTC. A typical application may connect VBACKUP to a primary Li button cell, but any battery that provides a voltage between 2.65 V and 6 V (that is, a single Li-Ion cell or a single boosted NiMH battery) is acceptable, to supply the VRTC output.

NOTE

In systems with no backup battery, the VBACKUP pin must be connected to GND.

If the switches between VRTC and VSYSIN or VBACKUP are open, the dedicated 3-V or 30-mA LDO, driven from VCC, connects to VRTC. This LDO is disabled if the voltage at the VSYSIN input exceeds 2.65 V.

Inside TPS65023x there is a switch (Vmax switch) which selects the higher voltage between V_{CC} and VBACKUP. This is used as the supply voltage for some basic functions. The functions powered from the output of the Vmax switch are:

- $\overline{\text{INT}}$ output
- $\overline{\text{RESPWRON}}$ output
- $\overline{\text{HOT_RESET}}$ input
- $\overline{\text{LOW_BATT}}$ output
- $\overline{\text{PWRFAIL}}$ output
- Enable pins for DC-DC converters, LDO1 and LDO2
- Undervoltage lockout comparator (UVLO)
- Reference system with low frequency timing oscillators
- $\overline{\text{LOW_BATT}}$ and $\overline{\text{PWRFAIL}}$ comparators

The main 2.25-MHz oscillator, and the I²C interface are only powered from V_{CC}.

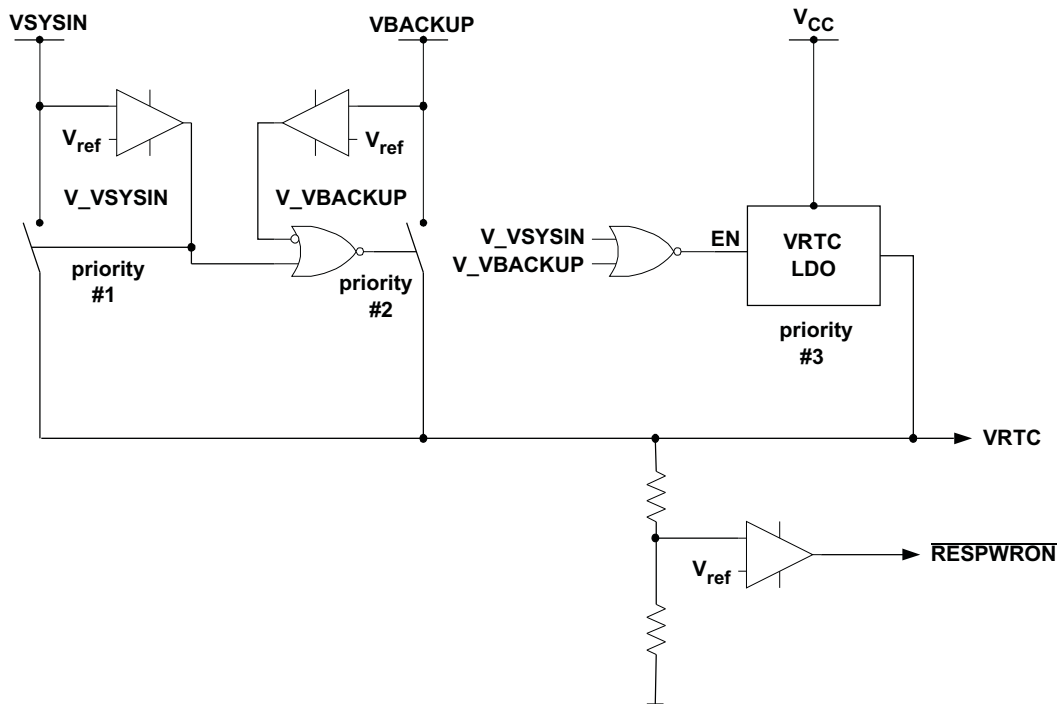
Feature Description (continued)

- A. $V_V\text{SYSIN}$, $V_V\text{BACKUP}$ thresholds: falling = 2.55 V, rising = 2.65 V $\pm 3\%$
 B. RESPWRON thresholds: falling = 2.4 V, rising = 2.52 V $\pm 3\%$

Figure 30. RTC and nRESPWRON
7.3.2 Step-Down Converters, VDCDC1, VDCDC2, and VDCDC3

The TPS65023x incorporates three synchronous step-down converters operating typically at 2.25-MHz, fixed frequency pulse width modulation (PWM) at moderate to heavy-load currents. At light-load currents, the converters automatically enter the power save mode (PSM), and operate with pulse frequency modulation (PFM). The VDCDC1 converter is capable of delivering 1.5-A output current, the VDCDC2 converter is capable of delivering 1.2 A and the VDCDC3 converter is capable of delivering up to 1 A.

The converter output voltages can be programmed through the DEFDCDC1, DEFDCDC2, and DEFDCDC3 pins. The pins can either be connected to GND, VCC, or to a resistor divider between the output voltage and GND. The VDCDC1 converter defaults to 1.2 V or 1.6 V depending on the DEFDCDC1 configuration pin. If DEFDCDC1 is tied to ground, the default is 1.2 V. If it is tied to VCC, the default is 1.6 V. When the DEFDCDC1 pin is connected to a resistor divider, the output voltage can be set in the range of 0.6 V to V_{INDCDC1} V. See [Application Information](#) for more details. The core voltage can be reprogrammed through the serial interface in the range of 0.8 V to 1.6 V with a programmable slew rate. The converter is forced into PWM operation whilst any programmed voltage change is underway, whether the voltage is being increased or decreased. The DEFDCDC1 and DEFDCDC2 registers are used to program the output voltage and slew rate during voltage transitions.

The VDCDC2 converter defaults to 1.8 V or 3.3 V depending on the DEFDCDC2 configuration pin. If DEFDCDC2 is tied to ground, the default is 1.8 V. If it is tied to VCC, the default is 3.3 V. When the DEFDCDC2 pin is connected to a resistor divider, the output voltage can be set in the range of 0.6 V to V_{INDCDC2} V.

The VDCDC3 converter defaults to 1.8 V or 3.3 V depending on the DEFDCDC3 configuration pin. If DEFDCDC3 is tied to ground the default is 1.8 V. If it is tied to VCC, the default is 3.3 V. When the DEFDCDC3 pin is connected to a resistor divider, the output voltage can be set in the range of 0.6 V to V_{INDCDC3} V.

The step-down converter outputs (when enabled) are monitored by power-good (PG) comparators, the outputs of which are available through the serial interface. The outputs of the DC-DC converters can be optionally discharged through on-chip 300- Ω resistors when the DC-DC converters are disabled.

Feature Description (continued)

During PWM operation, the converters use a unique fast response voltage mode controller scheme with input voltage feedforward to achieve good line and load regulation allowing the use of small ceramic input and output capacitors. At the beginning of each clock cycle initiated by the clock signal, the P-channel MOSFET switch is turned on. The inductor current ramps up until the comparator trips and the control logic turns off the switch. The current limit comparator also turns off the switch if the current limit of the P-channel switch is exceeded. After the adaptive dead-time used to prevent shoot through current, the N-channel MOSFET rectifier is turned on, and the inductor current ramps down. The next cycle is initiated by the clock signal, again turning off the N-channel rectifier and turning on the P-channel switch.

The three DC-DC converters operate synchronized to each other with the VDCDC1 converter as the master. A 180° phase shift between the VDCDC1 switch turn on and the VDCDC2 and a further 90° shift to the VDCDC3 switch turn on decreases the input RMS current and smaller input capacitors can be used. This is optimized for a typical application where the VDCDC1 converter regulates a Li-Ion battery voltage of 3.7 V to 1.2 V, the VDCDC2 converter from 3.7 V to 1.8 V, and the VDCDC3 converter from 3.7 V to 3.3 V. The phase of the three converters can be changed using the CON_CTRL register.

7.3.3 Power Save Mode Operation

As the load current decreases, the converters enter the power save mode operation. During PSM, the converters operate in a burst mode (PFM mode) with a frequency between 750 kHz and 2.25 MHz, nominal for one burst cycle. However, the frequency between different burst cycles depends on the actual load current and is typically far less than the switching frequency with a minimum quiescent current to maintain high efficiency.

To optimize the converter efficiency at light load, the average current is monitored and if in PWM mode the inductor current remains below a certain threshold, then PSM is entered. The typical threshold to enter PSM is calculated as shown in [Equation 1](#), [Equation 2](#) and [Equation 3](#).

$$I_{PFMDCDC1 \text{ enter}} = \frac{V_{INDCDC1}}{24 \Omega} \quad (1)$$

$$I_{PFMDCDC2 \text{ enter}} = \frac{V_{INDCDC2}}{26 \Omega} \quad (2)$$

$$I_{PFMDCDC3 \text{ enter}} = \frac{V_{INDCDC3}}{39 \Omega} \quad (3)$$

During the PSM the output voltage is monitored with a comparator, and by maximum skip burst width. As the output voltage falls below the threshold, set to the nominal V_O , the P-channel switch turns on and the converter effectively delivers a constant current defined in [Equation 4](#), [Equation 5](#) and [Equation 6](#).

$$I_{PFMDCDC1 \text{ leave}} = \frac{V_{INDCDC1}}{18 \Omega} \quad (4)$$

$$I_{PFMDCDC2 \text{ leave}} = \frac{V_{INDCDC2}}{20 \Omega} \quad (5)$$

$$I_{PFMDCDC3 \text{ leave}} = \frac{V_{INDCDC3}}{29 \Omega} \quad (6)$$

If the load is below the delivered current then the output voltage rises until the same threshold is crossed in the other direction. All switching activity ceases, reducing the quiescent current to a minimum until the output voltage has again dropped below the threshold. The power save mode is exited, and the converter returns to PWM mode if either of the following conditions are met:

1. the output voltage drops 2% below the nominal V_O due to increasing load current
2. the PFM burst time exceeds $16 \times 1/f_s$ (7.11 μ s typical).

These control methods reduce the quiescent current to typically 14 μ A per converter, and the switching activity to a minimum, thus achieving the highest converter efficiency. Setting the comparator thresholds at the nominal output voltage at light-load current results in a low output voltage ripple. The ripple depends on the comparator delay and the size of the output capacitor. Increasing capacitor values makes the output ripple tend to zero. The PSM is disabled through the I²C interface to force the individual converters to stay in fixed frequency PWM mode.

Feature Description (continued)

7.3.4 Low Ripple Mode

Setting bit 3 in register CON_CTRL to 1 enables the low ripple mode for all of the DC-DC converters if operated in PFM mode. For an output current less than approximately 10 mA, the output voltage ripple in PFM mode is reduced, depending on the actual load current. The lower the actual output current on the converter, the lower the output ripple voltage. For an output current above 10 mA, there is only minor difference in output voltage ripple between PFM mode and low ripple PFM mode. As this feature also increases switching frequency, it is used to keep the switching frequency above the audible range in PFM mode down to a low output current.

7.3.5 Soft-Start

Each of the three converters has an internal soft-start circuit that limits the inrush current during start-up. The soft-start is realized by using a low current to initially charge the internal compensation capacitor. The soft-start time is typically 750 μ s if the output voltage ramps from 5% to 95% of the final target value. If the output is already precharged to some voltage when the converter is enabled, then this time is reduced proportionally. There is a short delay of typically 170 μ s between the converter being enabled and switching activity actually starting. This allows the converter to bias itself properly, to recognize if the output is precharged, and if so to prevent discharging of the output while the internal soft-start ramp catches up with the output voltage.

7.3.6 100% Duty Cycle Low Dropout Operation

The TPS65023x converters offer a low input to output voltage difference while still maintaining operation with the use of the 100% duty cycle mode. In this mode the P-channel switch is constantly turned on. This is particularly useful in battery-powered applications to achieve longest operation time by taking full advantage of the whole battery voltage range. The minimum input voltage required to maintain DC regulation depends on the load current and output voltage. It is calculated in [Equation 7](#).

$$V_{in_{min}} = V_{out_{min}} + I_{out_{max}} \times (r_{DS(on)_{max}} + R_L)$$

where

- $I_{out_{max}}$ = maximum load current (Note: ripple current in the inductor is zero under these conditions)
- $r_{DS(on)_{max}}$ = maximum P-channel switch $r_{DS(on)}$
- R_L = DC resistance of the inductor
- $V_{out_{min}}$ = nominal output voltage minus 2% tolerance limit (7)

7.3.7 Active Discharge When Disabled

When the VDCDC1, VDCDC2, and VDCDC3 converters are disabled, due to an UVLO, DCDC_EN or OVERTEMP condition, it is possible to actively pull down the outputs. This feature is disabled per default and is individually enabled through the CON_CTRL2 register in the serial interface. When this feature is enabled, the VDCDC1, VDCDC2, and VDCDC3 outputs are discharged by a 300- Ω (typical) load which is active as long as the converters are disabled.

7.3.8 Power-Good Monitoring

All three step-down converters and both the LDO1 and LDO2 linear regulators have power-good comparators. Each comparator indicates when the relevant output voltage has dropped 10% below its target value with 5% hysteresis. The outputs of these comparators are available in the PGOODZ register through the serial interface. An interrupt is generated when any voltage rail drops below the 10% threshold. The comparators are disabled when the converters are disabled and the relevant PGOODZ register bits indicate that power is good.

Feature Description (continued)

7.3.9 Low-Dropout Voltage Regulators

The low-dropout voltage regulators are designed to operate well with low-value ceramic input and output capacitors. They operate with input voltages down to 1.5 V. The LDOs offer a maximum dropout voltage of 300 mV at rated output current. Each LDO supports a current limit feature. Both LDOs are enabled by the LDO_EN pin, both LDOs can be disabled or programmed through the serial interface using the REG_CTRL and LDO_CTRL registers. The LDOs also have reverse conduction prevention. This allows the possibility to connect external regulators in parallel in systems with a backup battery. The TPS65023x step-down and LDO voltage regulators automatically power down when the V_{CC} voltage drops below the UVLO threshold or when the junction temperature rises above 160°C.

7.3.10 Undervoltage Lockout

The undervoltage lockout circuit for the five regulators on the TPS65023x prevents the device from malfunctioning at low-input voltages and from excessive discharge of the battery. It disables the converters and LDOs. The UVLO circuit monitors the VCC pin, the threshold is set internally to 2.35 V with 5% (120 mV) hysteresis. When any of the DC-DC converters are running, there is an input current at the VCC pin, which is up to 3 mA when all three converters are running in PWM mode. Consider this current if an external RC filter is used at the VCC pin to remove switching noise from the TPS65023x internal analog circuitry supply.

7.3.11 Power-Up Sequencing

The TPS65023x power-up sequencing is designed to be entirely flexible and customer driven. This is achieved by providing separate enable pins for each switch-mode converter, and a common enable signal for the LDOs. The relevant control pins are described in [Table 2](#).

Table 2. Control Pins and Status Outputs for DC–DC Converters

PIN NAME	I/O	FUNCTION
DEFDCDC3	I	Defines the default voltage of the VDCDC3 switching converter. DEFDCDC3 = 0 defaults VDCDC3 to 1.8 V, DEFDCDC3 = VCC defaults VDCDC3 to 3.3 V.
DEFDCDC2	I	Defines the default voltage of the VDCDC2 switching converter. DEFDCDC2 = 0 defaults VDCDC2 to 1.8 V, DEFDCDC2 = VCC defaults VDCDC2 to 3.3 V.
DEFDCDC1	I	Defines the default voltage of the VDCDC1 switching converter. DEFDCDC1 = 0 defaults VDCDC1 to 1.2 V, DEFDCDC1 = VCC defaults VDCDC1 to 1.6 V.
DCDC3_EN	I	Set DCDC3_EN = 0 to disable and DCDC3_EN = 1 to enable the VDCDC3 converter
DCDC2_EN	I	Set DCDC2_EN = 0 to disable and DCDC2_EN = 1 to enable the VDCDC2 converter
DCDC1_EN	I	Set DCDC1_EN = 0 to disable and DCDC1_EN = 1 to enable the VDCDC1 converter
$\overline{\text{HOT_RESET}}$	I	The $\overline{\text{HOT_RESET}}$ pin generates a reset ($\overline{\text{RESPWRON}}$) for the processor. $\overline{\text{HOT_RESET}}$ does not alter any TPS65023x settings except the output voltage of VDCDC1. Activating $\overline{\text{HOT_RESET}}$ sets the voltage of VDCDC1 to its default value defined with the DEFDCDC1 pin. $\overline{\text{HOT_RESET}}$ is internally de-bounced by the TPS65023x.
RESPWRON	O	$\overline{\text{RESPWRON}}$ is held low when power is initially applied to the TPS65023x. The VRTC voltage is monitored: $\overline{\text{RESPWRON}}$ is low when VRTC < 2.4 V and remains low for a time defined by the external capacitor at the TRESPWRON pin. $\overline{\text{RESPWRON}}$ can also be forced low by activation of the $\overline{\text{HOT_RESET}}$ pin.
TRESPWRON	I	Connect a capacitor here to define the RESET time at the $\overline{\text{RESPWRON}}$ pin (1 nF typically gives 100 ms).

7.4 Device Functional Modes

The TPS6502x devices are either in the ON or the OFF mode. The OFF mode is entered when the voltage on VCC is below the UVLO threshold, 2.35 V (typically). Once the voltage at VCC has increased above UVLO, the device enters ON mode. In the ON mode, the DCDCs and LDOs are available for use.

7.5 Programming

7.5.1 System Reset + Control Signals

The $\overline{\text{RESPWRON}}$ signal can be used as a global reset for the application. It is an open-drain output. The $\overline{\text{RESPWRON}}$ signal is generated according to the power-good comparator of VRTC, and remains low for t_{respwrn} seconds after VRTC has risen above 2.52 V (falling threshold is 2.4 V, 5% hysteresis). t_{respwrn} is set by an external capacitor at the TRESPWRON pin. 1 nF gives typically 100 ms. $\overline{\text{RESPWRON}}$ is also triggered by the $\overline{\text{HOT_RESET}}$ input. This input is internally debounced, with a filter time of typically 30 ms.

The $\overline{\text{PWRFAIL}}$ and $\overline{\text{LOW_BAT}}$ signals are generated by two voltage detectors using the PWRFAIL_SNS and LOWBAT_SNS input signals. Each input signal is compared to a 1-V threshold (falling edge) with 5% (50 mV) hysteresis.

The DCDC1 converter is reset to its default output voltage defined by the DEFDCDC1 input, when $\overline{\text{HOT_RESET}}$ is asserted. Other I²C registers are not affected. Generally, the DCDC1 converter is set to its default voltage with one of these conditions: $\overline{\text{HOT_RESET}}$ active, VRTC lower than its threshold voltage, undervoltage lockout (UVLO) condition, or $\overline{\text{RESPWRON}}$ active.

7.5.1.1 DEFLDO1 and DEFLDO2

These two pins are used to set the default output voltage of the two 200-mA LDOs. The digital value applied to the pins is latched during power up and determines the initial output voltage according to Table 3. The voltage of both LDOs can be changed during operation with the I²C interface as described in the interface description.

Table 3. LDO1 and LDO2 Default Voltage Options

DEFLDO2	DEFLDO1	VLDO1	VLDO2
0	0	1.3 V	3.3 V
0	1	2.8 V	3.3 V
1	0	1.3 V	1.8 V
1	1	1.8 V	3.3 V

7.5.1.2 Interrupt Management and the $\overline{\text{INT}}$ Pin

The $\overline{\text{INT}}$ pin combines the outputs of the PGOOD comparators from each DC–DC converter and the LDOs. The $\overline{\text{INT}}$ pin is used as a POWER_OK pin to indicate when all enabled supplies are in regulation. The $\overline{\text{INT}}$ pin remains active (low state) during power up as long as all enabled power rails are below their regulation limit. Once the last enabled power rail is within regulation, the $\overline{\text{INT}}$ pin transitions to a high state.

During operation, if one of the enabled supplies goes out of regulation, $\overline{\text{INT}}$ transitions to a low state, and the corresponding bit in the PGOODZ register goes high. If the supply goes back to its regulation limits, $\overline{\text{INT}}$ transitions back to a high state.

While $\overline{\text{INT}}$ is in an active-low state, reading the PGOODZ register through the I²C bus forces $\overline{\text{INT}}$ into a high-Z state. Because this pin requires an external pullup resistor, the $\overline{\text{INT}}$ pin transitions to a logic high state even though the supply in question is still out of regulation. The corresponding bit in the PGOODZ register still indicates that the power rail is out of regulation.

Interrupts can be masked using the MASK register; default operation is not to mask any DCDC or LDO interrupts because this provides the POWER_OK function. If none of the DCDC converters or LDos are enabled, $\overline{\text{INT}}$ defaults to a low state independently of the settings of the MASK register.

7.5.2 Serial Interface

The serial interface is compatible with the standard and fast mode I²C specifications, allowing transfers at up to 400 kHz. The interface adds flexibility to the power supply solution, enabling most functions to be programmed to new values depending on the instantaneous application requirements and charger status to be monitored. Register contents remain intact as long as V_{CC} remains above 2 V. The TPS65023x has a 7-bit address: 1001000, other addresses are available upon contact with the factory. Attempting to read data from the register addresses not listed in this section results in FFh being read out.

For normal data transfer, DATA is allowed to change only when CLK is low. Changes when CLK is high are reserved for indicating the start and stop conditions. During data transfer, the data line must remain stable whenever the clock line is high. There is one clock pulse per bit of data. Each data transfer is initiated with a start condition and terminated with a stop condition. When addressed, the TPS65023x device generates an acknowledge bit after the reception of each byte. The master device (microprocessor) must generate an extra clock pulse that is associated with the acknowledge bit. The TPS65023x device must pull down the DATA line during the acknowledge clock pulse so that the DATA line is a stable low during the high period of the acknowledge clock pulse. The DATA line is a stable low during the high period of the acknowledge-related clock pulse. Setup and hold times must be taken into account. During read operations, a master must signal the end of data to the slave by not generating an acknowledge bit on the last byte that was clocked out of the slave. In this case, the slave TPS65023x device must leave the data line high to enable the master to generate the stop condition. See [fC Timing Requirements for TPS65023B](#) for more information.

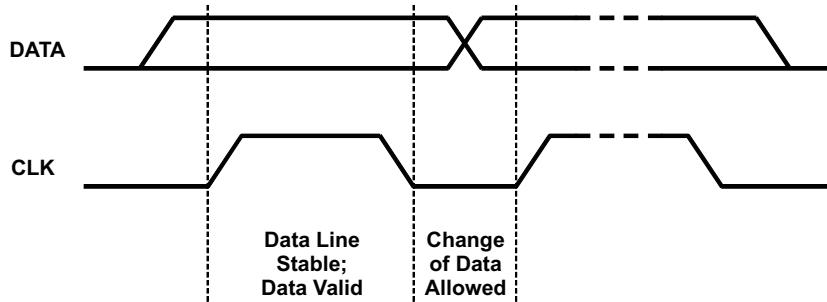

Figure 31. Bit Transfer on the Serial Interface

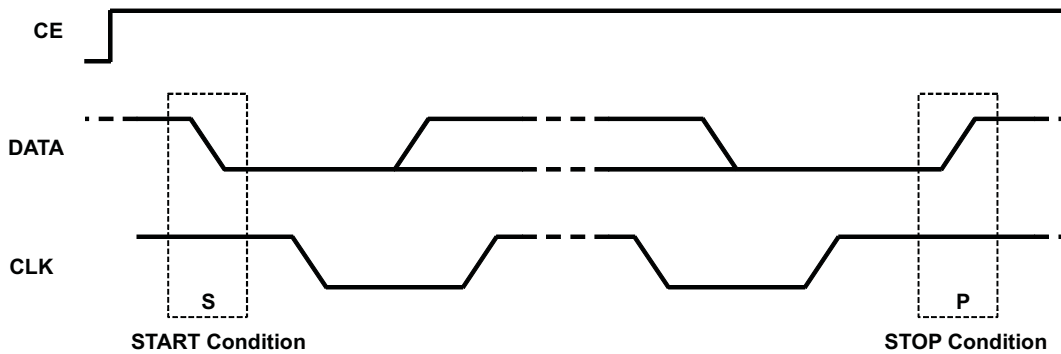
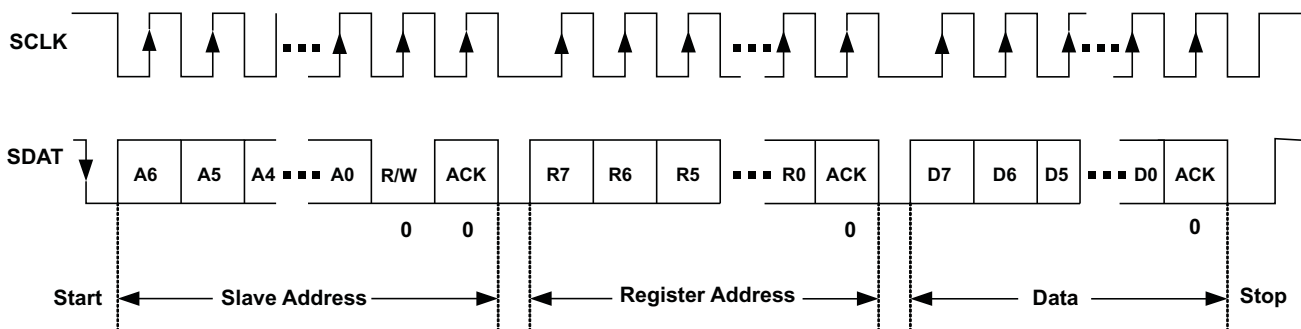

Figure 32. START and STOP Conditions



Note: SLAVE = TPS65023

Figure 33. Serial I/F WRITE to TPS65023x Device

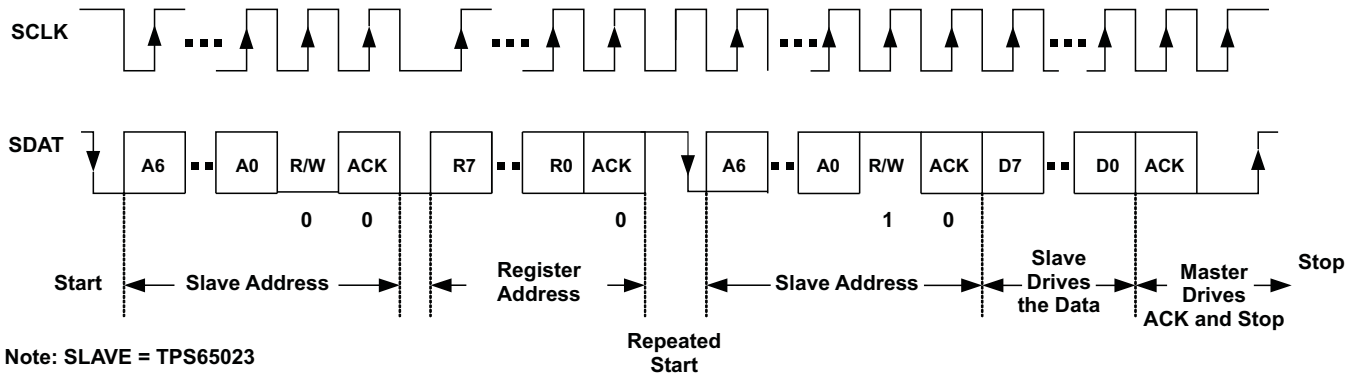

Figure 34. Serial I/F READ from TPS65023x: Protocol A

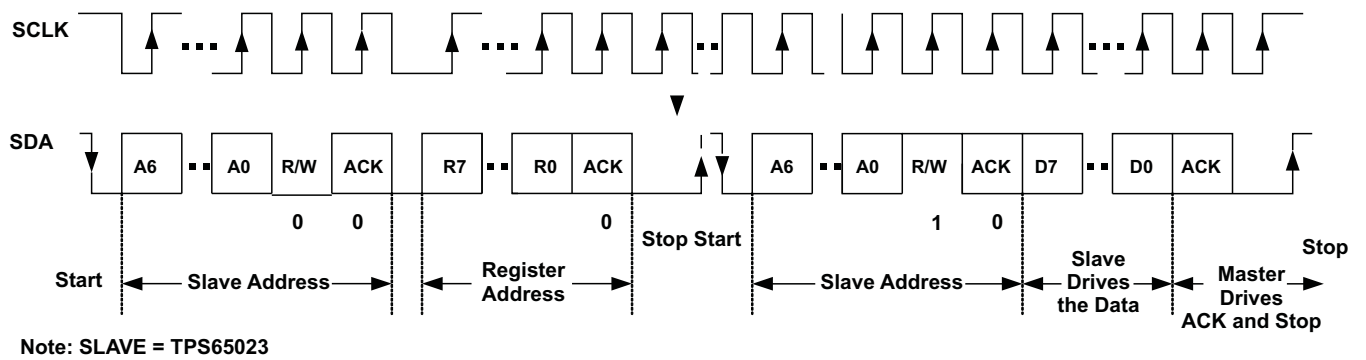

Figure 35. Serial I/F READ from TPS65023x: Protocol B

7.6 Register Maps

7.6.1 VERSION Register Address: 00h (Read Only)

Table 4. VERSION Register

VERSION	B7	B6	B5	B4	B3	B2	B1	B0
Bit name and function	0	0	1	0	0	0	1	1
Read and write	R	R	R	R	R	R	R	R

7.6.2 PGOODZ Register Address: 01h (Read Only)

Table 5. PGOODZ Register

PGOODZ	B7	B6	B5	B4	B3	B2	B1	B0
Bit name and function	PWRFAILZ	LOWBATTZ	PGOODZ VDCDC1	PGOODZ VDCDC2	PGOODZ VDCDC3	PGOODZ LDO2	PGOODZ LDO1	–
Set by signal	PWRFAIL	LOWBATT	PGOODZ VDCDC1	PGOODZ VDCDC2	PGOODZ VDCDC3	PGOODZ LDO2	PGOODZ LDO1	–
Default value loaded	PWRFAILZ	LOWBATTZ	PGOOD VDCDC1	PGOOD VDCDC2	PGOOD VDCDC3	PGOOD LDO2	PGOOD LDO1	–
Read and write	R	R	R	R	R	R	R	R

Bit 7 PWRFAILZ:

0 = indicates that the PWRFAIL_SNS input voltage is above the 1-V threshold.

1 = indicates that the PWRFAIL_SNS input voltage is below the 1-V threshold.

Bit 6 LOWBATTZ:

0 = indicates that the LOWBATT_SNS input voltage is above the 1-V threshold.

1 = indicates that the LOWBATT_SNS input voltage is below the 1-V threshold.

Bit 5 PGOODZ VDCDC1:

0 = indicates that the VDCDC1 converter output voltage is within its nominal range. This bit is zero if the VDCDC1 converter is disabled.

1 = indicates that the VDCDC1 converter output voltage is below its target regulation voltage

Bit 4 PGOODZ VDCDC2:

0 = indicates that the VDCDC2 converter output voltage is within its nominal range. This bit is zero if the VDCDC2 converter is disabled.

1 = indicates that the VDCDC2 converter output voltage is below its target regulation voltage

Bit 3 PGOODZ VDCDC3:

0 = indicates that the VDCDC3 converter output voltage is within its nominal range. This bit is zero if the VDCDC3 converter is disabled and during a DVM controlled output voltage transition

1 = indicates that the VDCDC3 converter output voltage is below its target regulation voltage

Bit 2 PGOODZ LDO2:

0 = indicates that the LDO2 output voltage is within its nominal range. This bit is zero if LDO2 is disabled.

1 = indicates that LDO2 output voltage is below its target regulation voltage

Bit 1 PGOODZ LDO1

0 = indicates that the LDO1 output voltage is within its nominal range. This bit is zero if LDO1 is disabled.

1 = indicates that the LDO1 output voltage is below its target regulation voltage

7.6.3 MASK Register Address: 02h (Read and Write), Default Value: C0h

Table 6. MASK Register

MASK	B7	B6	B5	B4	B3	B2	B1	B0
Bit name and function	MASK PWRFAILZ	MASK LOWBATTZ	MASK VDCDC1	MASK VDCDC2	MASK VDCDC3	MASK LDO2	MASK LDO1	–
Default	1	1	0	0	0	0	0	0
Default value loaded	UVLO	UVLO	UVLO	UVLO	UVLO	UVLO	UVLO	–
Read and write	R/W	R/W	R/W	R/W	R/W	R/W	R/W	–

The MASK register can be used to mask particular fault conditions from appearing at the $\overline{\text{INT}}$ pin. MASK<n> = 1 masks PGOODZ<n>.

7.6.4 REG_CTRL Register Address: 03h (Read and Write), Default Value: FFh

The REG_CTRL register is used to disable or enable the power supplies through the serial interface. The contents of the register are logically AND'ed with the enable pins to determine the state of the supplies. A UVLO condition resets the REG_CTRL to 0xFF, so the state of the supplies defaults to the state of the enable pin. The REG_CTRL bits are automatically reset to default when the corresponding enable pin is low.

Table 7. REG_CTRL Register

REG_CTRL	B7	B6	B5	B4	B3	B2	B1	B0
Bit name and function	–	–	VDCDC1 ENABLE	VDCDC2 ENABLE	VDCDC3 ENABLE	LDO2 ENABLE	LDO1 ENABLE	–
Default	1	1	1	1	1	1	1	1
Set by signal	–	–	DCDC1_ENZ	DCDC2_ENZ	DCDC3_ENZ	LDO_ENZ	LDO_ENZ	–
Default value loaded	–	–	UVLO	UVLO	UVLO	UVLO	UVLO	–
Read and write	–	–	R/W	R/W	R/W	R/W	R/W	–

Bit 5 VDCDC1 ENABLE

DCDC1 Enable. This bit is logically AND'ed with the state of the DCDC1_EN pin to turn on the DCDC1 converter. Reset to 1 by a UVLO condition, the bit can be written to 0 or 1 through the serial interface. The bit is reset to 1 when the pin DCDC1_EN is pulled to GND, allowing DCDC1 to turn on when DCDC1_EN returns high.

Bit 4 VDCDC2 ENABLE

DCDC2 Enable. This bit is logically AND'ed with the state of the DCDC2_EN pin to turn on the DCDC2 converter. Reset to 1 by a UVLO condition, the bit can be written to 0 or 1 through the serial interface. The bit is reset to 1 when the pin DCDC2_EN is pulled to GND, allowing DCDC2 to turn on when DCDC2_EN returns high.

Bit 3 VDCDC3 ENABLE

DCDC3 Enable. This bit is logically AND'ed with the state of the DCDC3_EN pin to turn on the DCDC3 converter. Reset to 1 by a UVLO condition, the bit can be written to 0 or 1 through the serial interface. The bit is reset to 1 when the pin DCDC3_EN is pulled to GND, allowing DCDC3 to turn on when DCDC3_EN returns high.

Bit 2 LDO2 ENABLE

LDO2 Enable. This bit is logically AND'ed with the state of the LDO2_EN pin to turn on LDO2. Reset to 1 by a UVLO condition, the bit can be written to 0 or 1 through the serial interface. The bit is reset to 1 when the pin LDO_EN is pulled to GND, allowing LDO2 to turn on when LDO_EN returns high.

Bit 1 LDO1 ENABLE

LDO1 Enable. This bit is logically AND'ed with the state of the LDO1_EN pin to turn on LDO1. Reset to 1 by a UVLO condition, the bit can be written to 0 or 1 through the serial interface. The bit is reset to 1 when the pin LDO_EN is pulled to GND, allowing LDO1 to turn on when LDO_EN returns high.

7.6.5 CON_CTRL Register Address: 04h (Read and Write), Default Value: B1h
Table 8. CON_CTRL Register

CON_CTRL	B7	B6	B5	B4	B3	B2	B1	B0
Bit name and function	DCDC2 PHASE1	DCDC2 PHASE0	DCDC3 PHASE1	DCDC3 PHASE0	LOW RIPPLE	FPWM DCDC2	FPWM DCDC1	FPWM DCDC3
Default	1	0	1	1	0	0	0	0
Default value loaded	UVLO	UVLO	UVLO	UVLO	UVLO	UVLO	UVLO	UVLO
Read and write	R/W	R/W	R/W	R/W	R/W	R/W	R/W	R/W

The CON_CTRL register is used to force any or all of the converters into forced PWM operation, when low output voltage ripple is vital. It is also used to control the phase shift between the three converters to minimize the input rms current, hence reduce the required input blocking capacitance. The DCDC1 converter is taken as the reference and consequently has a fixed zero phase shift.

Table 9. DCDC2 and DCDC3 Phase Delay

CON_CTRL<7:6>	DCDC2 CONVERTER DELAYED BY	CON_CTRL<5:4>	DCDC3 CONVERTER DELAYED BY
00	zero	00	zero
01	1/4 cycle	01	1/4 cycle
10	1/2 cycle	10	1/2 cycle
11	3/4 cycle	11	3/4 cycle

Bit 3 LOW RIPPLE:

0 = PFM mode operation optimized for high efficiency for all converters

1 = PFM mode operation optimized for low output voltage ripple for all converters

Bit 2 FPWM DCDC2:

0 = DCDC2 converter operates in PWM / PFM mode

1 = DCDC2 converter is forced into fixed frequency PWM mode

Bit 1 FPWM DCDC1:

0 = DCDC1 converter operates in PWM / PFM mode

1 = DCDC1 converter is forced into fixed frequency PWM mode

Bit 0 FPWM DCDC3:

0 = DCDC3 converter operates in PWM / PFM mode

1 = DCDC3 converter is forced into fixed frequency PWM mode

7.6.6 CON_CTRL2 Register Address: 05h (Read and Write), Default Value: 40h
Table 10. CON_CTRL2 Register

CON_CTRL2	B7	B6	B5	B4	B3	B2	B1	B0
Bit name and function	GO	Core adj allowed	–	–	–	DCDC2 discharge	DCDC1 discharge	DCDC3 discharge
Default	0	1	0	0	0	0	0	0

Table 10. CON_CTRL2 Register (continued)

CON_CTRL2	B7	B6	B5	B4	B3	B2	B1	B0
Default value loaded	UVLO + DONE	RESET(1)	–	–	–	UVLO	UVLO	UVLO
Read and write	R/W	R/W	–	–	–	R/W	R/W	R/W

The CON_CTRL2 register can be used to take control the inductive converters.

RESET(1): CON_CTRL2[6] is reset to its default value by one of these events:

- undervoltage lockout (UVLO)
- $\overline{\text{HOT_RESET}}$ pulled low
- $\overline{\text{RESPWRON}}$ active
- VRTC below threshold

Bit 7 GO:

0 = no change in the output voltage for the DCDC1 converter

1 = the output voltage of the DCDC1 converter is changed to the value defined in DEFCORE with the slew rate defined in DEFSLEW. This bit is automatically cleared when the DVM transition is complete. The transition is considered complete in this case when the desired output voltage code has been reached, not when the VDCDC1 output voltage is actually in regulation at the desired voltage.

Bit 6 CORE ADJ Allowed:

0 = the output voltage is set with the I²C register

1 = DEFDCDC1 is either connected to GND or VCC or an external voltage divider. When connected to GND or VCC, VDCDC1 defaults to 1.2 V or 1.6 V respectively at start-up

Bit 2–0 0 = the output capacitor of the associated converter is not actively discharged when the converter is disabled

1 = the output capacitor of the associated converter is actively discharged when the converter is disabled. This decreases the fall time of the output voltage at light load

7.6.7 DEFCORE Register Address: 06h (Read and Write), Default Value: 14h/1Eh

Table 11. DEFCORE Register

DEFCORE	B7	B6	B5	B4	B3	B2	B1	B0
Bit name and function	–	–	–	CORE4	CORE3	CORE2	CORE1	CORE0
Default	0	0	0	1	DEFDCDC1	DEFDCDC1	DEFDCDC1	DEFDCDC1
Default value loaded	–	–	–	RESET(1)	RESET(1)	RESET(1)	RESET(1)	RESET(1)
Read and write	–	–	–	R/W	R/W	R/W	R/W	R/W

RESET(1): DEFCORE is reset to its default value by one of these events:

- undervoltage lockout (UVLO)
- $\overline{\text{HOT_RESET}}$ pulled low
- $\overline{\text{RESPWRON}}$ active
- VRTC below threshold

Table 12. DCDC3 DVS Voltages

CORE4	CORE3	CORE2	CORE1	CORE0	VDCDC1	CORE4	CORE3	CORE2	CORE1	CORE0	VDCDC1
0	0	0	0	0	0.8 V	1	0	0	0	0	1.2 V
0	0	0	0	1	0.825 V	1	0	0	0	1	1.225 V
0	0	0	1	0	0.85 V	1	0	0	1	0	1.25 V
0	0	0	1	1	0.875 V	1	0	0	1	1	1.275 V
0	0	1	0	0	0.9 V	1	0	1	0	0	1.3 V
0	0	1	0	1	0.925 V	1	0	1	0	1	1.325 V
0	0	1	1	0	0.95 V	1	0	1	1	0	1.35 V
0	0	1	1	1	0.975 V	1	0	1	1	1	1.375 V
0	1	0	0	0	1 V	1	1	0	0	0	1.4 V
0	1	0	0	1	1.025 V	1	1	0	0	1	1.425 V
0	1	0	1	0	1.05 V	1	1	0	1	0	1.45 V
0	1	0	1	1	1.075 V	1	1	0	1	1	1.475 V
0	1	1	0	0	1.1 V	1	1	1	0	0	1.5 V
0	1	1	0	1	1.125 V	1	1	1	0	1	1.525 V
0	1	1	1	0	1.15 V	1	1	1	1	0	1.55 V
0	1	1	1	1	1.175 V	1	1	1	1	1	1.6 V

7.6.8 DEFSLEW Register Address: 07h (Read and Write), Default Value: 06h
Table 13. DEFSLEW Register

DEFSLEW	B7	B6	B5	B4	B3	B2	B1	B0
Bit name and function	–	–	–	–	–	SLEW2	SLEW1	SLEW0
Default	–	–	–	–	–	1	1	0
Default value loaded	–	–	–	–	–	UVLO	UVLO	UVLO
Read and write	–	–	–	–	–	R/W	R/W	R/W

Table 14. DCDC3 DVS Slew Rate

SLEW2	SLEW1	SLEW0	VDCDC1 SLEW RATE
0	0	0	0.225 mV/μs
0	0	1	0.45 mV/μs
0	1	0	0.9 mV/μs
0	1	1	1.8 mV/μs
1	0	0	3.6 mV/μs
1	0	1	7.2 mV/μs
1	1	0	14.4 mV/μs
1	1	1	Immediate

7.6.9 LDO_CTRL Register Address: 08h (Read and Write), Default Value: Set with DEFLDO1 and DEFLDO2
Table 15. LDO_CTRL Register

LDO_CTRL	B7	B6	B5	B4	B3	B2	B1	B0
Bit name and function	RSVD	LDO2_2	LDO2_1	LDO2_0	RSVD	LDO1_2	LDO1_1	LDO1_0
Default	–	DEFLDOx	DEFLDOx	DEFLDOx	–	DEFLDOx	DEFLDOx	DEFLDOx
Default value loaded	–	UVLO	UVLO	UVLO	–	UVLO	UVLO	UVLO
Read and write	–	R/W	R/W	R/W	–	R/W	R/W	R/W

The LDO_CTRL registers are used to set the output voltage of LDO1 and LDO2. LDO_CTRL[7] and LDO_CTRL[3] are reserved and must always be written to **0**.

The default voltage is set with DEFLDO1 and DEFLDO2 pins as described in [Table 16](#).

Table 16. LDO2 and LDO3 I2C Voltage Options

LDO2_2	LDO2_1	LDO2_0	LDO2 OUTPUT VOLTAGE		LDO1_2	LDO1_1	LDO1_0	LDO1 OUTPUT VOLTAGE
0	0	0	1.05 V		0	0	0	1 V
0	0	1	1.2 V		0	0	1	1.1 V
0	1	0	1.3 V		0	1	0	1.3 V
0	1	1	1.8 V		0	1	1	1.8 V
1	0	0	2.5 V		1	0	0	2.2 V
1	0	1	2.8 V		1	0	1	2.6 V
1	1	0	3.0 V		1	1	0	2.8 V
1	1	1	3.3 V		1	1	1	3.15 V

8 Application and Implementation

NOTE

Information in the following applications sections is not part of the TI component specification, and TI does not warrant its accuracy or completeness. TI's customers are responsible for determining suitability of components for their purposes. Customers should validate and test their design implementation to confirm system functionality.

8.1 Application Information

8.1.1 Input Voltage Connection

The low power section of the control circuit for the step-down converters DCDC1, DCDC2, and DCDC3 is supplied by the VCC pin while the circuitry with high power such as the power stage is powered from the VINDCDC1, VINDCDC2, and VINDCDC3 pins. For proper operation of the step-down converters, VINDCDC1, VINDCDC2, VINDCDC3, and VCC must be tied to the same voltage rail. Step-down converters that are planned to be not used, still need to be powered from their input pin on the same rails than the other step-down converters and VCC.

LDO1 and LDO2 share a supply voltage pin which can be powered from the V_{CC} rails or from a voltage lower than V_{CC} , for example, the output of one of the step-down converters as long as it is operated within the input voltage range of the LDOs. If both LDOs are not used, the VINLDO pin can be tied to GND.

8.1.2 Unused Regulators

In case a step-down converter is not used, its input supply voltage pin VINDCDCx still needs to be connected to the V_{CC} rail along with supply input of the other step-down converters. TI recommends closing the control loop such that an inductor and output capacitor is added in the same way as it would be when operated normally. If one of the LDOs is not used, its output capacitor must be added as well. If both LDOs are not used, the input supply pin as well as the output pins of the LDOs (VINLDO, VLDO1, VLDO2) must be tied to GND.

8.1.3 Reset Condition of DCDC1

If DEFDCDC1 is connected to ground and DCDC1_EN is pulled high after VINDCDC1 is applied, the output voltage of DCDC1 defaults to 1.225 V instead of 1.2 V (high by 2%). [Figure 36](#) illustrates the problem.

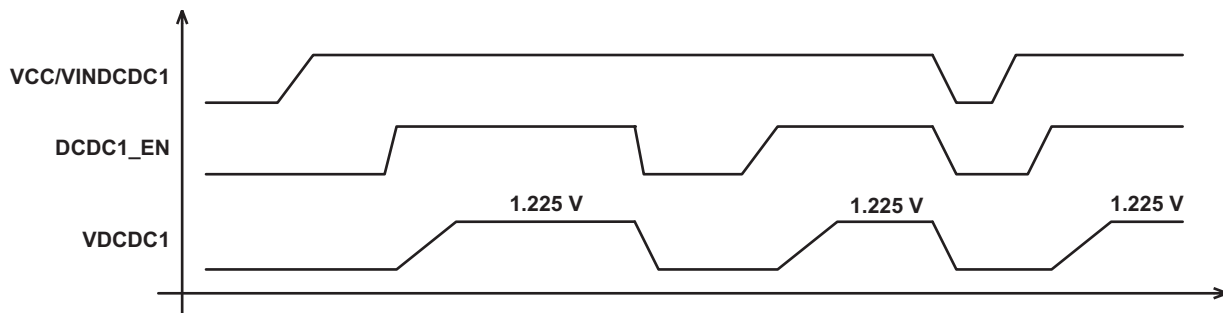

Figure 36. Default DCDC1

Application Information (continued)

One workaround is to tie DCDC1_EN to VINDCDC1 (Figure 37).

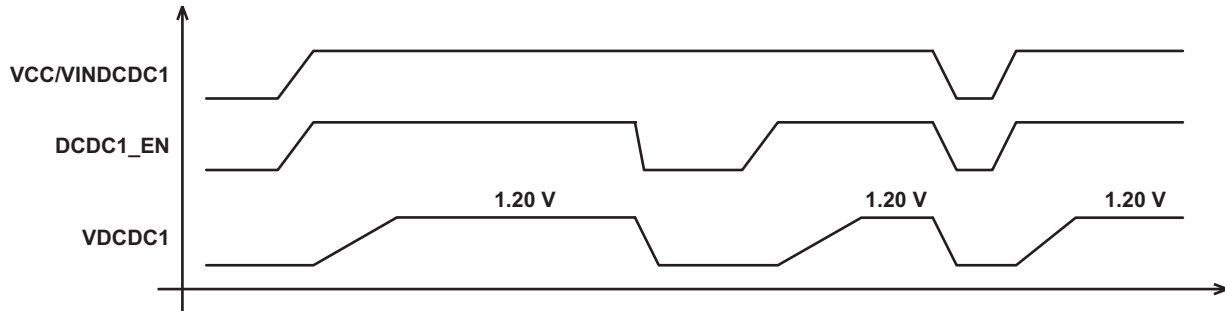

Figure 37. Workaround 1

Another workaround is to write the correct voltage to the DEF_CORE register through I²C. This can be done before or after the converter is enabled. If written before the enable, the only bit changed is DEF_CORE[0]. The voltage is 1.2 V, however, when the enable is pulled high (Figure 38).

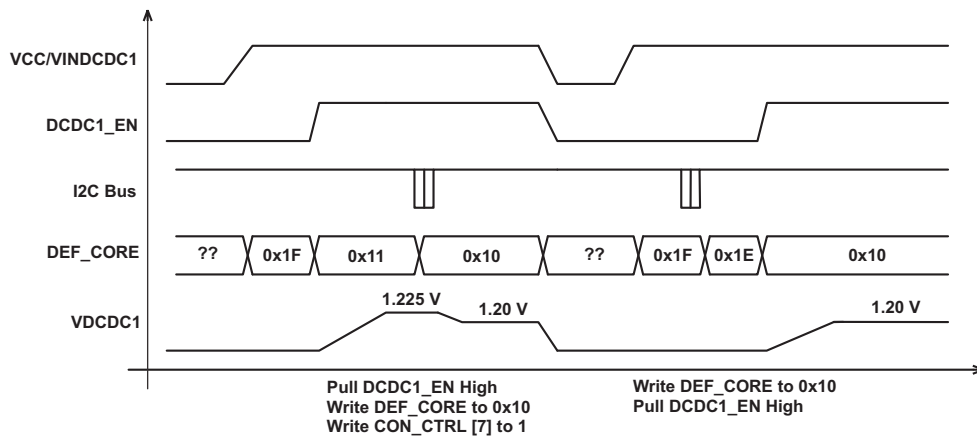

Figure 38. Workaround 2

A third workaround is to generate a $\overline{\text{HOT_RESET}}$ after enabling DCDC1 (Figure 39)

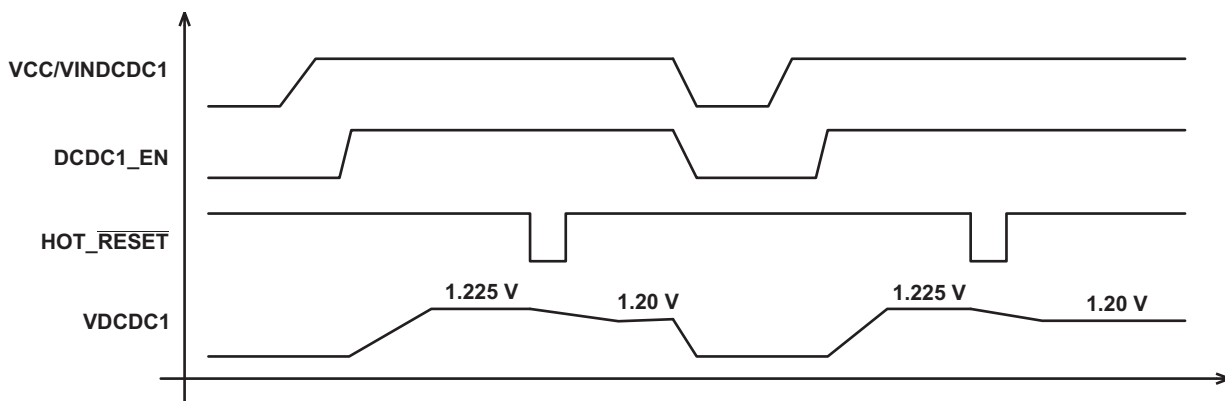

Figure 39. Workaround 3

Application Information (continued)

Table 17. Changes of TPS65023B vs TPS65023

ITEM	DESCRIPTION	Reference	TPS65023	TPS65023B
V _{IH}	High level input voltage for the SDAT pin	<i>Electrical Characteristics</i>	Minimum 1.3 V	Minimum 1.69 V; V _{CC} = 2.5 V to 5.25 V Minimum 1.55 V; V _{CC} = 2.5 V to 4.5 V
V _{IH}	High level input voltage for the SCLK pin		Minimum 1.3 V	Minimum 1.4 V; V _{CC} = 2.5 V to 5.25 V
V _{IL}	Low level input voltage for SCLK and SDAT pin		Maximum 0.4 V	Maximum 0.35 V
t _h (DATA)	Data input hold time	<i>I²C Timing Requirements for TPS65023B</i>	Minimum 300 ns	Minimum 100 ns
t _{su} (DATA)	Data input setup time		Minimum 300 ns	Minimum 100 ns

8.2 Typical Application

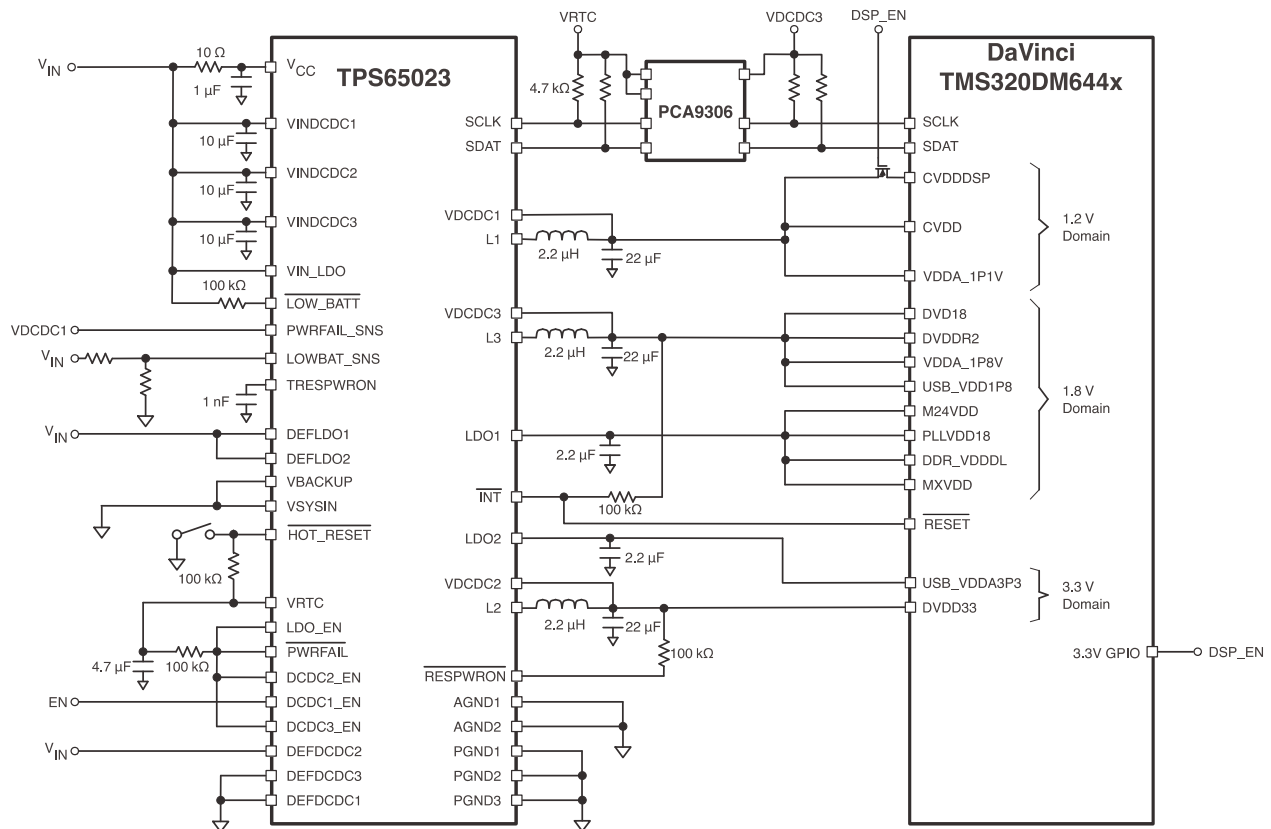

Figure 40. Typical Configuration for the Texas Instruments TMS320DM644x DaVinci™ Processors

8.2.1 Design Requirements

The TPS6502x devices have only a few design requirements. Use the following parameters for the design examples:

- 1- μ F bypass capacitor on VCC, located as close as possible to the VCC pin to ground
- VCC and VINDCDCx must be connected to the same voltage supply with minimal voltage difference.
- Input capacitors must be present on the VINDCDCx and VIN_LDO supplies if used
- Output inductor and capacitors must be used on the outputs of the DC–DC converters if used
- Output capacitors must be used on the outputs of the LDOs if used

Typical Application (continued)

8.2.2 Detailed Design Procedure

8.2.2.1 Inductor Selection for the DC-DC Converters

Each of the converters in the TPS65023x typically use a 2.2- μ H output inductor. Larger or smaller inductor values are used to optimize the performance of the device for specific operation conditions. The selected inductor has to be rated for its DC resistance and saturation current. The DC resistance of the inductance influences directly the efficiency of the converter. Therefore, an inductor with lowest DC resistance must be selected for highest efficiency.

For a fast transient response, a 2.2- μ H inductor in combination with a 22- μ F output capacitor is recommended.

[Equation 8](#) calculates the maximum inductor current under static load conditions. The saturation current of the inductor must be rated higher than the maximum inductor current as calculated with [Equation 8](#). This is needed because during heavy load transient the inductor current rises above the calculated value.

$$\Delta I_L = V_{out} \times \frac{1 - \frac{V_{out}}{V_{in}}}{L \times f} \quad (8)$$

$$I_{Lmax} = I_{outmax} + \frac{\Delta I_L}{2}$$

where

- f = Switching Frequency (2.25 MHz typical)
- L = Inductor Value
- ΔI_L = Peak-to-Peak inductor ripple current
- I_{LMAX} = Maximum Inductor current

The highest inductor current occurs at maximum V_{in} .

Open-core inductors have a soft saturation characteristic, and they can usually handle higher inductor currents versus a comparable shielded inductor.

A conservative approach is to select the inductor current rating just for the maximum switch current of the TPS65023x (2 A for the VDCDC1 and VDCDC2 converters, and 1.5 A for the VDCDC3 converter). The core material from inductor to inductor differs and has an impact on the efficiency especially at high switching frequencies.

See [Table 18](#) and the typical applications for possible inductors.

Table 18. Tested Inductors

DEVICE	INDUCTOR VALUE	TYPE	COMPONENT SUPPLIER
All converters	2.2 μ H	LPS4012-222LMB	Coilcraft
	2.2 μ H	VLCF4020T-2R2N1R7	TDK
For DCDC2 or DCDC3	2.2 μ H	LQH32PN2R2NN0	Murata
For DCDC1	1.5 μ H	LQH32PN1R5NN0	Murata
All converters	2.2 μ H	PST25201B-2R2MS	Cyntec

8.2.2.2 Output Capacitor Selection

The advanced fast response voltage mode control scheme of the inductive converters implemented in the TPS65023x allow the use of small ceramic capacitors with a typical value of 10 μ F for each converter without having large output voltage under and overshoots during heavy load transients. Ceramic capacitors having low ESR values have the lowest output voltage ripple and are recommended. See [Table 19](#) for recommended components.

If ceramic output capacitors are used, the capacitor RMS ripple current rating always meets the application requirements. Just for completeness, the RMS ripple current is calculated in [Equation 10](#).

$$I_{\text{RMSOut}} = V_{\text{out}} \times \frac{1 - \frac{V_{\text{out}}}{V_{\text{in}}}}{L \times f} \times \frac{1}{2 \times \sqrt{3}} \quad (10)$$

At nominal load current, the inductive converters operate in PWM mode. The overall output voltage ripple is the sum of the voltage spike caused by the output capacitor ESR plus the voltage ripple caused by charging and discharging the output capacitor:

$$\Delta V_{\text{out}} = V_{\text{out}} \times \frac{1 - \frac{V_{\text{out}}}{V_{\text{in}}}}{L \times f} \times \left(\frac{1}{8 \times C_{\text{out}} \times f} + \text{ESR} \right)$$

where

- The highest output voltage ripple occurs at the highest input voltage V_{in} (11)

At light load currents, the converters operate in PSM and the output voltage ripple is dependent on the output capacitor value. The output voltage ripple is set by the internal comparator delay and the external capacitor. The typical output voltage ripple is less than 1% of the nominal output voltage.

8.2.2.3 Input Capacitor Selection

Because of the nature of the buck converter having a pulsating input current, a low ESR input capacitor is required for best input voltage filtering and minimizing the interference with other circuits caused by high input voltage spikes. Each DC-DC converter requires a 10- μF ceramic input capacitor on its input pin V_{INDCDCx} . The input capacitor is increased without any limit for better input voltage filtering. The VCC pin is separated from the input for the DC-DC converters. A filter resistor of up to 10R and a 1- μF capacitor is used for decoupling the VCC pin from switching noise. Note that the filter resistor may affect the UVLO threshold since up to 3 mA can flow through this resistor into the VCC pin when all converters are running in PWM mode.

Table 19. Possible Capacitors

CAPACITOR VALUE	CASE SIZE	COMPONENT SUPPLIER	COMMENTS
22 μF	1206	TDK C3216X5R0J226M	Ceramic
22 μF	1206	Taiyo Yuden JMK316BJ226ML	Ceramic
22 μF	0805	TDK C2012X5R0J226MT	Ceramic
22 μF	0805	Taiyo Yuden JMK212BJ226MG	Ceramic
10 μF	0805	Taiyo Yuden JMK212BJ106M	Ceramic
10 μF	0805	TDK C2012X5R0J106M	Ceramic

8.2.2.4 Output Voltage Selection

The DEFDCDC1, DEFDCDC2, and DEFDCDC3 pins are used to set the output voltage for each step-down converter. See [Table 20](#) for the default voltages if the pins are pulled to GND or to VCC. If a different voltage is needed, an external resistor divider can be added to the DEFDCDCx pin as shown in [Figure 41](#).

The output voltage of VDCDC1 is set with the I²C interface. If the voltage is changed from the default, using the DEFDCDC1 register, the output voltage only depends on the register value. Any resistor divider at DEFDCDC1 does not change the voltage set with the register.

Table 20. DCDC1, DCDC2, and DCDC3 Default Voltage Levels

PIN	LEVEL	DEFAULT OUTPUT VOLTAGE
DEFDCDC1	VCC	1.6 V
	GND	1.2 V
DEFDCDC2	VCC	3.3 V
	GND	1.8 V

Table 20. DCDC1, DCDC2, and DCDC3 Default Voltage Levels (continued)

PIN	LEVEL	DEFAULT OUTPUT VOLTAGE
DEFDCDC3	VCC	3.3 V
	GND	1.8 V

Using an external resistor divider at DEFDCDCx:

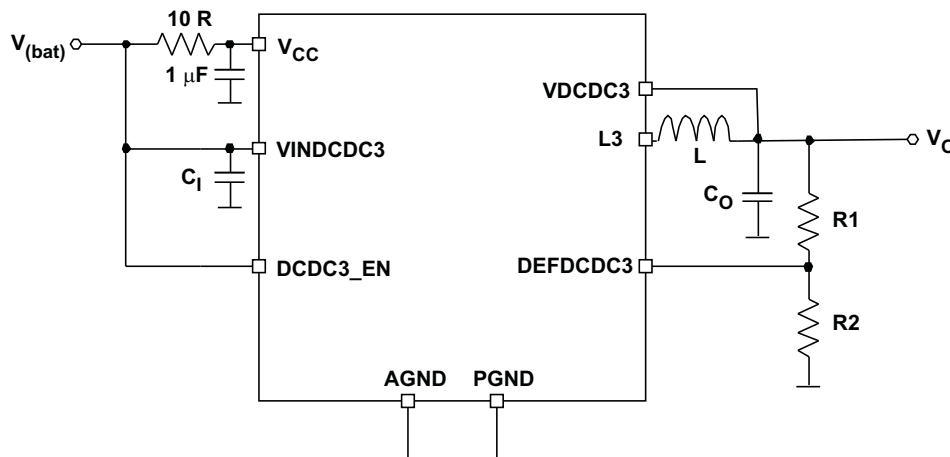
Figure 41. External Resistor Divider

When a resistor divider is connected to DEFDCDCx, the output voltage can be set from 0.6 V up to the input voltage $V_{(bat)}$. The total resistance ($R1 + R2$) of the voltage divider must be kept in the 1-MR range to maintain a high efficiency at light load.

$$V_{(DEFDCDCx)} = 0.6 \text{ V}$$

$$V_{OUT} = V_{DEFDCDCx} \times \frac{R1 + R2}{R2} \quad R1 = R2 \times \left(\frac{V_{OUT}}{V_{DEFDCDCx}} \right) - R2 \quad (12)$$

8.2.2.5 VRTC Output

It is required that a 4.7- μ F (minimum) capacitor be added to the VRTC pin even if the output is not used.

8.2.2.6 LDO1 and LDO2

The LDOs in the TPS65023x are general-purpose LDOs which are stable using ceramics capacitors. The minimum output capacitor required is 2.2 μ F. The LDOs output voltage can be changed to different voltages between 1 V and 3.3 V using the I²C interface. Therefore, they can also be used as general-purpose LDOs in applications powering processors different from DaVinci. The supply voltage for the LDOs needs to be connected to the VINLDO pin, giving the flexibility to connect the lowest voltage available in the system and provides the highest efficiency.

8.2.2.7 TRESPWRON

This is the input to a capacitor that defines the reset delay time after the voltage at VRTC rises above 2.52 V. The timing is generated by charging and discharging the capacitor with a current of 2 μ A between a threshold of 0.25 V and 1 V for 128 cycles. A 1-nF capacitor gives a delay time of 100 ms.

While there is no real upper and lower limit for the capacitor connected to TRESPWRON, TI recommends not leaving signal pins open.

$$t_{(reset)} = 2 \times 128 \times \left(\frac{(1 \text{ V} - 0.25 \text{ V}) \times C_{(reset)}}{2 \mu\text{A}} \right)$$

where

- $t_{(reset)}$ is the reset delay time
 - $C_{(reset)}$ is the capacitor connected to the TRESPWRON pin
- (13)

The minimum and maximum values for the timing parameters called ICONST (2 μ A), TRESPWRON_UPTH (1 V), and TRESPWRON_LOWTH (0.25 V) can be found under [Electrical Characteristics](#).

8.2.2.8 V_{CC} Filter

An RC filter connected at the VCC input is used to keep noise from the internal supply for the bandgap and other analog circuitry. A typical value of 1 Ω and 1 μ F is used to filter the switching spikes, generated by the DC-DC converters. A larger resistor than 10 Ω must not be used because the current into VCC of up to 3 mA causes a voltage drop at the resistor causing the undervoltage lockout circuitry connected at VCC internally to switch off too early.

8.2.3 Application Curves

Graphs were taken using the EVM with the following inductor and output capacitor combinations:

CONVERTER	INDUCTOR	OUTPUT CAPACITOR	OUTPUT CAPACITOR VALUE
VDCDC1	VLCF4020-2R2	C2012X5R0J106M	2 x 10 μ F
VDCDC2	VLCF4020-2R2	C2012X5R0J106M	2 x 10 μ F
VDCDC3	VLF4012AT-2R2M1R5	C2012X5R0J106M	2 x 10 μ F

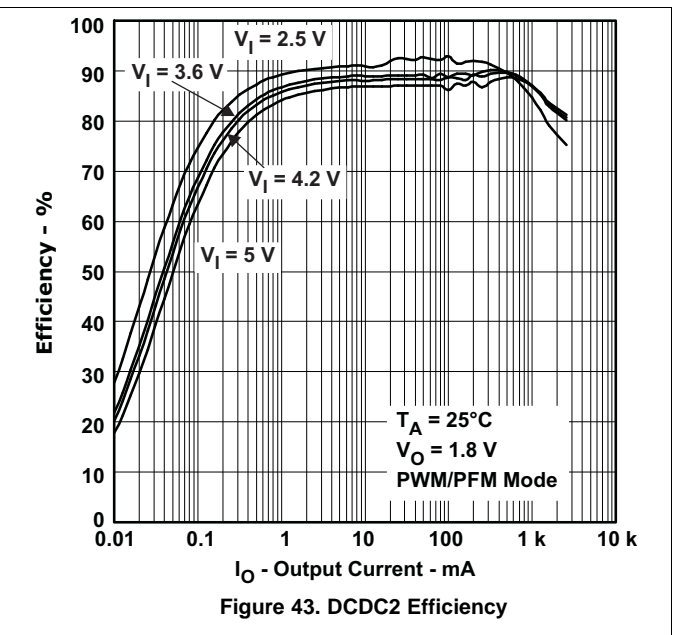
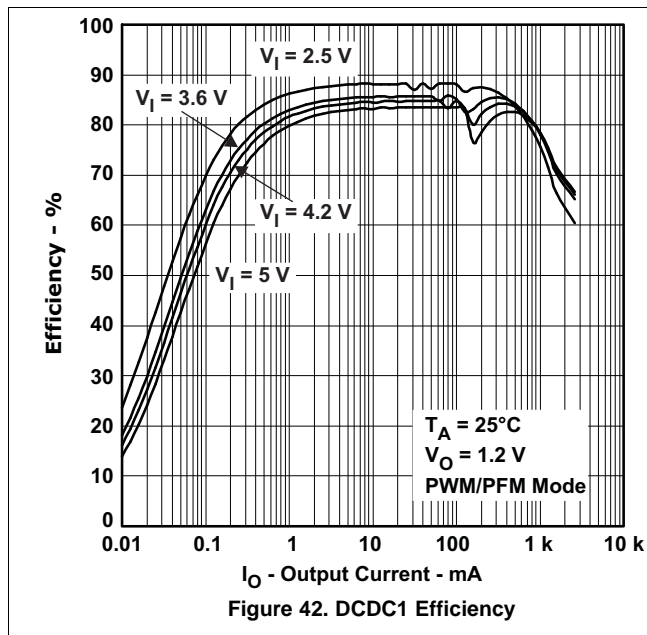

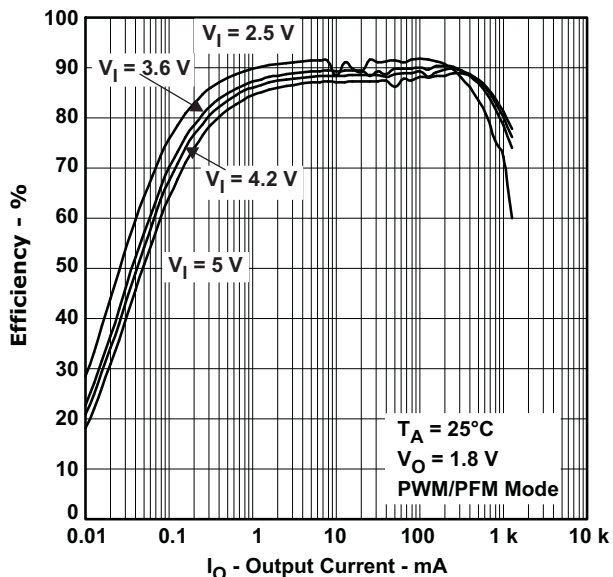

Figure 44. DCDC3 Efficiency

9 Power Supply Recommendations

9.1 Requirements for Supply Voltages Below 3.0 V

For a supply voltage on pins V_{CC}, VINDCDC1, VINDCDC2, and VINDCDC3 below 3.0 V, TI recommends enabling the DCDC1, DCDC2, and DCDC3 converters in sequence. If all 3 step-down converters are enabled at the same time while the supply voltage is close to the internal reset detection threshold, a reset may be generated during power-up. Therefore TI recommends enabling the DC-DC converters in sequence. This can be done by driving one or two of the enable pins with a RC delay or by driving the enable pin by the output voltage of one of the other step-down converters. If a voltage above 3.0 V is applied on pin VBACKUP while V_{CC} and VINDCDCx is below 3.0 V, there is no restriction in the power-up sequencing as VBACKUP will be used to power the internal circuitry.

10 Layout

10.1 Layout Guidelines

As for all switching power supplies, the layout is an important step in the design. Proper function of the device demands careful attention to PCB layout. Take care in board layout to get the specified performance. If the layout is not carefully done, the regulators may show poor line, load regulation, or both, along with stability issues and EMI problems. It is critical to provide a low impedance ground path. Therefore, use wide and short traces for the main current paths. The input capacitors must be placed as close as possible to the IC pins as well as the inductor and output capacitor.

For TPS65023x, connect the PGND pins of the device to the thermal pad land of the PCB and connect the analog ground connections (AGND) to the PGND at the thermal pad. It is essential to provide a good thermal and electrical connection of all GND pins using multiple vias to the GND-plane. Keep the common path to the AGND pins, which returns the small signal components, and the high current of the output capacitors as short as possible to avoid ground noise. The VDCDCx line must be connected right to the output capacitor and routed away from noisy components and traces (for example, the L1, L2, and L3 traces).

10.2 Layout Example

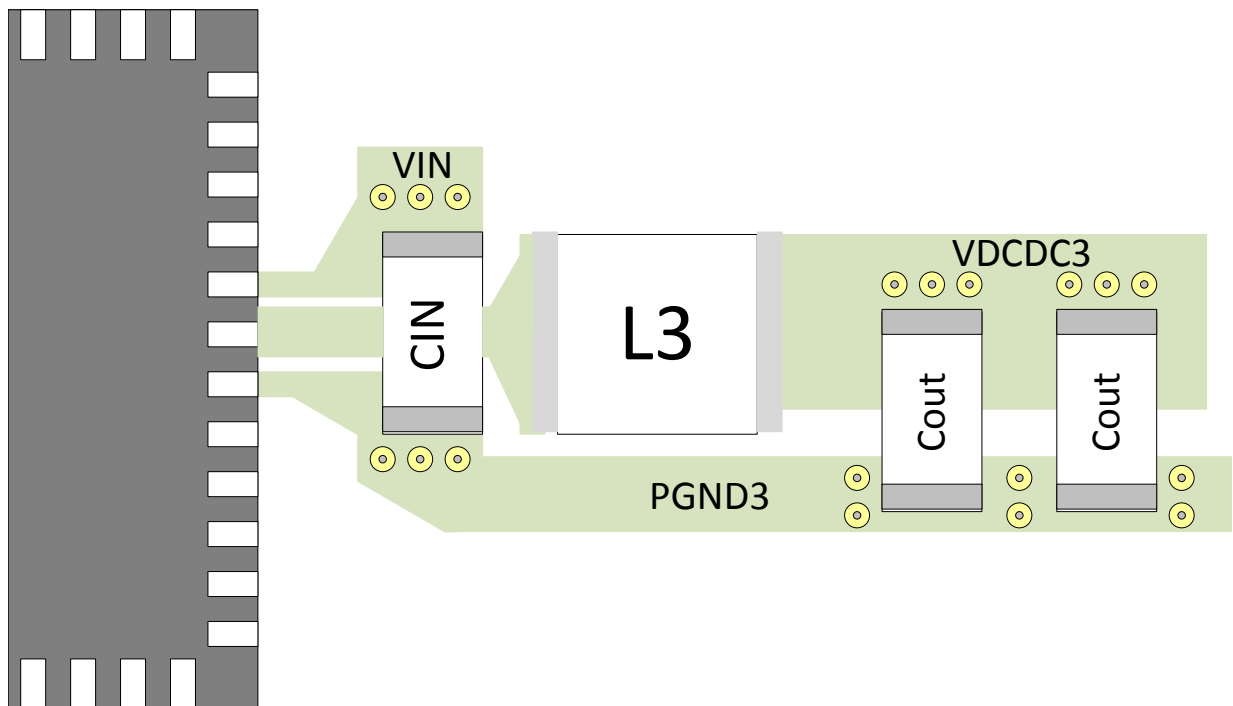

Figure 45. Layout Example of a DC–DC Converter

11 器件和文档支持

11.1 器件支持

11.1.1 第三方产品免责声明

TI 发布的与第三方产品或服务有关的信息，不能构成与此类产品或服务或保修的适用性有关的认可，不能构成此类产品或服务单独或与任何 TI 产品或服务一起的表示或认可。

11.1.2 开发支持

有关开发支持，请参阅：

- 采用 [TPS65023](#) 的 [Altera Cyclone IV FPGA](#) 电源参考设计
- 采用 [TPS65023](#) 的 [Altera Cyclone III FPGA](#) 电源参考设计
- 适用于 [Xilinx Artix®-7](#)、[Spartan®-7](#) 和 [Zynq®-7000 FPGA](#) 的集成电源参考设计
- 适用于 [Xilinx Zynq® UltraScale+™ ZU2CG-ZU5EV MPSoC](#) 的集成电源参考设计

11.2 文档支持

11.2.1 相关文档

如需相关文档，请参阅：

- 德州仪器 (TI), [《使用 TPS65023 的 DaVinci™ 定序》应用报告](#)
- 德州仪器 (TI), [《借助适用于处理器应用的电源管理 IC \(PMIC\) 改进设计应用报告](#)
- 德州仪器 (TI), [《优化比较器输入端的电阻分压器》应用报告](#)
- 德州仪器 (TI), [《使用 TPS65023-Q1 优化 OMAP3630 引导顺序》应用报告](#)
- 德州仪器 (TI), [《采用 TPS65023 并适用 NXP i.MX 6 的电源设计》应用报告](#)
- 德州仪器 (TI), [《采用 TPS65023 并适用 NXP i.MX 7 的电源设计》应用报告](#)
- 德州仪器 (TI), [《采用 TPS65021 且适用于 Freescale™ i.MX35 的电源参考设计》应用报告](#)
- 德州仪器 (TI), [《使用 TPS65023 为 OMAP™3 供电：设计指南》应用报告](#)
- 德州仪器 (TI), [《按钮电路》应用报告](#)
- 德州仪器 (TI), [TPS65023x 检查清单](#)
- 德州仪器 (TI), [《TPS65023EVM 用户指南》](#)
- 德州仪器 (TI), [《TPS65023B/TPS650231EVM 用户指南》](#)

11.3 相关链接

下表列出了快速访问链接。类别包括技术文档、支持与社区资源、工具和软件，以及申请样片或购买产品的快速链接。

表 21. 相关链接

器件	产品文件夹	样片与购买	技术文档	工具与软件	支持和社区
TPS65023	请单击此处	请单击此处	请单击此处	请单击此处	请单击此处
TPS65023B	请单击此处	请单击此处	请单击此处	请单击此处	请单击此处

11.4 社区资源

下列链接提供到 TI 社区资源的连接。链接的内容由各个分销商“按照原样”提供。这些内容并不构成 TI 技术规范，并且不一定反映 TI 的观点；请参阅 TI 的 [《使用条款》](#)。

TI E2E™ 在线社区 [TI 的工程师对工程师 \(E2E\) 社区](#)。此社区的创建目的在于促进工程师之间的协作。在 e2e.ti.com 中，您可以咨询问题、分享知识、拓展思路并与同行工程师一道帮助解决问题。

设计支持 [TI 参考设计支持](#) 可帮助您快速查找有帮助的 E2E 论坛、设计支持工具以及技术支持的联系信息。

11.5 商标

DaVinci, OMAP, E2E are trademarks of Texas Instruments.

11.5 商标 (接下页)

Freescape is a trademark of Motorola, Inc.
I²C is a trademark of NXP Semiconductors.
UltraScale+ is a trademark of Xilinx Inc.
Artix, Spartan, Zynq are registered trademarks of Xilinx Inc.
All other trademarks are the property of their respective owners.

11.6 静电放电警告



ESD 可能会损坏该集成电路。德州仪器 (TI) 建议通过适当的预防措施处理所有集成电路。如果不遵守正确的处理措施和安装程序，可能会损坏集成电路。

ESD 的损坏小至导致微小的性能降级，大至整个器件故障。精密的集成电路可能更容易受到损坏，这是因为非常细微的参数更改都可能会导致器件与其发布的规格不相符。

11.7 术语表

SLYZ022 — TI 术语表。

这份术语表列出并解释术语、缩写和定义。

12 机械、封装和可订购信息

以下页面包含机械、封装和可订购信息。这些信息是指定器件的最新可用数据。数据如有变更，恕不另行通知，且不会对此文档进行修订。如需获取此数据表的浏览器版本，请查阅左侧的导航栏。

PACKAGING INFORMATION

Orderable Device	Status (1)	Package Type	Package Drawing	Pins	Package Qty	Eco Plan (2)	Lead finish/ Ball material (6)	MSL Peak Temp (3)	Op Temp (°C)	Device Marking (4/5)	Samples
TPS65023BRSBR	ACTIVE	WQFN	RSB	40	3000	RoHS & Green	NIPDAU	Level-2-260C-1 YEAR	-40 to 85	TPS 65023B	Samples
TPS65023BRGBT	ACTIVE	WQFN	RSB	40	250	RoHS & Green	NIPDAU	Level-2-260C-1 YEAR	-40 to 85	TPS 65023B	Samples
TPS65023RSBR	ACTIVE	WQFN	RSB	40	3000	RoHS & Green	NIPDAU	Level-2-260C-1 YEAR	-40 to 85	TPS 65023	Samples
TPS65023RSBRG4	ACTIVE	WQFN	RSB	40	3000	RoHS & Green	NIPDAU	Level-2-260C-1 YEAR	-40 to 85	TPS 65023	Samples
TPS65023RSBT	ACTIVE	WQFN	RSB	40	250	RoHS & Green	NIPDAU	Level-2-260C-1 YEAR	-40 to 85	TPS 65023	Samples
TPS65023RSBTG4	ACTIVE	WQFN	RSB	40	250	RoHS & Green	NIPDAU	Level-2-260C-1 YEAR	-40 to 85	TPS 65023	Samples

(1) The marketing status values are defined as follows:

ACTIVE: Product device recommended for new designs.

LIFEBUY: TI has announced that the device will be discontinued, and a lifetime-buy period is in effect.

NRND: Not recommended for new designs. Device is in production to support existing customers, but TI does not recommend using this part in a new design.

PREVIEW: Device has been announced but is not in production. Samples may or may not be available.

OBSELETE: TI has discontinued the production of the device.

(2) **RoHS:** TI defines "RoHS" to mean semiconductor products that are compliant with the current EU RoHS requirements for all 10 RoHS substances, including the requirement that RoHS substance do not exceed 0.1% by weight in homogeneous materials. Where designed to be soldered at high temperatures, "RoHS" products are suitable for use in specified lead-free processes. TI may reference these types of products as "Pb-Free".

RoHS Exempt: TI defines "RoHS Exempt" to mean products that contain lead but are compliant with EU RoHS pursuant to a specific EU RoHS exemption.

Green: TI defines "Green" to mean the content of Chlorine (Cl) and Bromine (Br) based flame retardants meet JS709B low halogen requirements of <=1000ppm threshold. Antimony trioxide based flame retardants must also meet the <=1000ppm threshold requirement.

(3) MSL, Peak Temp. - The Moisture Sensitivity Level rating according to the JEDEC industry standard classifications, and peak solder temperature.

(4) There may be additional marking, which relates to the logo, the lot trace code information, or the environmental category on the device.

(5) Multiple Device Markings will be inside parentheses. Only one Device Marking contained in parentheses and separated by a "-" will appear on a device. If a line is indented then it is a continuation of the previous line and the two combined represent the entire Device Marking for that device.

⁽⁶⁾ Lead finish/Ball material - Orderable Devices may have multiple material finish options. Finish options are separated by a vertical ruled line. Lead finish/Ball material values may wrap to two lines if the finish value exceeds the maximum column width.

Important Information and Disclaimer:The information provided on this page represents TI's knowledge and belief as of the date that it is provided. TI bases its knowledge and belief on information provided by third parties, and makes no representation or warranty as to the accuracy of such information. Efforts are underway to better integrate information from third parties. TI has taken and continues to take reasonable steps to provide representative and accurate information but may not have conducted destructive testing or chemical analysis on incoming materials and chemicals. TI and TI suppliers consider certain information to be proprietary, and thus CAS numbers and other limited information may not be available for release.

In no event shall TI's liability arising out of such information exceed the total purchase price of the TI part(s) at issue in this document sold by TI to Customer on an annual basis.

TAPE AND REEL INFORMATION

QUADRANT ASSIGNMENTS FOR PIN 1 ORIENTATION IN TAPE

*All dimensions are nominal

Device	Package Type	Package Drawing	Pins	SPQ	Reel Diameter (mm)	Reel Width W1 (mm)	A0 (mm)	B0 (mm)	K0 (mm)	P1 (mm)	W (mm)	Pin1 Quadrant
TPS65023BRSBR	WQFN	RSB	40	3000	330.0	12.4	5.3	5.3	1.1	8.0	12.0	Q2
TPS65023BRSBT	WQFN	RSB	40	250	180.0	12.4	5.3	5.3	1.1	8.0	12.0	Q2
TPS65023RSBR	WQFN	RSB	40	3000	330.0	12.4	5.3	5.3	1.1	8.0	12.0	Q2
TPS65023RSBT	WQFN	RSB	40	250	180.0	12.4	5.3	5.3	1.1	8.0	12.0	Q2

TAPE AND REEL BOX DIMENSIONS

*All dimensions are nominal

Device	Package Type	Package Drawing	Pins	SPQ	Length (mm)	Width (mm)	Height (mm)
TPS65023BRSBR	WQFN	RSB	40	3000	346.0	346.0	33.0
TPS65023BRSBT	WQFN	RSB	40	250	210.0	185.0	35.0
TPS65023RSBR	WQFN	RSB	40	3000	346.0	346.0	33.0
TPS65023RSBT	WQFN	RSB	40	250	210.0	185.0	35.0

GENERIC PACKAGE VIEW

RSB 40

WQFN - 0.8 mm max height

5 x 5 mm, 0.4 mm pitch

PLASTIC QUAD FLATPACK - NO LEAD

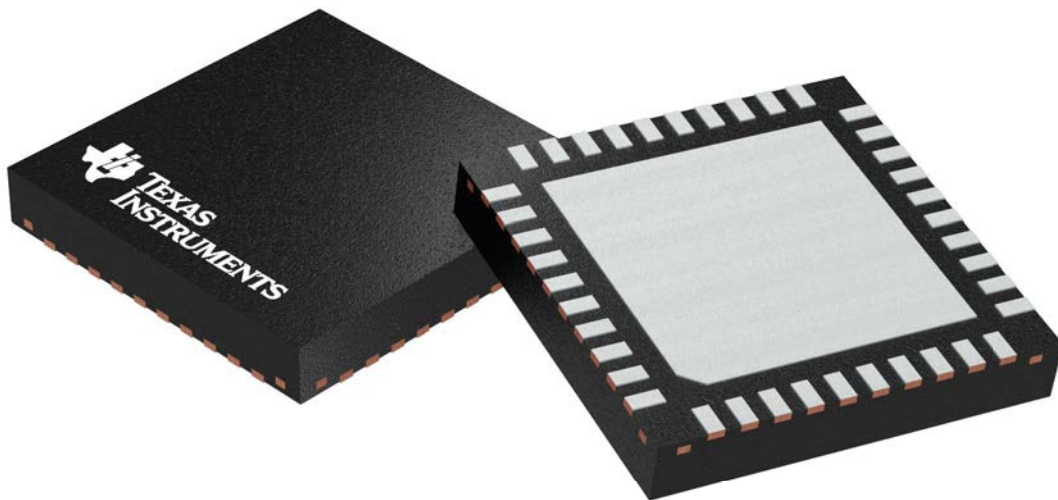

Images above are just a representation of the package family, actual package may vary.
Refer to the product data sheet for package details.

4207182/D

RSB0040B

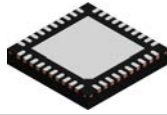

PACKAGE OUTLINE

WQFN - 0.8 mm max height

PLASTIC QUAD FLATPACK - NO LEAD

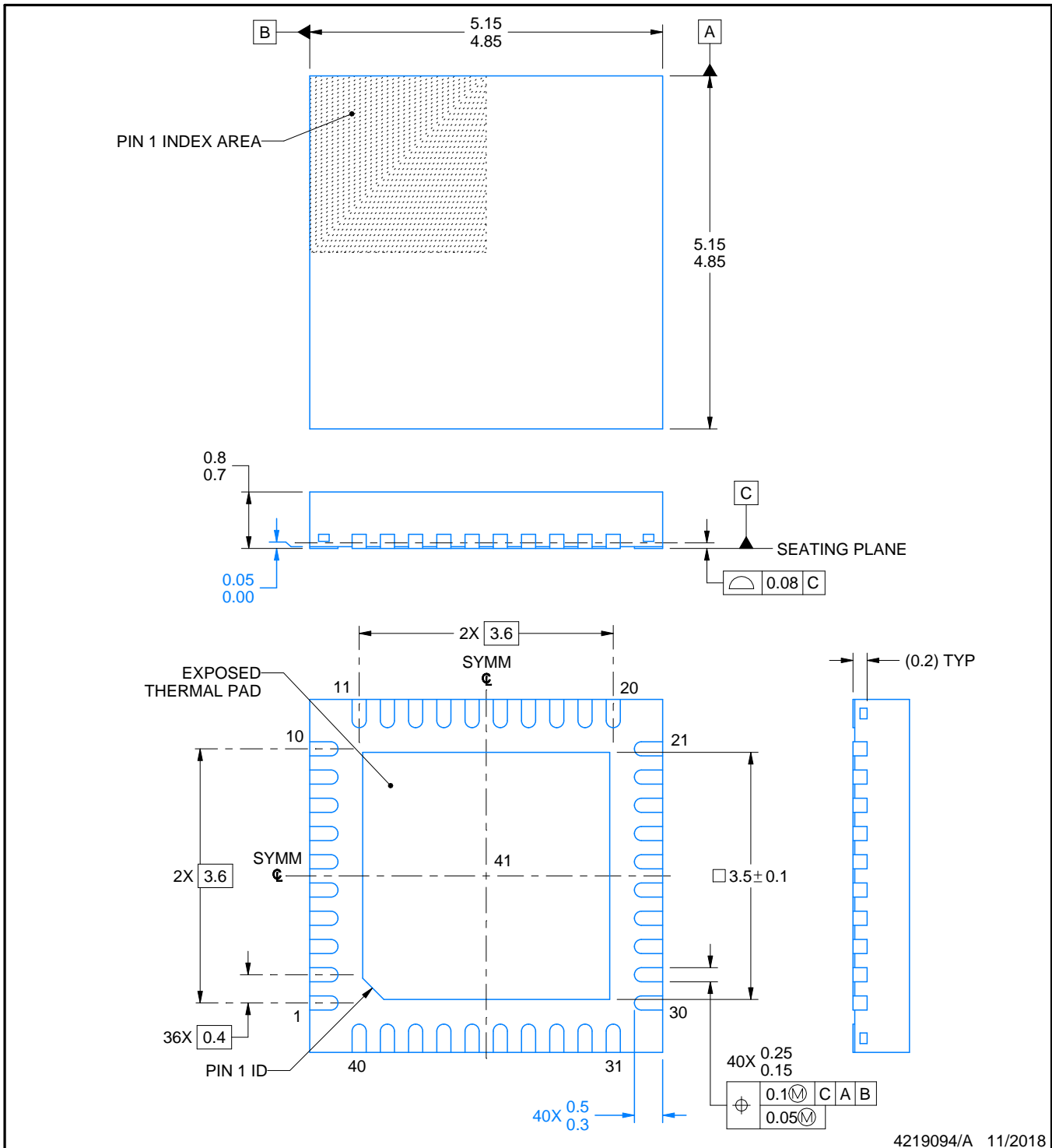

4219094/A 11/2018

NOTES:

1. All linear dimensions are in millimeters. Any dimensions in parenthesis are for reference only. Dimensioning and tolerancing per ASME Y14.5M.
2. This drawing is subject to change without notice.
3. The package thermal pad must be soldered to the printed circuit board for thermal and mechanical performance.

EXAMPLE BOARD LAYOUT

RSB0040B

WQFN - 0.8 mm max height

PLASTIC QUAD FLATPACK - NO LEAD

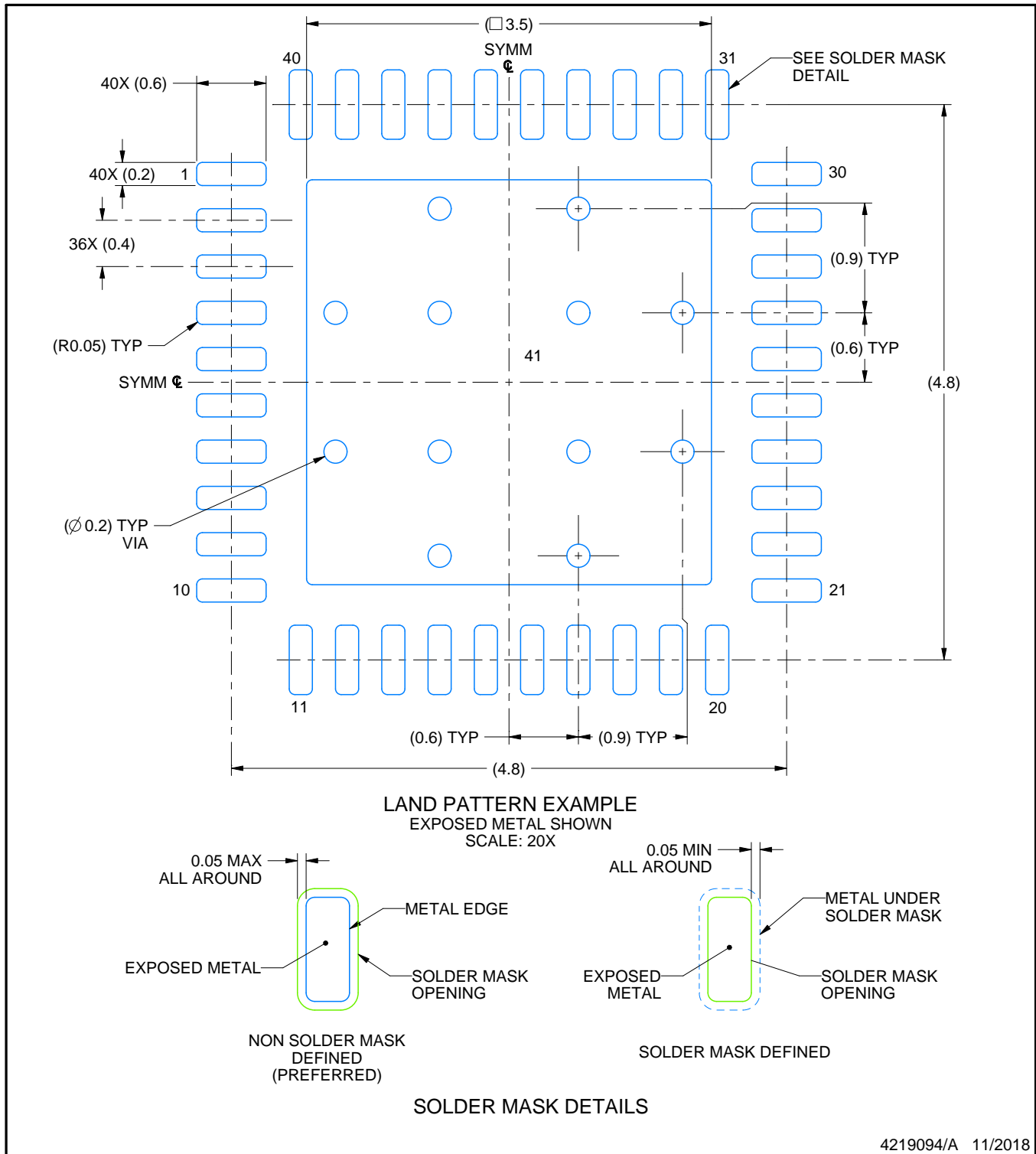

4219094/A 11/2018

NOTES: (continued)

4. This package is designed to be soldered to a thermal pad on the board. For more information, see Texas Instruments literature number SLUA271 (www.ti.com/lit/slua271).
5. Vias are optional depending on application, refer to device data sheet. If any vias are implemented, refer to their locations shown on this view. It is recommended that vias under paste be filled, plugged or tented.

EXAMPLE STENCIL DESIGN

RSB0040B

WQFN - 0.8 mm max height

PLASTIC QUAD FLATPACK - NO LEAD

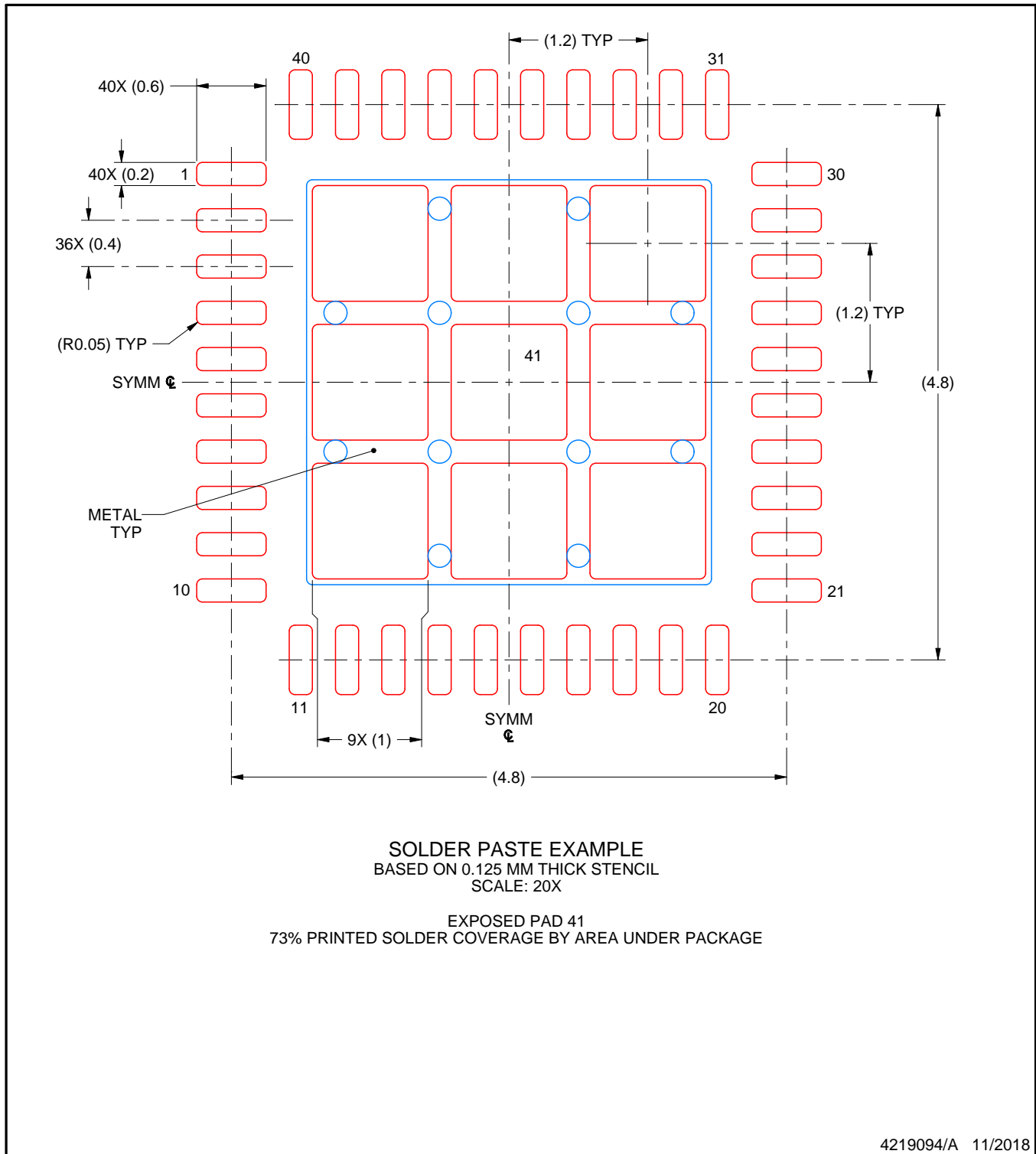

NOTES: (continued)

6. Laser cutting apertures with trapezoidal walls and rounded corners may offer better paste release. IPC-7525 may have alternate design recommendations.

RSB (S-PWQFN-N40)

PLASTIC QUAD FLATPACK NO-LEAD

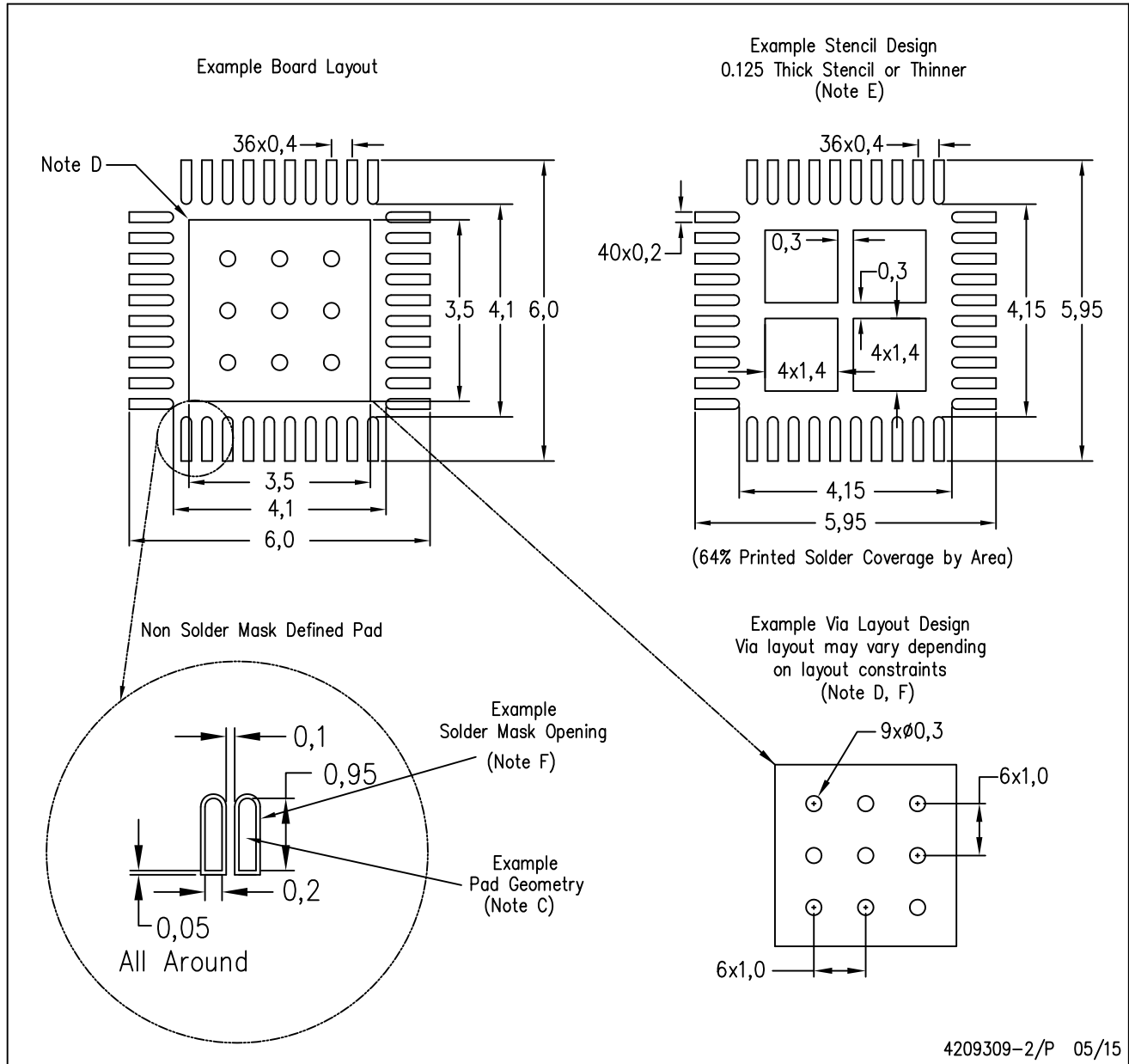

- NOTES:
- A. All linear dimensions are in millimeters.
 - B. This drawing is subject to change without notice.
 - C. Publication IPC-7351 is recommended for alternate designs.
 - D. This package is designed to be soldered to a thermal pad on the board. Refer to Application Note, Quad Flat-Pack Packages, Texas Instruments Literature No. SLUA271, and also the Product Data Sheets for specific thermal information, via requirements, and recommended board layout. These documents are available at www.ti.com <<http://www.ti.com>>.
 - E. Laser cutting apertures with trapezoidal walls and also rounding corners will offer better paste release. Customers should contact their board assembly site for stencil design recommendations. Refer to IPC 7525 for stencil design considerations.
 - F. Customers should contact their board fabrication site for recommended solder mask tolerances and via tenting recommendations for vias placed in the thermal pad.

重要声明和免责声明

TI“按原样”提供技术和可靠性数据（包括数据表）、设计资源（包括参考设计）、应用或其他设计建议、网络工具、安全信息和其他资源，不保证没有瑕疵且不做任何明示或暗示的担保，包括但不限于对适销性、某特定用途方面的适用性或不侵犯任何第三方知识产权的暗示担保。

这些资源可供使用 TI 产品进行设计的熟练开发人员使用。您将自行承担以下全部责任：(1) 针对您的应用选择合适的 TI 产品，(2) 设计、验证并测试您的应用，(3) 确保您的应用满足相应标准以及任何其他功能安全、信息安全、监管或其他要求。

这些资源如有变更，恕不另行通知。TI 授权您仅可将这些资源用于研发本资源所述的 TI 产品的应用。严禁对这些资源进行其他复制或展示。您无权使用任何其他 TI 知识产权或任何第三方知识产权。您应全额赔偿因在这些资源的使用中对 TI 及其代表造成的任何索赔、损害、成本、损失和债务，TI 对此概不负责。

TI 提供的产品受 [TI 的销售条款](#) 或 [ti.com](#) 上其他适用条款/TI 产品随附的其他适用条款的约束。TI 提供这些资源并不会扩展或以其他方式更改 TI 针对 TI 产品发布的适用的担保或担保免责声明。

TI 反对并拒绝您可能提出的任何其他或不同的条款。

邮寄地址：Texas Instruments, Post Office Box 655303, Dallas, Texas 75265

Copyright © 2023，德州仪器 (TI) 公司